

Thermoflo

GWC

Series 2

Factory-Packaged
4 Sizes
70,000 to 175,000 Btuh Input
Natural or Propane Gas



Gas-Fired Condensing Cast Iron Boiler



- ❑ AFUE's above 91%
- ❑ Sealed combustion or direct exhaust venting
- ❑ PVC, polypropylene, or stainless steel venting
- ❑ Multiple pass heat exchanger
- ❑ Cast iron primary heat exchanger
- ❑ Stainless steel condensing secondary heat exchanger
- ❑ Control module with indicator lights
- ❑ Inferred heat program providing automatic adjustment of boiler water temperature to match demand
- ❑ Hot surface ignition system
- ❑ Insulated heavy-gauge steel jacket

MADE IN THE
USA



Thermoflo[®]

RATINGS

Model	Input MBH	AHRI Certified Ratings			Vent Diameter Inches (3)	Boiler Water Content Gal.
		Heating Capacity MBH (1)	Net Water Rating MBH (2)	AFUE % (1)		
GWC-070	70	65	57	91.9	3	3.8
GWC-105	105	97	84	91.2	3	4.7
GWC-140	140	130	113	91.4	3	6.0
GWC-175	175	161	140	91.0	3	6.9

Notes:

- (1) Based on standard test procedures prescribed by the United States Department of Energy.
- (2) Net AHRI ratings are based on net installed radiation of sufficient quantity for the requirements of the building and nothing needs to be added for normal piping and pick-up. Ratings are based on a piping and pick-up allowance of 1.15. An additional allowance should be made for unusual piping and pick-up loads.
- (3) GWC boilers must be vented directly to the outside.

DIMENSIONS

Model	Length Inches L	Supply Tapping In.	Return Tapping In.	Gas Connection Size Inches	Minimum Recommended Pipe Size In.	Approx. Shipping Weight (Lbs)
GWC-070	30 3/4	1	1	1/2	1	313
GWC-105	30 3/4	1	1	1/2	1	353
GWC-140	37 3/4	1	1	1/2	1 1/4	423
GWC-175	37 3/4	1	1	1/2	1 1/4	464

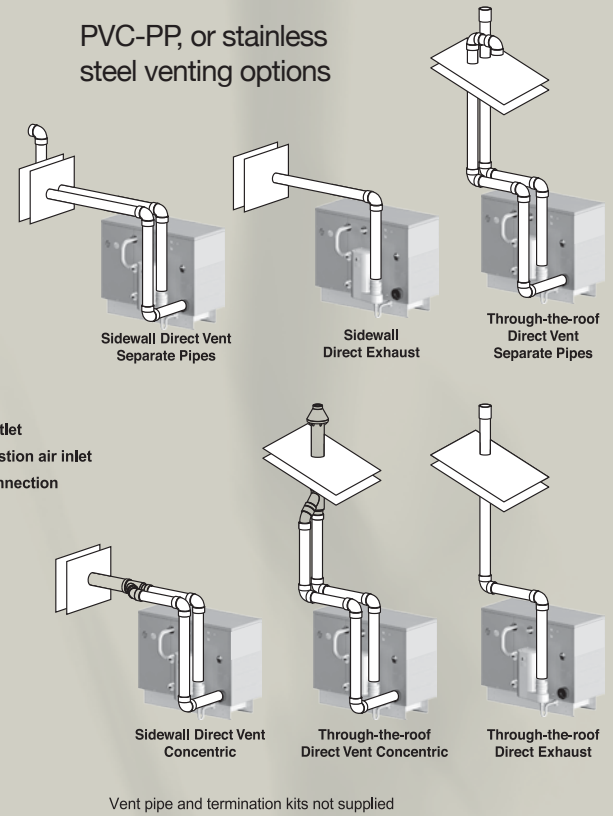
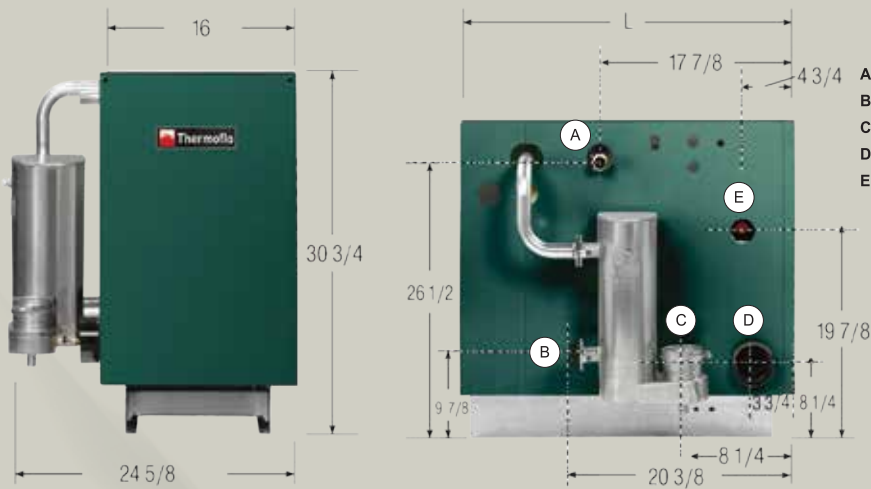

EQUIPMENT

- Factory tested
 - Cast iron sections with built-in air separator
 - Stainless steel secondary heat exchanger with air separator
 - Blower assembly with observation port.
 - Electrical junction box
 - 30 PSI ASME relief valve
 - Hot surface ignition system
 - System circulator*
 - Built-in-bypass circulator system with sensor for temperature control*
 - Negative regulation gas valve
 - Gas/air orifice plate for natural gas (separate plate provided with unit for conversion to propane)
- OPTIONAL:**
- Concentric vent kit
 - High altitude kit
 - Condensation neutralizer kit
- *Circulator supplied with boiler cannot be removed and cannot be used as a zone circulator in multiple zone systems.



8201 West Calumet Road · Milwaukee, WI 53223
www.williamson-thermoflo.com

Form No. T-001 (08/17)



In the interest of continual improvement in product and performance, Thermoflo reserves the right to change specifications without notice.