

Thermoflo

PLB 210 Series 2

Ratings

168,000-210,000 Btuh input

1.20 GPH #2 Fuel Oil



High Input Packaged Low-Boy Oil Furnace

□ Heat exchanger

- Rear flue
- Stainless steel primary heat exchanger
- Tube style aluminized steel secondary heat exchanger with removable baffles
- Large rear access clean out secured with studs and nuts
- Spring-loaded observation port with test plug

□ Blower

- PLB-210 - Multi-speed direct drive (115VAC)

□ Cabinet

- Appliance finish powder coat paint
- Rugged heavy gauge construction
- Foil-faced insulation for hand-cool surface

□ Burner and controls

- Factory-wired
- PSC motor
- Solid state ignitor



Thermoflo®

RATINGS

Model	Input	Output	Firing rate	Installed Nozzle	AFUE	Blower size	Blower motor hp	Blower pulley	Motor pulley	Belt Size (inches)	Maximum cooling capacity	Ship wt.	Blower CFM	
	(Btuh)	(Btuh)	(GPH)								(tons)	(pounds)	@ 0.25" WC	@ 0.50" WC
Direct-drive units														
PLB-210	168,000	138,000	1.20		84.0	GT12-10	3/4	-	-	-	5	250	1950	1900
	189,000	155,000	1.35		83.5	GT12-10	3/4	-	-	-	5	250	2050	1900
	210,000	171,000	1.50	x	83.1	GT12-10	3/4	-	-	-	5	250	2050	nr

NOTE: Filter sizes required are: PLB-210 - (2) 16" x 20" • nr = not recommended

DIMENSIONS

ALL DIMENSIONS IN INCHES

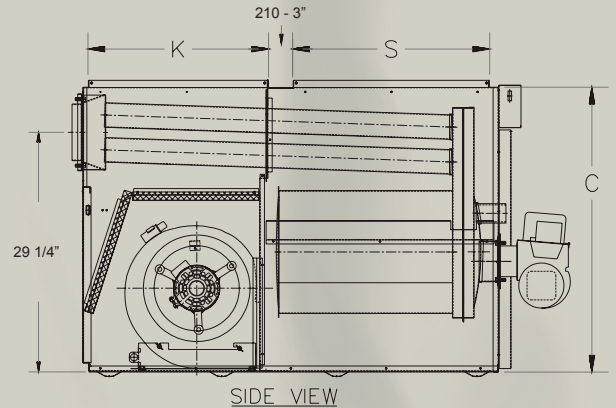
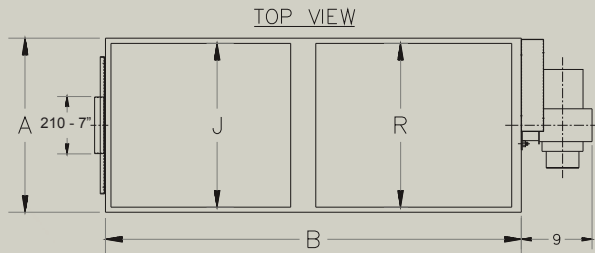
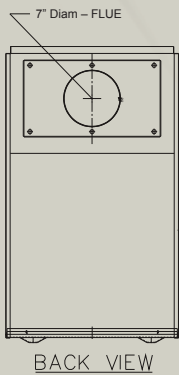

Model	Furnace casing			Warm air supply		Return air		Flue pipe diam.
	Width A	Depth B	Height C	Width R	Depth S	Width J	Depth K	
PLB-210	21-1/4	50-3/4	34-3/4	20	24	20	22	7

Notes:
PLB furnaces are approved for 1" clearance to combustible construction. Refer to installation manual and local codes for details and proper instruction.

EQUIPMENT

- Factory-assembled
- Heat exchanger pressure tested to assure leak-tight construction
- Heavy 14-gauge 430 stainless steel primary heat exchanger
- Aluminized steel secondary heat exchanger with flue collectors
- Rugged 20-gauge cabinet with powder coated finish
- Limit control
- On/Off fan switch
- Barometric damper provided
- High-efficiency flame retention burner (Beckett, Carlin, Riello)
- Optional two-state fuel unit

WARRANTY

- | | |
|---|---|
| <p>Residential Use:</p> <ul style="list-style-type: none"> • 20-year residential use heat exchanger limited warranty • 5-year residential use limited parts warranty | <p>Commercial Use:</p> <ul style="list-style-type: none"> • 5-year commercial use heat exchanger limited warranty • 1-year commercial use limited parts warranty |
|---|---|



Thermoflo®

N93 W14635 Whittaker Way, Menomonee Falls, WI 53051

www.williamson-thermoflo.com

Form No. T-110 (12/23)



In the interest of continual improvement in product and performance, Thermoflo reserves the right to change specifications without notice.