



# Thermoflo

**13**  
**SEER**

## AIR CONDITIONERS

### Standard Features:

- Environmentally Friendly R-410a Refrigerant
- Durable Condenser Coil
- Liquid Line Filter Drier
- Sound Absorbing Injection Molded Top Cap
- High-Efficiency Compressors
- One Foot Print – 1.5 thru 5.0 Ton Sizes
- Easy-Serviceability – Single Screw Access Panel
- 5 Year Limited Compressor Warranty
- 5 Year Limited Warranty On Parts





## AIR CONDITIONERS

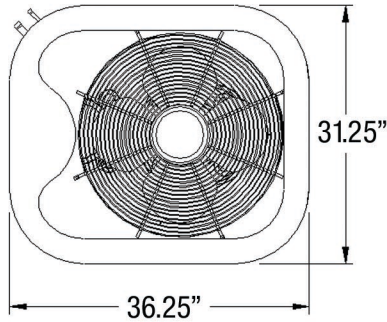
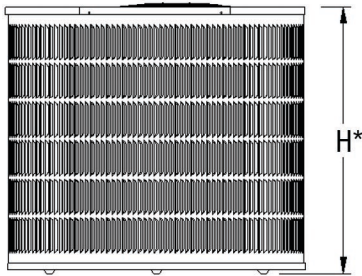

### Unit Specifications

Nominal Capacity (Ton)	1.5	2	2.5	3	3.5	4	5
Model Number	W4AC13018ASA1	W4AC13024ASA1	W4AC13030ASA1	W4AC13036ASA1	W4AC13042ASA1	W4AC13048ASA1	W4AC13060ASA1
Rated BTU/H	18,000	24,000	29,000	34,000	41,000	46,000	57,000
Seasonal Energy Efficiency Ratio (SEER)	13.0	13.0	13.0	13.0	13.0	13.0	13.0
Compressor Type	Compliant Scroll						
Compressor Manufacturer	Copeland						
Liquid Line Connection	3/8"	3/8"	3/8"	3/8"	3/8"	3/8"	3/8"
Suction Line Connection	3/4"	3/4"	3/4"	3/4"	7/8"	7/8"	7/8"
Refrigerant	R-410a	R-410a	R-410a	R-410a	R-410a	R-410a	R-410a
Cabinet	Fully Louvered Galvanized Steel with Powder Coat Protection						
*Cabinet Height (H Dimension in inches)	20.5"	20.5"	24.5"	24.5"	24.5"	24.5"	28.5"
Weight (lbs.)	150	151	152	170	201	203	218

### Optional Equipment: Centennial Oil Furnace Cased Cooling Coils

Centennial Oil Furnace Cased Cooling Coils

• Features:

Galvanized Steel Drain Pan

R-410A and R-22 Refrigerant compatible

High efficiency enhanced aluminum fins bonded to rifled copper tubing with aluminum end plates

Pressured tested to 450 lbs

Insulated cabinet with easy opening front access panel.

