

Thermoflo

TLB

Series 2

Ratings

91,000 to 119,000 Btuh Input

0.65 to 0.85 GPH #2 Fuel Oil

Temp-O-Matic Low Boy Oil Furnace

- ▣ AFUE's to 83.5%
- ▣ Heat exchanger
 - Heavy gauge "wrap-around" design
 - Front or rear flue - front flue can be vented from top or right side
 - Interior baffling for maximum efficiency
 - Spring-loaded observation port with test port
 - Heavy gauge burner mounting plate secured with studs and nuts
- ▣ Blower
 - Multi-speed direct drive
 - Slide-out blower/motor – easily removed for service
- ▣ Cabinet
 - Appliance finish powder coat paint
 - Heavy gauge with "Seal-Tite" construction
 - Foil-faced insulation for hand-cool surface
 - Fully-enclosed burner and controls
- ▣ Burner and controls
 - Factory-wired with simple plug-in connections
 - PSC motor
 - Solid state ignitor



Thermoflo

RATINGS

| Model | Input | Output | Firing rate | Installed nozzle | AFUE with electric damper | AFUE without electric damper | Blower size | Blower motor hp | Maximum cooling capacity | Ship wt. (pounds) | Blower CFM | |
|---------------------------|---------|---------|-------------|------------------|---------------------------|------------------------------|-------------|-----------------|--------------------------|-------------------|------------|------------|
| | (Btuh) | (Btuh) | (GPH) | | | | | | (tons) | | @ 0.25° WC | @ 0.50° WC |
| Direct-drive units | | | | | | | | | | | | |
| TLB-105 | 91,000 | 79,100 | 0.65 | | 83.5 | 81.0 | GT10-10 | 1/3 | 3 | 225 | 1050 | 975 |
| | 105,000 | 90,500 | 0.75 | ✓ | 82.0 | 80.5 | GT10-10 | 1/3 | 3 | 225 | 1150 | 1125 |
| | 119,000 | 101,500 | 0.85 | | 81.0 | 80.0 | GT10-10 | 1/3 | 3 | 225 | 1300 | 1150 |

NOTE: Filter sizes required: TLB-105 - (1) 10" x 20" & (1) 12" x 20"

DIMENSIONS

ALL DIMENSIONS IN INCHES

Rear flue shown

TOP VIEW

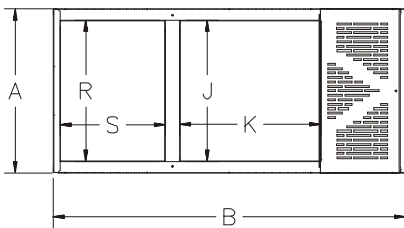

| Model | Furnace casing | | | Warm air supply | | Return air | | Flue pipe diam. |
|---------|----------------|---------|----------|-----------------|---------|------------|---------|-----------------|
| | Width A | Depth B | Height C | Width J | Depth K | Width R | Depth S | |
| TLB-105 | 23 | 49-1/4 | 38 | 19-3/4 | 19-3/4 | 19-3/4 | 14-3/4 | 6 |

Note: TLB furnaces are approved for "0" clearance to combustible construction. Refer to installation manual for details and proper installation.

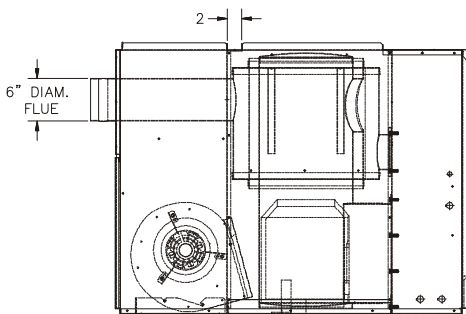

SIDE VIEW

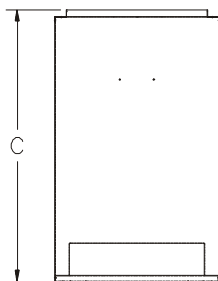

FRONT VIEW

EQUIPMENT

- Factory-assembled
- Hot-rolled steel heat exchanger, pressure tested to assure leak-tight construction
- Heavy 14-gauge heat exchanger
- Rugged 20-gauge cabinet with powder coat finish
- Leveling legs
- Air conditioning fan center
- Electrical box with external low-voltage terminal strip
- Limit control with continuous fan on selector switch
- Barometric damper provided
- High-efficiency flame retention burner (Beckett, Carlin, Riello)
- Optional two-stage fuel unit

ORDER CODE

WARRANTY

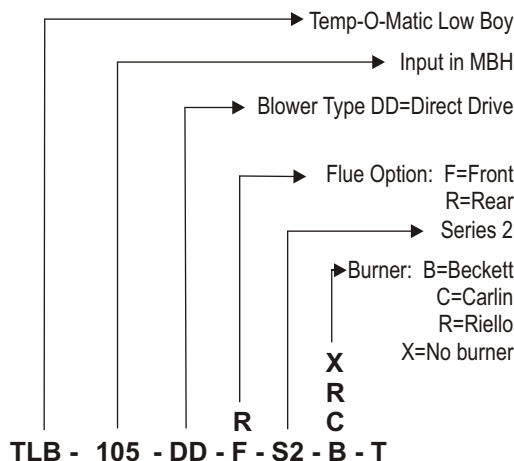

- Limited lifetime warranty on heat exchanger
- 5-year limited warranty on parts
- Optional 5- or 10-year parts and labor warranty



Thermoflo

8201 West Calumet Road • Milwaukee, WI 53223

www.williamson-thermoflo.com

Form No. T-605R1(0903)

