

Williamson

GSA

Series 2

Factory-Packaged (GSA-075 – GSA-238)

75,000 to 282,000 Btuh Input

Atmospheric (chimney) venting

Natural Gas



Gas-Fired Steam Boiler

- Spark (intermittent) pilot system
- Easy Service
 - One piece access door
 - All controls in easy reach
- High efficiency
 - Generous heating surface
 - Automatic vent damper
- Cast iron sections
- Rugged construction for long life
 - Stainless steel burners
 - Integral cast iron legs
 - Integral draft diverter
 - Insulated heavy-gauge steel jacket
 - Heavy-gauge aluminized steel flue collector



Williamson®

RATINGS

Model	Input (Btuh)	AHRI Certified Ratings				Boiler water content (gallons)	Chimney and breeching size	Boiler Shipping Weight (Pounds)
		Heating Capacity (Btuh) (1)	Net Ratings (Btuh) (2)		AFUE % (1)			
			Sq. Ft. steam	Steam BTUH				
GSA-075	75,000	62,000	196	47,000	82.0	8.4	5" I.D. x 20'	430
GSA-100	100,000	82,000	258	62,000	82.0	8.4	5" I.D. x 20'	430
GSA-125	125,000	103,000	321	77,000	82.0	9.8	6" I.D. x 20'	505
GSA-150	150,000	124,000	388	93,000	82.0	9.8	6" I.D. x 20'	505
GSA-175	175,000	145,000	454	109,000	82.0	11.2	7" I.D. x 20'	585
GSA-200	200,000	166,000	521	125,000	82.0	11.2	7" I.D. x 20'	585
GSA-238	238,000	198,000	621	149,000	82.0	12.6	8" I.D. x 20'	660
GSA-282	282,000	234,000	733	176,000	82.0	14.0	8" I.D. x 20'	735

1. Based on standard test procedures prescribed by the United States Department of Energy.
2. Net AHRI ratings are based on net installed radiation of sufficient quantity for the requirements of the building and nothing need be added for normal piping and pickup. Ratings are based on a piping and pickup allowance of 1.333. An additional allowance should be made for unusual piping and pickup loads.

- Contact your local dealer regarding information and parts for high altitude applications.
- Boiler model order code suffix: N-I (natural gas, intermittent pilot), P (probe LWCO)

DIMENSIONS

ALL DIMENSIONS IN INCHES

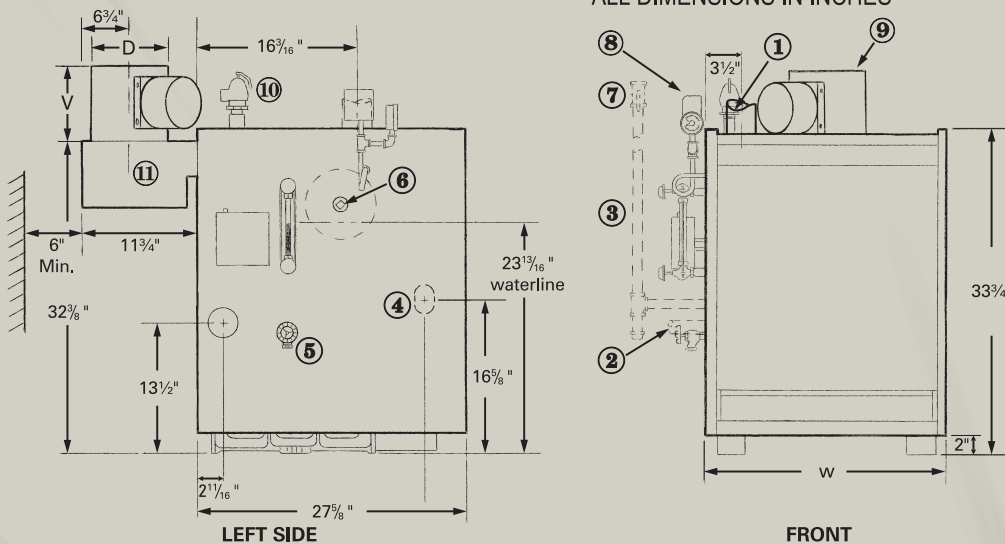

Boiler Model	V Damper Height	D Vent Diameter	W Jacket Width
GSA-075	6	5	17
GSA-100	6	5	17
GSA-125	6 1/2	6	21 1/4
GSA-150	6 1/2	6	21 1/4
GSA-175	9	7	25 1/2
GSA-200	9	7	25 1/2
GSA-238	9 1/2	8	29 3/4
GSA-282	9 1/2	8	34

- ① Supply piping 3" NPT Tapping (Note 1)
- ② Return piping 2 1/2" NPT Tapping (Note 1)
- ③ Gas supply piping
- ④ Gas supply entrance (right or left side)
- ⑤ Drain valve
- ⑥ Skim tapping
- ⑦ Manual main shutoff valve
- ⑧ Pressure limit control
- ⑨ Vent connection to vent damper
- ⑩ Relief valve
- ⑪ Draft diverted

Note 1: See boiler manual for recommended system supply and return piping sizes.

If field-installing a float-type low water cutoff, it must be connected only using the gauge glass tapings. No other location is acceptable.

EQUIPMENT

- Factory tested
- Insulated heavy-gauge steel jacket
- Factory-assembled cast iron sections, boiler fully assembled (except GSA-282)
- Integral horizontal draft diverter
- 24-VAC combination gas valve
- Gauge glass and guard assembly
- Pressure gauge and siphon assembly
- Stainless steel burners
- Pressure limit control
- Probe low water cutoff
- High temperature limit control
- Automatic vent damper
- 15 PSIG ASME relief valve
- Drain Valve
- Spark-ignited (intermittent) pilot system
- Electronic ignition/flame supervisory control



Williamson®

N93 W14635 Whittaker Way, Menomonee Falls, WI 53051

www.williamson-thermoflo.com



In the interest of continual improvement in product and performance, Williamson reserves the right to change specifications without notice.

Form No. W-504 (01/21)