

Williamson

GW

Series 3

Induced-Draft Combustion System

Factory-Packaged

48,000 to 190,000 Btuh Input

Natural Gas or Propane

Gas-Fired Water Boiler

- Low water cut-off included
- Versatile
 - Induced-draft design allows sidewall or chimney venting
- Inferred heat program providing automatic adjustment of boiler water temperature to match demand
- Spark (intermittent) pilot system
- Control module with indicator lights
- Easy service
 - One-piece access door
 - All controls in easy reach
- Cast iron sections with built-in air separator
- Compact Design
- Insulated heavy-gauge steel jacket



Williamson®

RATINGS

Model	Input (Btuh)	AHRI Certified Ratings			Boiler water content (gallons)	Vent Size: Direct exhaust venting	Chimney/breeching size: Atmospheric venting	Circulator flange size (Recommended supply & return pipe size, NPT)
		Heating Capacity (Btuh) (1)	Net Ratings (Btuh) (2)	AFUE % (1)				
GWI-048	48,000	41,000	35,000	84.0	1.5	3"	4"	3/4"
GWI-058	58,000	49,000	42,000	84.0	1.5	3"	4"	1"
GWI-090	90,000	77,000	66,000	84.0	2.1	3"	5"	1"
GWI-119	119,000	102,000	88,000	84.0	2.7	3"	5"	1"
GWI-158	158,000	135,000	117,000	84.0	3.3	3"	5"	1 1/4"
GWI-190	190,000	162,000	140,000	84.0	3.8	3"	6"	1 1/4"

1. Based on standard test procedures prescribed by the United States Department of Energy.
2. Net AHRI ratings are based on net installed radiation of sufficient quantity for the requirements of the building and nothing need be added for normal piping and pickup. Ratings are based on a piping and pickup allowance of 1.15. An additional allowance should be made for unusual piping and pickup loads.

- Contact your local dealer regarding information and parts for high altitude applications.
- Boiler model order code suffix: N (natural gas) L (Propane) T (Taco circulator)

DIMENSIONS

ALL DIMENSIONS IN INCHES

GWI boilers are CSA design certified for installation on combustible flooring. (Do not install on carpeting)

VENTING:
When connecting boiler as direct exhaust, use only AL29-4C venting per instructions in Boiler Manual.

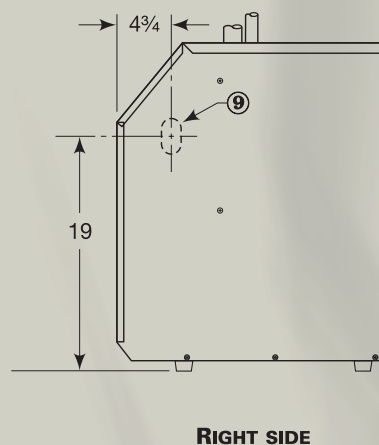
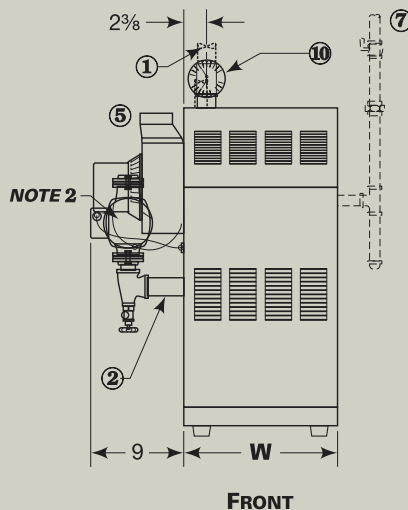
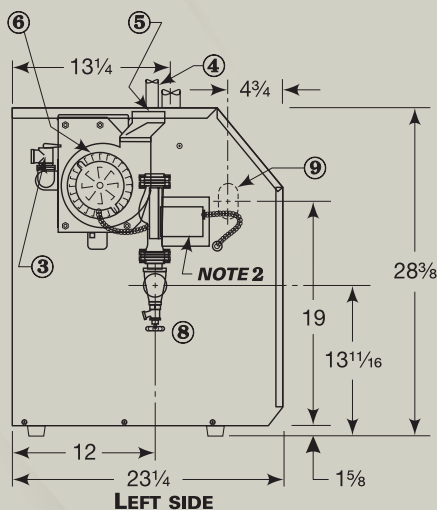

Boiler Model	W Width
GWA-048	10
GWA-058	10
GWA-090	13
GWA-119	16
GWA-158	19
GWA-190	22

- ① Supply piping (Note 1)
- ② Return piping (Note 1)
- ③ Relief valve, 3/4" NPT
- ④ 1/2" NPT to expansion tank/air vent
- ⑤ Vent connection, 3" diameter
- ⑥ Inducer
- ⑦ Gas supply piping
- ⑧ Drain valve
- ⑨ Gas supply entrance (right or left side)
- ⑩ Pressure/temperature gauge (in tee on supply)

Note 1: Boiler supply and return tapings are 1 1/4" NPT. Circulator flanges shipped with boiler are sized to recommended pipe size listed in RATINGS table, above.

Note 2: Boiler circulator is shipped loose. Circulator may be mounted on either boiler supply or return piping.

EQUIPMENT

- Factory tested
- Insulated extended steel jacket
- Cast iron sections with built-in air separator
- Induced-draft blower assembly
- Air pressure switch
- Stainless steel burners
- Electrical junction box
- 24-VAC combination gas valve
- Boiler control module with indicator lights
- Taco 007 circulator
- High temperature limit control
- 30 PSIG ASME relief valve
- Combination pressure/temperature gauge
- Spark-ignited (intermittent) pilot system
- Electronic ignition/flame supervisory control
- Low water cut-off included for field installation



In the interest of continual improvement in product and performance, Williamson reserves the right to change specifications without notice.



N93 W14635 Whittaker Way, Menomonee Falls, WI 53051

www.williamson-thermoflo.com

Form No. W-002 (10/20)