

Williamson

Multi-Speed Direct Drive
or
Variable Speed ECM Motor

Ratings - 2 Sizes

77,000 to 112,000 Btuh Input
0.55 to 0.80 GPH #2 Fuel Oil



PLB

098/112

Low Profile
Packaged Low-Boy
Oil Furnace

- AFUE's up to 87.5%
- Rear Flue
- Stainless steel heat exchanger
- Tube style aluminized steel secondary heat exchanger
- Continuous fan on switch
- Large rear access clean out secured with studs and nuts
- Burner and controls
 - Factory-wired with simple plug-in connections
 - PSC motor
 - Solid state ignitor and solenoid valve
- Cabinet
 - Appliance finish powder coat paint
 - Heavy gauge construction
 - Foil-faced insulation



Williamson[®]

RATINGS

Model	Firing Rate	Input	Output	Direct Drive Blower (PCS)				Energy Star Certified Variable Speed Blower (ECM) 				Maximum cooling capacity (tons)
				Blower size	Blower motor hp	Blower CFM		Blower Size	Blower Motor hp	Blower CFM Range		
						@ 0.25 WC	@ 0.50 WC			min	max	
PLB-098	0.55	77,000	65,000	10-10	1/3	1010	915	10-10	1/2	750	1350	3
	0.70	98,000	81,000	10-10	1/3	1255	1180	10-10	1/2	750	1350	3
PLB-112	0.68	95,200	81,100	12-9	1/2	1090	1010	12-9	3/4	900	1450	4
	0.80	112,000	94,100	12-9	1/2	1200	1160	12-9	3/4	900	1450	4

* As an Energy Star partner, Williamson has determined that this product with Variable Speed Motor meets Energy Star guidelines for energy efficiency.
 Note: Filter size required. PLB-098 (1) 20" x 20" - PLB-112 (1) 20" x 20" or (2) 16" x 20". Refer to installation manual for detailed air flow information.

PLB-098 Chimney Venting		
Burner	Input (GPH)	AFUE %
Beckett AFG	0.55	85.7%
	0.70	85.1%
Carlin EZ-LF	0.55	85.9%
	0.70	85.2%
Riello 40-F3	0.55	86.6%
	0.70	85.2%

PLB-112 Chimney Venting		
Burner	Input (GPH)	AFUE %
Beckett AFG	0.68	87.1%
	0.80	86.5%
Carlin EZ-LF	0.68	87.5%
	0.80	86.4%
Riello 40-F3	0.68	86.6%
	0.80	86.1%

DIMENSIONS

ALL DIMENSIONS IN INCHES

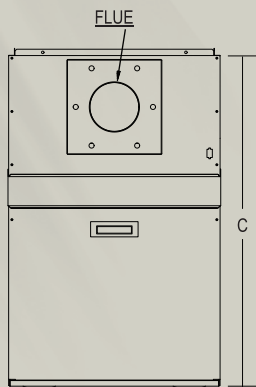

BACK VIEW

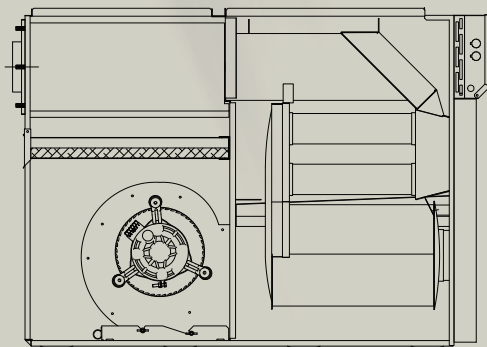

SIDE VIEW

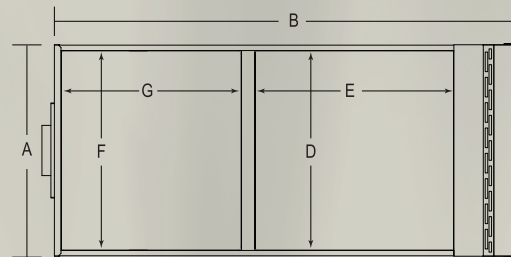

TOP VIEW

Model	Furnace Casing			Warm air supply		Return air (side)		Flue Pipe diam.	Shipping Weight (pounds)
	Width A	Depth B	Height C	Width D	Depth E	Width F	Depth G		
PLB-098	21	47	34	20	20	18	20	5	175
PLB-112	21	48	33	19-3/4	19-3/4	19-3/4	19-3/4	5	195

Note: Refer to installation instructions for details and proper installation.

EQUIPMENT

- Factory-assembled
- Rugged 22-gauge cabinet with powder coat finish
- Stainless steel heat exchanger
- Variable Speed ECM fan center compatible with 2-stage A/C compressors
- Continuous fan on selector switch
- High-efficiency flame retention burner (Beckett AFG, Carlin or Riello)
- Easy access panel for wiring and control board access



In the interest of continual improvement in product and performance, Williamson reserves the right to change specifications without notice.

WARRANTY

- 20-year limited warranty on heat exchanger
- 5-year limited warranty on parts
- Optional 5- or 10-year parts and labor warranty



Williamson

N93 W14635 Whittaker Way, Menomonee Falls, WI 53051

www.williamson-thermoflo.com

Form No. W-114 (12/23)