

GSA

Gas-Fired Steam Boilers



Boiler Manual

Contents	Page
1 Prepare boiler location.....	2
2 Prepare boiler	8
3 Install piping	11
4 Install controls	14
5 Install gas piping	15
6 Field wiring	16
7 Start-up.....	19
8 Operation	23
9 Checkout procedure.....	28
10 Service and maintenance.....	29
11 Troubleshooting.....	33
12 Replacement parts	38
13 Dimensions	42
14 Ratings.....	43

NOTICE

INSTALLER —

Spark ignition boilers — All the information from GSA Spark Ignition Control Supplement, part number 550-141-971, for general installation, maintenance information operating instructions, troubleshooting and other additional information for GSA boilers equipped with spark ignition has now been added to this manual.

Hazard definitions

▲ DANGER Hazards that will cause severe personal injury, death or substantial property damage.

▲ CAUTION Hazards that will or can cause minor personal injury or property damage.

▲ WARNING Hazards that can cause severe personal injury, death or substantial property damage.

NOTICE Special instructions on installation, operation or maintenance that are important but not related to personal injury or property damage.

▲ WARNING **INSTALLER** — Read all instructions before installing. **Read page 2 first.** Follow all instructions in proper order to prevent personal injury or death.

- Consider piping and installation when determining boiler location.
- Any claims for damage or shortage in shipment must be filed immediately against the transportation company by the consignee.
- GSA boilers cannot be adapted for heater use.

▲ WARNING **USER** — Please read the following. Failure to comply could result in severe personal injury, death or substantial property damage.

- **This document is for use only by your qualified heating installer/service technician.**
- Please see the User's Information Manual for your reference.
- Have the boiler serviced by a qualified service technician, at least annually.

▲ WARNING This manual must only be used by a **qualified heating installer/service technician.** Failure to comply could result in severe personal injury, death or substantial property damage.

NOTICE

When calling or writing about the boiler — Please have: • boiler model number from the boiler rating label and • Consumer Protection (CP) number from the boiler jacket. You may list the CP number in the space provided on the "Installation and service certificate" found on page 28.

Read this first!

▲WARNING Failure to adhere to the guidelines below can result in severe personal injury, death or substantial property damage.

▲WARNING The boiler contains ceramic fiber and fiberglass materials. Use care when handling these materials per instructions on page 22 of this manual. Failure to comply could result in severe personal injury.

When servicing boiler —

1. To avoid electric shock, disconnect electrical supply before performing maintenance.
2. To avoid severe burns, allow boiler to cool before performing maintenance.

Boiler operation —

3. Do not block flow of combustion or ventilation air to boiler.
4. Should overheating occur, turn off or disconnect electrical supply to boiler and shut off the gas supply at a location external to the appliance, if possible.
5. Do not use this boiler if any part has been under water. Immediately call a qualified service technician to inspect the boiler and to replace any part of the control system and any gas control that has been under water.

Boiler water —

6. DO NOT use petroleum-based cleaning or sealing compounds in boiler system. Water seal deterioration will occur, causing leakage between boiler sections, circulator flanges, diaphragm tanks or other system components. This can result in substantial property damage.
7. DO NOT use “homemade cures” or “boiler patent medicines”. Serious damage to boiler, personnel and/or property may result.
8. Continual fresh makeup water will reduce boiler life. Mineral buildup in sections reduces heat transfer, overheats cast iron, and causes section failure. Addition of oxygen and other gases can cause internal corrosion. Leaks in boiler or piping must be repaired at once to prevent makeup water.
9. Do not add cold water to hot boiler. Thermal shock can cause sections to crack.

Freeze protection fluids —

NEVER use automotive or standard glycol antifreeze. Use only freeze-protection fluids made for hydronic systems. Follow all guidelines given by the antifreeze manufacturer. Thoroughly clean and flush any re-placement boiler system that has used glycol before installing the new boiler.

Saltwater Damage — The exposure of boiler components to saltwater can have both immediate and long-term effects. While the immediate effects of saltwater damage are similar to those of freshwater (shorting out of electrical components, washing out of critical lubricants, etc.), the salt and other contaminants left behind can lead to longer term issues after the water is gone due to the conductive and corrosive nature of the salt residue. Therefore, Weil-McLain equipment contaminated with saltwater or polluted water will no longer be covered under warranty and should be replaced.

Electrical Damage — If any electrical component or wiring came into contact with water, or was suspected to have come into contact with water, replace the boiler with a new Weil-McLain boiler.

▲CAUTION Frozen Water Damage Hazard

Residences or buildings that are unattended in severely cold weather, boiler system components failures, power outages, or other electrical system failures could result in frozen plumbing and water damage in a matter of hours. For your protection, take preventative actions such as having a security system installed that operates during power outages, senses low temperature, and initiates an effective action. Consult with your boiler contractor or a home security agency.

1 Prepare boiler location

Codes & Checklist

Installations must follow these codes:

- Local, state, provincial, and national codes, laws, regulations and ordinances.
- National Fuel Gas Code, ANSI Z223.1/NFPA 54 – latest edition.
- Where required by the authority having jurisdiction, the installation must conform to the Standard for Controls and Safety Devices for Automatically Fired Boilers, ANSI/ASME CSD-1 – latest edition.
- National Electrical Code ANSI/NFPA 70 – latest edition.

Certification

NOTICE The GSA boiler gas manifold and controls met safe operating and other performance criteria when boiler underwent tests specified in ANSI Z21.13 – latest edition.

Before locating the boiler:

- Check for nearby connection to:
 - Venting connections
 - Gas supply piping
 - Electrical power
- Check area around boiler. Remove any combustible materials, gasoline and other flammable liquids.

▲WARNING Failure to keep boiler area clear and free of combustible materials, gasoline and other flammable liquids and vapors can result in severe personal injury, death or substantial property damage.

- Boiler must be installed so that gas control system components are protected from dripping or spraying water or rain during operation or service.
- If new boiler will replace existing boiler, check for and correct system problems, such as:
 - System leaks causing oxygen corrosion or section cracks from hard water deposits.

▲WARNING This manual must only be used by a qualified heating installer/service technician. Read these instructions completely before beginning the installation. Failure to follow these instructions can cause severe personal injury, death or substantial property damage.

Improper installation, adjustment, alteration, service or maintenance can cause property damage, personal injury, exposure to hazardous materials, or loss of life. Refer to the User's Information Manual provided with this boiler. Installation and service must be performed by a qualified installer, service agency or the gas supplier who must read and follow the supplied instructions before installing, servicing or removing this boiler. This boiler contains materials that have been identified as carcinogenic, or possibly carcinogenic, to humans.

1 Prepare boiler location continued

Clearances

Recommended **SERVICE** clearances

1. Provide minimum clearances for cleaning and servicing the boiler and for access to controls and components as listed in the table at right.
2. Provide at least screwdriver clearance to jacket front panel screws for removal of front panel for inspection and minor service. If unable to provide at least screwdriver clearance, install unions and shutoff valves in system so boiler can be moved for servicing.

Clearance for service	Minimum
Clearance to boiler jacket	
Top (for cleaning flue ways)	46"
Front (for access to controls and components)	18"
Back	6"
Left side (for cleaning and servicing)	24"
Right side	6"

Minimum clearances to **COMBUSTIBLE** materials

General clearances — All installations

1. See the table at right for clearances to boiler and system components.
2. Clearances to Type B vent materials are as specified by the vent manufacturer.

Clearance to combustible materials	Minimum
Clearance to boiler jacket	
Top	46"
Front (provides means of access)	3"
Back	6"
Left side (provides means of access)	4"
Right side	4"
Clearance to piping and vent components	
Water and steam pipes	1/2"
Vent pipe (other than Type B vent)	6"
Type B vent piping	Per B vent Manufacturer
Vent damper	6"

Alcove (not closet) installations only



GSA boilers are not approved for closet installation — only for alcove installation, with minimum clearances to combustible surfaces as shown in the table at right. See Figure 1. The front side must be completely open — that is, a 3-walled room.

Figure 1 Alcove installations

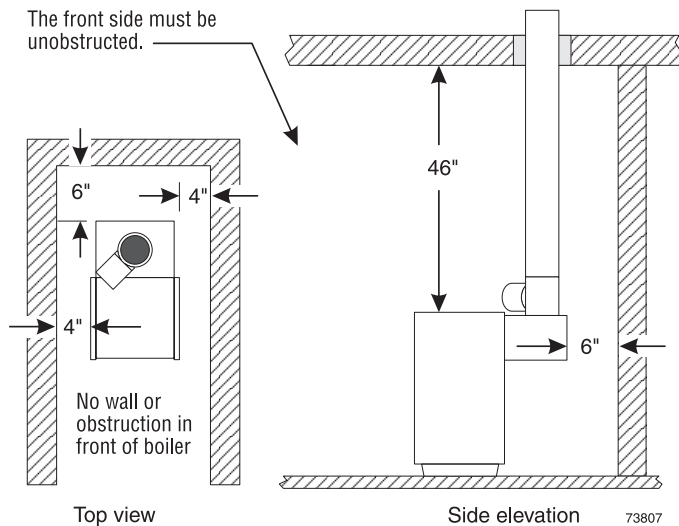

1 Prepare boiler location continued

Residential garage installation

Take the following special precautions when installing the boiler in a residential garage. If the boiler is located in a residential garage, per ANSI Z223.1:

- Mount the boiler a minimum of 18 inches above the floor of the garage to assure the burner and ignition devices will be no less than 18 inches above the floor.
- Locate or protect the boiler so it cannot be damaged by a moving vehicle.

Flooring and foundation

WARNING Do not install boiler on combustible flooring or carpeting even if a concrete or aerated foundation is used. Fire can result, causing severe personal injury, death or substantial property damage.

1. Provide a solid brick or minimum 2-inch thick concrete foundation pad if any of the following is true:
 - floor can become flooded.
 - the boiler mounting area is not level.
2. See Table 1 for minimum foundation dimensions.
3. Use a foundation with airways when:
 - Electrical wiring or telephone cables buried in the concrete floor of the boiler room.
 - Concrete floor is “green”.
 - Water is channeled under the concrete.

Table 1 Minimum foundation size

Boiler model	Minimum foundation length	Minimum foundation “L” width
GSA-075 — GSA-100	29 5/8”	19”
GSA-125 — GSA-150	29 5/8”	23 1/4”
GSA-175 — GSA-200	29 5/8”	27 1/2”
GSA-250	29 5/8”	31 3/4”
GSA-300	29 5/8”	36”

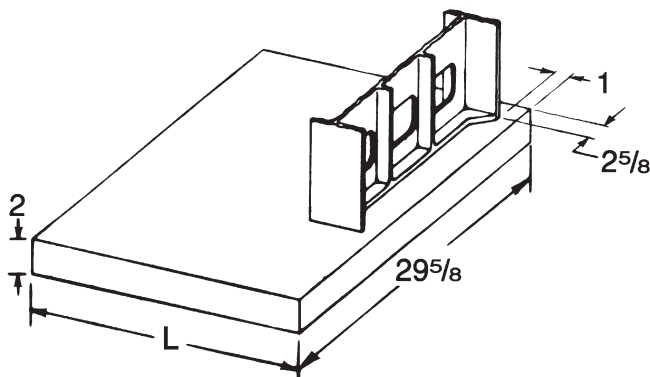

Vent System

WARNING Failure to follow all instructions can result in flue gas spillage and carbon monoxide emissions, causing severe personal injury or death.

DANGER Inspect existing chimney before installing boiler. Failure to clean or replace perforated pipe or tile lining will cause severe personal injury or death.

DANGER Do not alter boiler draft hood or place any obstruction or non-certified vent damper in breeching or vent system. CSA certification will become void. Flue gas spillage and carbon monoxide emissions will occur causing severe personal injury or death.

NOTICE The following requirements apply when you remove an existing boiler from a vent system shared with other appliances. **If the new boiler will not use the common vent, you must test** (as described below) each remaining appliance — operating by itself — to verify that the vent system operates adequately.

When removing boiler from existing common vent system:

At the time of removal of an existing boiler, the following steps shall be followed with each appliance remaining connected to the common venting system placed in operation, while the other appliances remaining connected to the common venting system are not in operation.

- a. Seal any unused openings in the common venting system.
- b. Visually inspect the venting system for proper size and horizontal pitch and determine there is no blockage or restriction, leakage, corrosion or other deficiencies which could cause an unsafe condition.
- c. Test vent system — Insofar as is practical, close all building doors and windows and all doors between the space in which the appliances remaining connected to the common venting system are located and other spaces of the building. Turn on clothes dryers and any appliance not connected to the common venting system. Turn on any exhaust fans, such as range hoods and bathroom exhausts, so they will operate at maximum speed. Do not operate a summer exhaust fan. Close fireplace dampers.
- d. Place in operation the appliance being inspected. Follow the operating instructions. Adjust thermostat so appliance will operate continuously.
- e. Test for spillage at draft hood relief opening after 5 minutes of main burner operation. Use the flame of a match or candle.
- f. After it has been determined that each appliance remaining connected to the common venting system properly vents when tested as outlined above, return doors, windows, exhaust fans, fireplace dampers, and any other gas-burning appliance to their previous conditions of use.

Any improper operation of the common venting system should be corrected so the installation conforms with the National Fuel Gas Code, ANSI Z223.1/NFPA 54 and/or CAN/CGA B149, Installation Codes. When resizing any portion of the common venting system, the common venting system should be resized to approach the minimum size as determined using the appropriate tables in the National Fuel Gas Code, ANSI Z223.1/NFPA 54 and/or CAN/CGA B149, Installation Codes.

1 Prepare boiler location continued

Vent System

Chimney or vent requirements

1. Venting must be installed according to the National Fuel Gas Code, ANSI Z223.1 – latest edition and applicable building codes. Canadian installations must comply with B149.1 or B149.2 Installation Codes.
2. See “Ratings” on page 43 for minimum chimney or vent sizes. Chimney or vent termination:
 - A chimney, or any vent other than a Type B vent with listed vent cap, must extend at least 3 feet above the highest point where it passes through a roof of a building, and at least 2 feet higher than any portion of a building within a horizontal distance of 10 feet.
 - Type B vents with listed caps may terminate as in Figure 2 if no closer than 8 feet from a vertical wall or similar obstruction.
 - Otherwise, Type B vents must terminate at least 2 feet above the roof penetration and at least 2 feet higher than any portion of a building within 10 feet.
3. A lined chimney is preferred and must be used when required by local, state, provincial and national codes, laws, regulations and ordinances. Vitreous tile linings with joints that prevent retention of moisture and linings made of noncorrosive materials are best. Advice for flue connections and chimney linings can be obtained from local gas utility. Type B double-wall metal vent pipe or single-wall vent pipe may be used as a liner.
4. Cold masonry chimneys, also known as outside chimneys, typically have one or more walls exposed to outside air. When any atmospheric gas-fired boiler with automatic vent damper is vented through this type of chimney, the potential exists for condensation to occur. Condensation can damage a masonry chimney. The following are recommended to prevent possible damage.
 - a. Line chimney with corrosion-resistant metal liner such as AL29-4C® single-wall stainless steel or B-vent. Size liner per National Fuel Gas Code ANSI Z223.1–latest edition.
 - b. Provide drain trap to remove any condensate.
5. Where two or more gas appliances vent into a common chimney or vent, equivalent area should be at least equal to area of vent outlet on largest appliance plus 50 percent of vent outlet area of additional appliances.

Figure 2 Terminations with Type B vent fitted with listed cap, provided vent is at least 8 feet from any vertical wall or similar obstruction locations

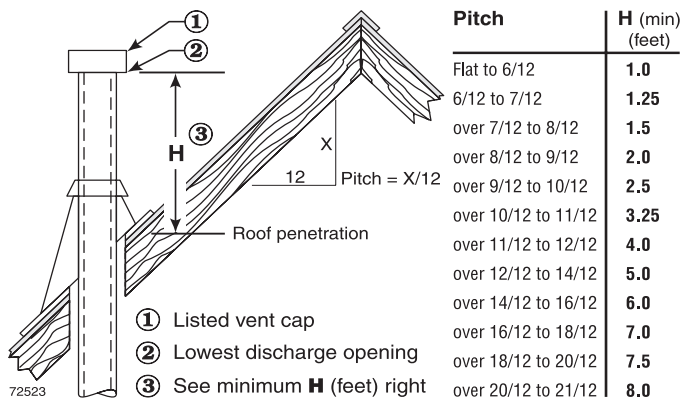

Air contamination

Please review the following information on potential combustion air contamination problems.

See Table 2 for products and areas which may cause contaminated combustion air.

WARNING To prevent potential of severe personal injury or death, check for products or areas listed below before installing boiler. If any of these contaminants are found:

- Remove contaminants permanently.
- OR –
- Isolate boiler and provide outside combustion air. See national, provincial or local codes for further information.

Table 2 Corrosive contaminants and likely locations

Products to avoid
Spray cans containing chloro/fluorocarbons
Permanent wave solutions
Chlorinated waxes/cleaners
Chlorine-based swimming pool chemicals
Calcium chloride used for thawing
Sodium chloride used for water softening
Refrigerant leaks
Paint or varnish removers
Hydrochloric acid/muriatic acid
Cements and glues
Antistatic fabric softeners used in clothes dryers
Chlorine-type bleaches, detergents, and cleaning solvents found in household laundry rooms
Adhesives used to fasten building products and other similar products
Areas likely to have contaminants
Dry cleaning/laundry areas and establishments
Swimming pools
Metal fabrication plants
Beauty shops
Refrigeration repair shops
Photo processing plants
Auto body shops
Plastic manufacturing plants
Furniture refinishing areas and establishments
New building construction
Remodeling areas
Garages with workshops
Buildings under construction (where air is contaminated with particulates)

1 Prepare boiler location continued

Air openings

WARNING Provide adequate combustion and ventilation air to assure proper combustion and reduce the risk of severe personal injury, death or substantial property damage caused by flue gas spillage and carbon monoxide emissions.

Combustion air and ventilation openings must comply with the National Fuel Gas Code, ANSI Z223.1 – latest edition, or applicable local building codes.

Air opening sizes in the following are given in free area (after correction for louver obstruction).

Option 1 — Provide (2) openings:

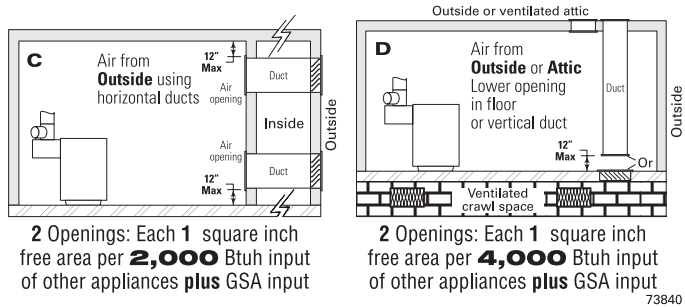
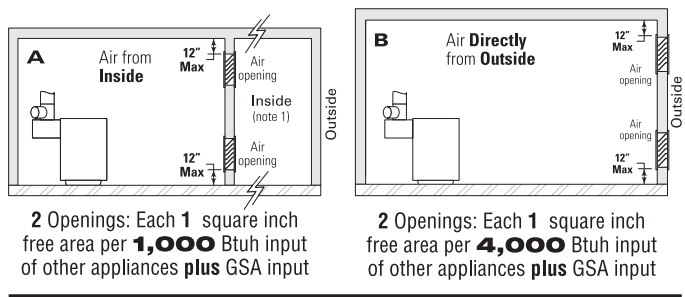

Option 2 — Provide (1) opening:

A single combustion air opening can be used, provided:

- The opening must commence within 12 inches of the ceiling.
- The boiler must have clearances of at least 1 inch from both sides and back, and 6 inches from the front.
- The opening must connect directly to the outdoors or to a space that communicates directly to the outdoors.
- The air can be provided through a direct opening or through a horizontal or vertical duct.
- The free area of the opening must be at least equal to the sum of all vent connectors in the space.
- The free area of the opening must be at least 1 square inch per 3000 Btu/hr input rating of all equipment located in the space.

Tight construction — Definition:

Tight construction means (per ANSI Z223.1):

- Walls and ceilings exposed to the outside atmosphere have a continuous water vapor retarder with a rating of 1 perm or less with openings gasketed. **AND**
- Weather-stripping has been added on openable windows and doors. **AND**

- Caulking or sealants are applied to areas such as joints around windows and door frames, between sole plates and floors, between wall-ceiling joints, between wall panels, at penetrations for plumbing, electrical, and gas lines, and in other openings.

Tight construction requirements

If building is of tight construction and air is taken from inside the building, provide two openings in building outside wall, one within 12 inches of ceiling, the other within 12 inches of the floor. Each opening must have a minimum free area of 1 square inch per 1,000 Btuh of all appliances in the building.

Exception

NO combustion air openings are needed when the boiler (and other appliances) are installed in a space with a volume NO LESS than 50 cubic feet per 1,000 Btuh of all installed appliances. Sum the total input of all appliances in MBH (1,000's of Btuh) and multiply this number times 50. Building must not be of tight construction (see above).

Example: For total input of 100 MBH (100,000 Btuh), minimum volume is $50 \times 100 = 5,000$ cubic feet. At a ceiling height of 8 feet, space must have at least $5,000 \div 8 = 625$ square feet (25 feet x 25 feet, for instance).

Exhaust fans and air movers

The appliance space must never be under a negative pressure. Always provide air openings sized not only to the dimensions required for the firing rate of all appliances, but also to handle the air movement rate of the exhaust fans or air movers using air from the building or space.

Motorized air dampers

If the air openings are fitted with motorized dampers, electrically interlock the damper to:

- Prevent the boiler from firing if the damper is not fully open.
- Shut the boiler down should the damper close during boiler operation.

To accomplish this interlock, wire an isolated contact (proving the damper open) in series with the thermostat input to the boiler. The boiler will not start if this damper is closed, and will shut down should damper close during operation.

Placement and setup

Place boiler/crate near position

1. Leave boiler in crate and on pallet until installation site is ready.
2. Move entire crate and pallet next to selected location.
3. Remove crate. **Leave boiler on pallet.**
4. Unbolt boiler from pallet.
5. Remove boiler from pallet.

1 Prepare boiler location

continued

Setup - continued

Inspect orifices and burners

1. Remove front jacket door. Remove base access panel (see Figure 25, item 14, page 38).
2. Check for correctly-sized manifold orifices. See Table 3 for sizing. (The orifice size is stamped on the orifice spud barrel.)

⚠ DANGER Correctly-sized manifold orifices must be used. Failure to do so will result in severe personal injury, death or substantial property damage.

3. Level and straighten burners.

⚠ DANGER Burners must be properly seated in slots in burner rest with their openings face up. Main burner orifices must inject down center of burner. Failure to properly seat burners will result in severe personal injury, death or substantial property damage.

4. Reinstall base access panel.

⚠ CAUTION Do not operate boiler without access panel secured in place. Failure to comply could cause momentary flame rollout on ignition of main flame, resulting in possible fire or personal injury hazard.

Table 3 Manifold orifice sizing

Location	Natural gas	
	Sea level – 2,000 ft. 2.45 mm	over 2,000 ft. (Note 1)
U.S.		
Note 1: For U.S. elevations above 2,000 feet, contact your local supplier for detail.		

Pressure test

Perform hydrostatic pressure test

Pressure test boiler before attaching water or gas piping or electrical supply.

Prepare boiler for test

1. Plug tappings or openings.
2. Do not use gauge supplied with boiler for pressure testing. Install gauge with appropriate range.

Fill and pressure test

1. Fill boiler with water. Vent all air. Test boilers between 45-50 psi.

⚠ WARNING Do not leave boiler unattended. A cold water fill could expand and cause excessive pressure resulting in severe personal injury, death or substantial property damage.

2. Check for stable gauge pressure for more than 10 minutes. Visually check for leaks if gauge pressure drops.

Drain and remove fittings

1. Drain boiler and repair leaks if found.

⚠ WARNING Leaks must be repaired at once. Failure to do so can damage boiler, resulting in substantial property damage.

Pressure test - continued

⚠ DANGER Do not use petroleum based cleaning or sealing compounds in boiler system. Severe damage to boiler will result, causing substantial property damage.

2. Retest boiler after repairing leaks.
3. Remove plugs from any tappings that will be used for controls and accessories. Refer to Table 4 and Figure 3.

NOTICE Float-type low water cutoff — If field installing a float-type low water cutoff, it must be piped only to the gauge glass tappings, items H, Figure 3. The tappings are spaced 9" on center. Use only float-type low water cutoffs with quick-connect hookups that will provide a low water cutoff point no higher than 2" above the center of the bottom tapping. See Figure 16, page 14, for a typical installation.

Table 4 Control tapping

Location	Size	Description
C	3/4"	Probe-type low water cutoff
D	3/4"	Drain
E	3/4"	Relief valve
G	3/4"	Plugged
H	1/2"	Gauge glass and /or optional low water cutoff
J (See Note)	3/8"	Tricock tappings
L	1/2"	Siphon, pressure gauge, high limit control
S	1 1/2"	Skim tapping

Note: Available only on special request.

Figure 3 Control tapping locations

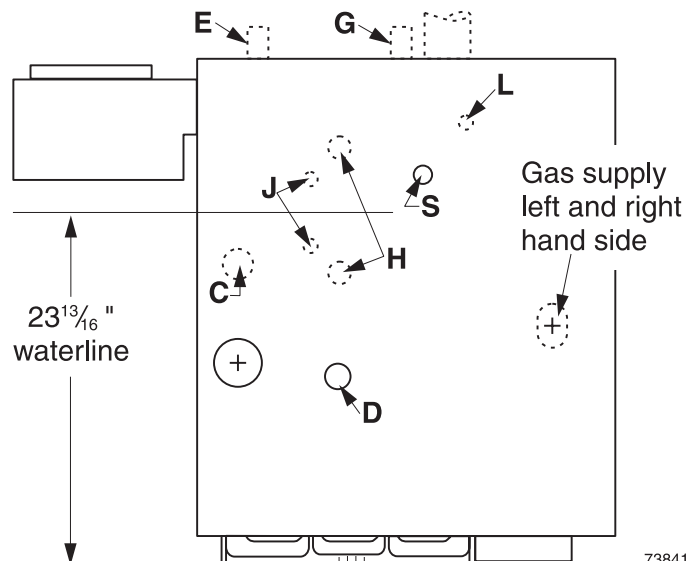

2 Prepare boiler

Installation of flue collector hood

(Factory installed on GSA boilers up to GSA-300)

Set flue collector hood on boiler as shown in Figure 4. Use boiler cement furnished to provide gas-tight seal.

WARNING Failure to maintain gas-tight seal can cause flue gas spillage and carbon monoxide emissions, resulting in severe personal injury or death.

Figure 4 Flue collector hood

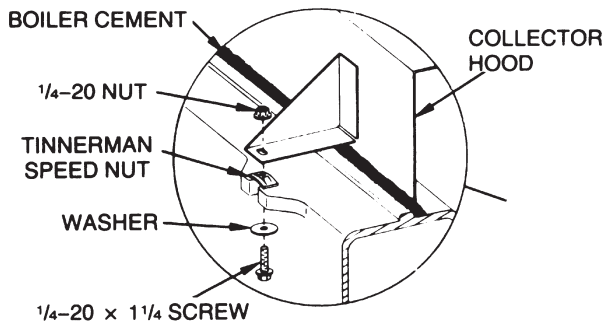

Installation of rear base panels

(Factory installed on GSA boilers up to GSA-300)

See Figure 5. Fasten rear base panel (7 5/16 inch high) and rear base channel to section assembly. Seal with boiler cement along top of insulation panels.

WARNING Failure to maintain gas-tight seal can cause flue gas spillage and carbon monoxide emissions, resulting in severe personal injury or death.

Figure 5 Rear base panel and base channel

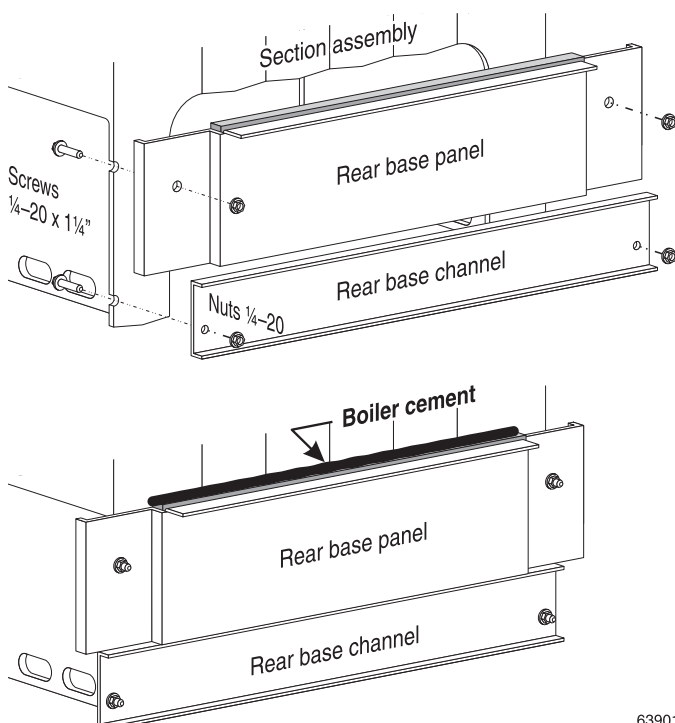

Installation of drawer assembly, front base panels –

1. See Figure 6. Fasten front base panel (6 1/8 inch high) and rear base channel to section assembly. Seal with boiler cement along top of insulation panels.
2. The burner drawer assembly consists of the burner drawer, main burners, gas manifold, pilot burner, etc.
3. Check for proper orifice sizing from Figure 3, page 7.

WARNING Proper orifices must be used. Failure to do so will cause severe personal injury, death or substantial property damage.

4. Place burners in the drawer assembly as shown in Figures 7 and 8.
5. Slide the drawer assembly under the front base panel and attach to the section assembly as shown in Figure 9.
6. Level and straighten burners.

WARNING Burners must be properly seated in slots in back burner support with openings facing up. Gas orifices must inject down center of burner. Failure to properly seat burners will result in severe personal injury, death or substantial property damage.

7. Install rollout thermal fuse element with wire terminals facing up on front access panel as shown in Figure 10. Wire per wiring diagram in Figure 20, page 18.

Inspect burners – GSA 300 boiler

1. All units except GSA-300 are factory-assembled, but the burners and base panels should be inspected to ensure they are in good condition.
2. Remove the access panel (Figure 10) and inspect the burners per step 6 above. Replace the access panel.

2 Prepare boiler continued

Figure 6 Front base panel

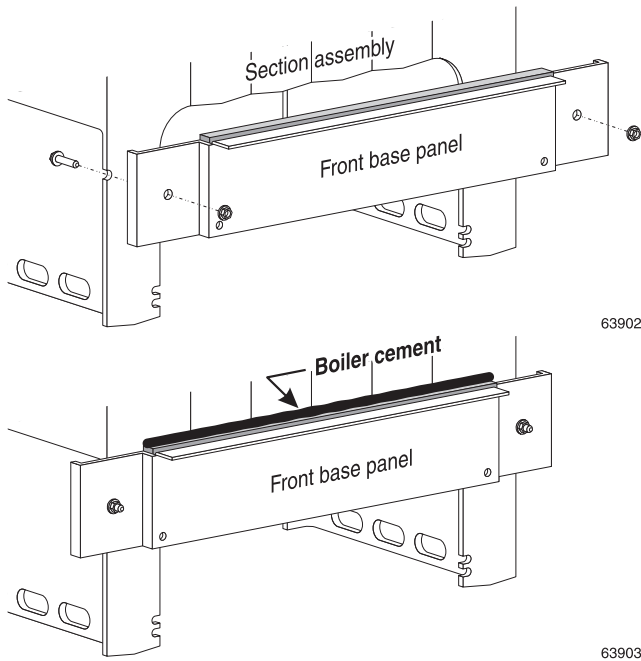

Figure 7 Burner drawer assembly

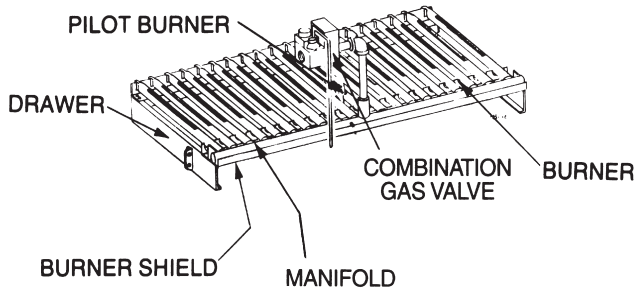

Figure 8 Burner and pilot burner location

Legend:

○ Burner

⊗ Pilot burner

P Pilot



Jacket installation (up to GSA-300)

1. Remove the proper knockout discs from panels as shown in Figure 4, page 7.
2. Follow Jacket Instructions in jacket carton.

Figure 9 Burner drawer installation

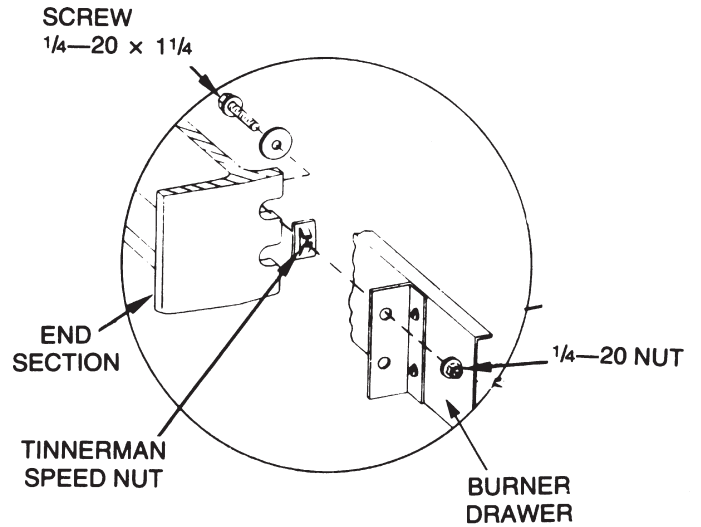
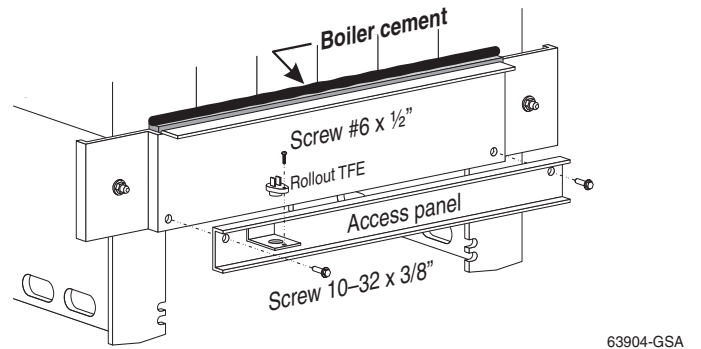

Figure 10 Access panel



Draft hood & spill switch

Draft hood installation

1. Secure draft hood to flue collector hood with sheet metal screws. See Figure 25, items 1 and 9, on page 38. Use boiler cement to provide gas tight seal.



Failure to maintain gas-tight seal can cause flue gas spillage and carbon monoxide emissions, resulting in severe personal injury or death.



Do not alter boiler draft hood or place any obstruction or non-approved vent damper in breaching or vent system. CSA certification will become void. Flue gas spillage and carbon monoxide emissions will occur causing severe personal injury or death.

Spill switch installation

1. Fasten spill switch to draft hood as shown in Figure 25, item 20, page 38.
2. See wiring diagram on Figure 20, page 18 to connect wires.

2 Prepare boiler continued

Install vent piping

1. Connect from draft hood or vent damper outlet to chimney or vent with same size vent connector.
2. Where possible, vertical venting to the outside from the draft hood or vent damper outlet will offer best performance.
3. Where horizontal vent connector is used, slope upward at least ¼" per lineal foot toward chimney or vent and support with hangers to prevent sagging.
4. Breeching must not be connected to any portion of a mechanical draft system that can operate under positive pressure.

WARNING Long horizontal vent connector, excessive number of elbow or tees, or other obstructions that restrict the flow of combustion gases should be avoided. Severe personal injury, death or substantial property damage could result.

Vent damper

NOTICE These systems are used on gas-fired boilers with vent dampers as shipped from factory. Boiler will not operate without vent damper installed.

Damper blade

See vent manufacturer's instructions to install plug (shipped with damper) in damper hole. Install plug with 3/8" diameter hole in vent damper hole.

Minimum clearances

Provide a minimum of 6" between the vent damper and any combustible material. (See "Minimum clearance to combustible materials," page 3, for minimum clearance from jacket top to ceiling to maintain this dimension).

Damper installation

DANGER Do not modify draft hood or vent damper, or make another connection between draft hood and vent damper or boiler except as noted below. This will void CSA certification and will not be covered by warranty. Any changes will cause severe personal injury, death or substantial property damage.

1. Install vent damper as shown in vent damper manufacturer's instructions. Vent damper must be installed so that it serves only one boiler and so damper blade indicator is visible to the user. See Figure 11.
2. Screws or rivets used to secure the vent damper to the draft hood must not interfere with rotation of the damper blade.
3. Install damper harness between damper actuator and knockout in jacket top panel. Use strain relief connectors and locknuts to secure both ends of damper harness.

CAUTION Keep wiring harness clear of all hot surfaces. Wire insulation could be damaged, causing risk of electrical short-circuit.

4. Read and apply the harness plug warning label (shown above) so that it is visible after installation.

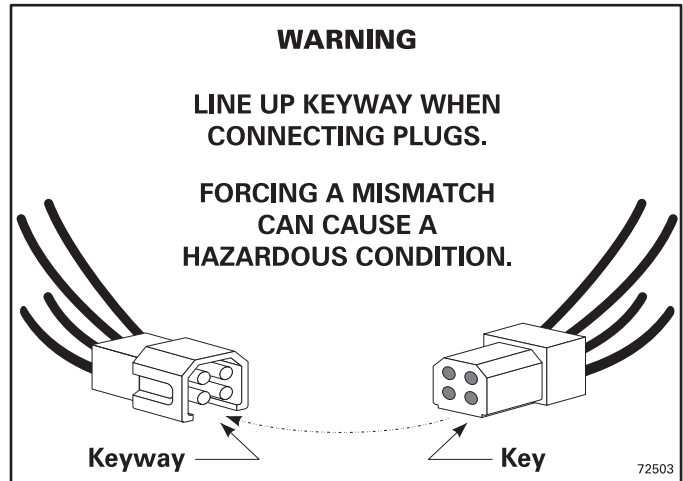

5. Plug damper harness receptacle into damper harness plug.

DANGER Bypassing (jumpering) vent damper will cause flue products such as carbon monoxide to escape into the house. This will cause severe personal injury or death.

CAUTION After boiler has operated once, if either end of harness is disconnected, the system safety shutdown will occur. The boiler will not operate until harness is reconnected.

NOTICE Effikal or Field Control dampers — Damper hold open switch must be in Automatic Operation position for system to operate properly.

Figure 11 Vent damper assemblies

Effikal or Field Control dampers

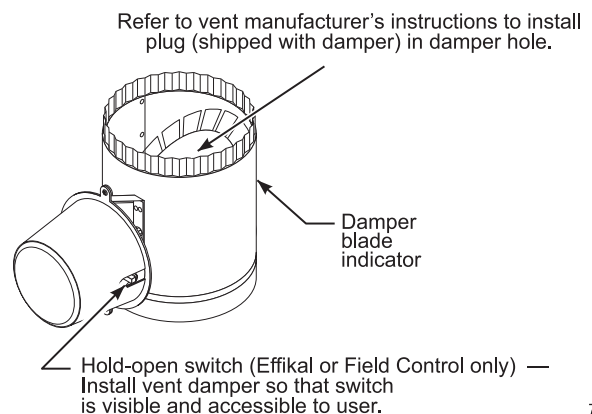

72519

3 Install piping

General

1. Pipe before installing controls. Connect return piping after jacket is attached. Connect supply piping before or after jacket is attached.

CAUTION Failure to properly pipe the boiler may result in improper operation and damage to the boiler or building.

2. See Figure 12 and Table 5. Pipe exactly as shown.
3. Satisfactory operation of a steam heating system depends on adequate condensate return to boiler to maintain a steady water level. Avoid adding raw makeup water. Where condensate return is not adequate, refer to recommendations on page 13.

Figure 12 Recommended piping, piping is for parallel-flow systems only. (see Table 5 for recommended sizing)

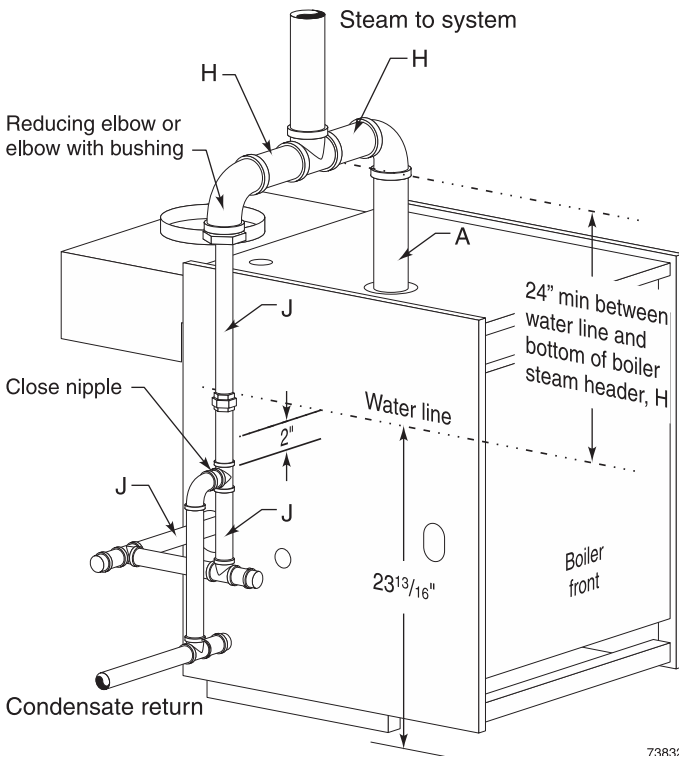

73R92

Connecting to counterflow piping

Apply the recommended piping in Figures 12 and 14 only when connecting to a parallel-flow system. When connecting to a counterflow system, the boiler steam supply must connect into the top of the counterflow system header, as shown in Figure 13.

Figure 13 Connection to counterflow steam piping (see Table 5 for recommended sizing)

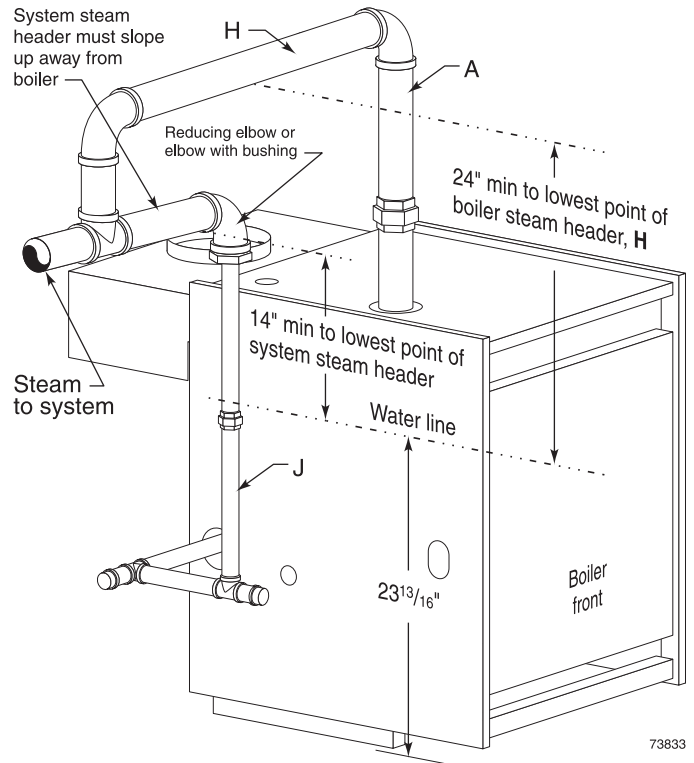

73833

Table 5 Recommended pipe sizing

Boiler model number	Riser (A)	Header (H) See Note	Equalizer (J)
GSA-075 and GSA-100	2"	2"	1 1/2"
GSA-125 through GSA-175	2 1/2"	2 1/2"	1 1/2"
GSA-200, GSA-250 & GSA-300	3"	3"	1 1/2"

Note: 24" minimum from waterline to bottom of header.

3 Install piping continued

Relief valve

Install relief valve in tapping on top of boiler. See Table 4, page 7, for control tapping locations. See the tag attached to the relief valve for manufacturer’s instructions.

WARNING Follow the steps below to avoid potential severe personal injury, death or substantial property damage.

- When installing the relief valve, ensure that all connections, including the valve inlet, are clean and free from any foreign matter.
- Mount the relief valve only in the vertical position, directly connected to the tapping designated in the manual on top of the boiler.
- Use pipe compound sparingly, or tape, on external threads only.
- Do not use a pipe wrench! Use proper type and size wrench on wrench pads only.

DANGER During operation, this valve may discharge large amounts of steam and/or hot water. Therefore, to reduce the potential for bodily injury and property damage, a discharge line MUST be installed that:

- Is connected from the outlet to a safe point of discharge with no intervening valve.
- Allows complete drainage of both the valve and the discharge line.
- Is independently supported and securely anchored so as to avoid applied stress as possible.
- Terminates freely to atmosphere where any discharge will be clearly visible and is at no risk of freezing.
- Is, over its entire length, of a pipe size equal to or greater than that of the valve outlet.

Use only schedule 40 metal pipe for discharge. (Do not use schedule 80, extra strong or double strong pipe or connections.)

DO NOT CAP, PLUG OR OTHERWISE OBSTRUCT DISCHARGE PIPE OUTLET! If discharge is piped upward, a condensate drain must be provided in the elbow below the vertical pipe to prevent condensate from returning into the valve. Failure to comply with these instructions will cause a dangerous spray of hot water and steam that would cause severe personal injury or death.

Table 6 Reservoir pipe sizing

Boiler model number	Max. boiler gross output	Time from initial steaming to average condensate return (boiler steaming capacity based on 970 Btu per pound of steam)					
		15 minutes		20 minutes		30 minutes	
		MBH	gallons	pipe length (feet)	gallons	pipe length (feet)	gallons
GSA-075/100	75	3/4	3/4	1 1/2	1 1/2	3	2 1/2
GSA-125/150	125	1 1/4	1 1/4	2 1/2	2 1/4	Use boiler feed system	
GSA-175	150	1 1/2	1 1/2	3	2 1/2		
GSA-200	175	1 3/4	1 3/4	Use boiler feed system			
GSA-250	225	2 1/2	2				
GSA-300	250	2 1/2	2 1/4				

Designed full capacity steaming time of modern boilers is 10 minutes.

Table 7 Boiler feed system sizing

Boiler model number	Gross output (pounds steam per hour)	Condensate (gallons per hour)	Minimum condensate receiver capacity gallons for boiler steaming times (minutes) of: (note 1)				Suggested feed pump capacity (GPM @ 15 PSI) (note 2)
			15 min.	30 min.	45 min.	60 min.	
GSA-075	63	8	2	4	6	8	0.2
GSA-100	81	10	3	6	9	12	0.3
GSA-125	102	12	4	7	11	14	0.4
GSA-150	122	15	5	9	14	18	0.5
GSA-175	142	17	5	10	15	20	0.6
GSA-200	163	20	6	12	18	24	0.7
GSA-250	203	24	7	14	22	29	0.8
GSA-300	240	29	9	17	26	36	1.0

NOTES:
 1. Maximum time to when condensate returns to boiler.
 2. If pump capacity exceeds capacity shown, pump can be throttled with globe or ball valve.

3 Install piping continued

Condensate return

Modern steam boilers are designed to steam for less time than older, larger boilers. When replacing an older steam boiler the system condensate return time may be longer than the steaming time. This could cause the following problems:

1. Boilers fitted with an automatic water feed could overflow.
2. Units fitted with only a low water cutoff would shut down and cycle while waiting for condensate to return.

Following is a simple method for determining whether or not a reservoir pipe is required to lengthen steaming time for a residential installation:

1. Disconnect condensate return line at existing boiler.
2. Heat boiler and allow to steam for 10 minutes. Turn off boiler.
3. Measure length of time from when boiler started to steam to when condensate begins to return through condensate line.
4. Measure length of time from when condensate begins to return to when it stops returning. Divide this time by 2.
5. Add time measured in step 3 to time calculated in step 4. This sum is the average time required for condensate to return to the boiler.
6. If this total time is 10 minutes or less, no reservoir pipe is needed.

If total time for condensate to return to boiler (from step 5) is more than 10 minutes, a reservoir pipe (or boiler feed system) is recommended. See Table 6, page 12, for suggested reservoir pipe size. Install as shown in Figure 14.

For larger systems (as noted in Table 6, page 12), use a boiler feed system with a condensate tank and feed pump. You will have to install a low water cutoff/pump control on the boiler to operate the pump. Use Table 7, page 12 to size boiler feed systems. See Table 4, page 7, for tapping locations. (The use of a combination condensate tank and float-controlled condensate return pump is not recommended.)

For most residential installations a reservoir pipe may be all that is necessary to ensure proper operation.

Figure 14 Recommended piping for parallel-flow systems with optional reservoir pipe

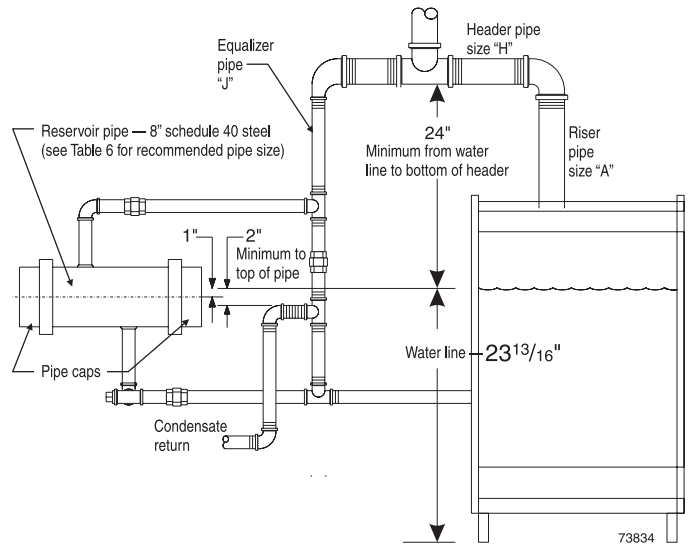

4 Install controls

Controls

WARNING Failure to properly install, pipe and wire boiler controls may result in severe damage to the boiler, building and personnel.

1. Controls are mounted and wired as shown in Figure 15. for actual tapping locations, see Table 4 and Figure 3 on page 7.
2. Bring supply wiring to boiler. Must be 14 gauge or heavier.
3. See wiring diagram, Figure 20, page 18.

Figure 15 Controls

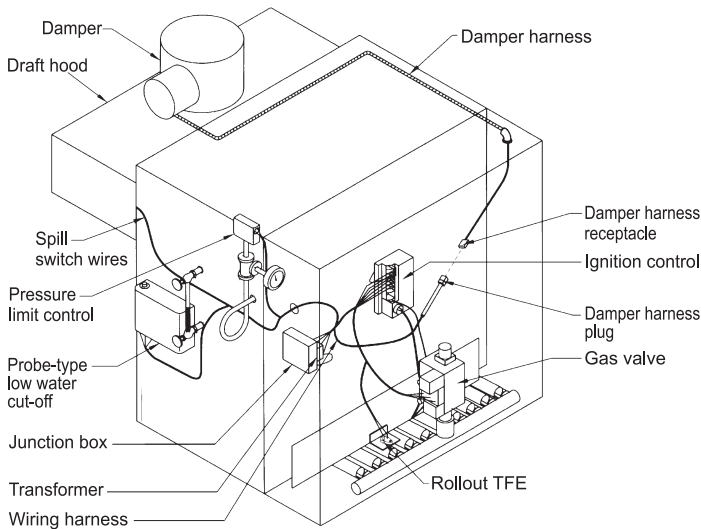

Float-type low water cutoff (when provided by others)

1. Install low water cutoff as shown in Figure 16, below. See Table 4 and Figure 3 on page 7 for actual tapping location.
2. Install blowdown line in bottom of cutoff. See control manufacturer's instructions for details.

WARNING Pipe blowdown line near floor close to floor drain to eliminate potential of severe burns. Do not plug, valve or place any obstruction in blowdown line.

3. Water feeders are not recommended for primary control. A low water cutoff with pump controller is recommended with a condensate receiver and feed pump.

Figure 16 Float-type low water cutoff (when provided by others)

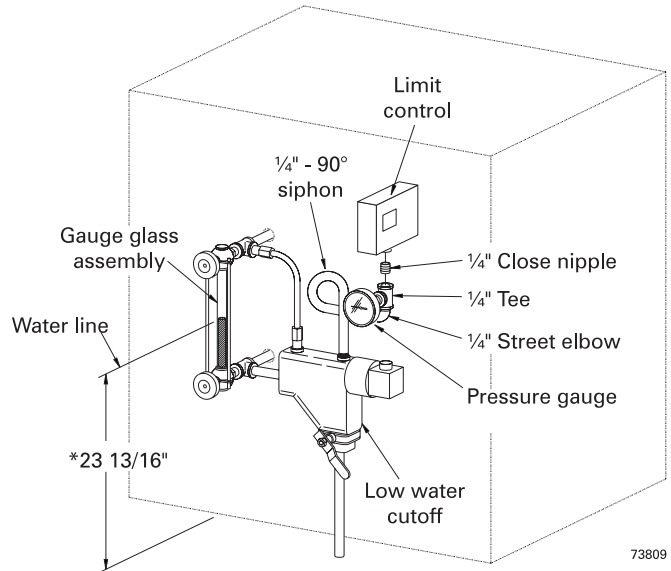

* Water line dimension measured from bottom of boiler section leg where it rests on the boiler room floor or boiler foundation.

5 Install gas piping

Connecting gas supply piping to boiler

1. Remove jacket front panel and see Figure 17 to pipe gas to boiler.
 - a. Install drip leg at inlet of gas connection to boiler. Where local utility requires drip leg to be extended to the floor, use appropriate length of nipple between cap and tee.
 - b. Install ground joint union for servicing, when required.
 - c. Install manual shutoff valve in gas supply piping outside boiler jacket when required by local codes or utility requirements.
2. Support piping with hangers, not by boiler or its accessories.
3. Purge all air from gas supply piping.
4. Before placing boiler in operation, check boiler and its gas connection for leaks.
 - a. Close manual main shutoff valve during any pressure testing at less than 13" w.c.
 - b. Disconnect boiler and gas valve from gas supply piping during any pressure testing greater than 13" w.c.

⚠ WARNING Do not check for gas leaks with an open flame — Use bubble test. Failure to use bubble test or check for gas leaks can cause severe personal injury, death or substantial property damage.

5. Apply pipe sealant sparingly only to male threads of pipe joints so that pipe sealant does not block gas flow.

⚠ WARNING Failure to apply pipe sealant as described in this manual can result in severe personal injury, death or substantial property damage.

Natural Gas:

1. See Table 8 for pipe length and diameter. Base on rated boiler input, found on page 43 (divide by 1,000 to obtain cubic feet per hour). Table 8 is only for gas with specific gravity 0.60, with a pressure drop through the gas piping of 0.30" w.c. For additional gas pipe sizing information, see ANSI Z223.1 – latest edition.
2. Inlet pressure required at gas valve inlet:
 - Maximum: 13" w.c.
 - Minimum: 5" w.c.
 - Manifold gas pressure: 3.5" w.c.
3. Install 100% lockup gas pressure regulator in supply line if inlet pressure exceeds 13" w.c. Adjust for 13" w.c. maximum.

Table 8 Pipe capacity for 0.60 specific gravity natural gas

Gas pipe length (feet)	Capacity of pipe for pipe size of: (Capacity in cubic feet gas per hour)					
	1/2"	3/4"	1"	1 1/4"	1 1/2"	2"
10	132	278	520	1050	1600	3050
20	92	190	350	730	1100	2100
30	73	152	285	590	860	1650
40	63	130	245	500	760	1450
50	56	115	215	440	670	1270
75	45	93	175	360	545	1020
100	38	79	150	305	460	870
150	31	64	120	250	380	710

Figure 17 Gas supply piping

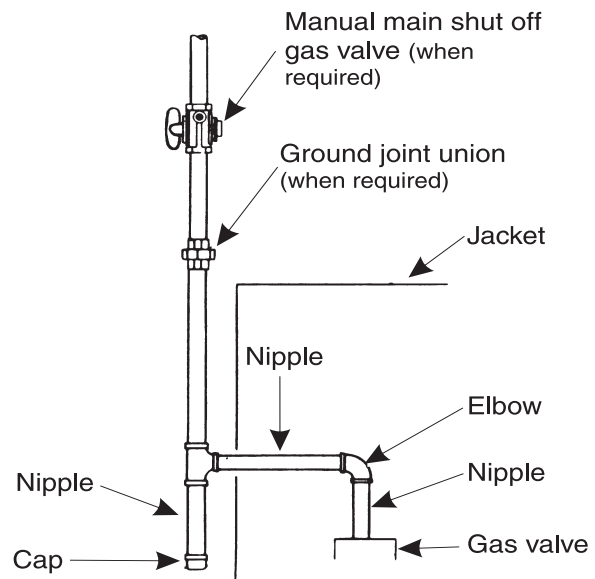

6 Field wiring

WARNING For your safety, turn off electrical power supply at service entrance panel before making any electrical connections to avoid possible electric shock hazard. Failure to do so can cause severe personal injury or death.

NOTICE Wiring must be N.E.C. Class 1. If rollout thermal fuse element wire supplied with boiler must be replaced, type 200°C wire or equivalent must be used. If other original wiring supplied with boiler must be replaced, use only type 105°C wire or equivalent.

Boiler must be electrically grounded as required by National Electrical Code ANSI/NFPA 70 – latest edition.

Electrical installation must comply with:

National Electrical Code ANSI/NFPA 70 – latest edition, and any other national, state, provincial or local codes or regulations.

Wiring connections

Boiler is shipped with controls completely wired, except spill switch and vent damper. See wiring diagram, Figure 20, page 18.

Thermostat

1. Connect thermostat as shown on wiring diagram on boiler.
2. Install on inside wall away from influences of drafts, hot or cold water pipes, lighting fixtures, television, sunrays or fireplaces.
3. If thermostat has a heat anticipator, set heat anticipator in thermostat to match power requirements of equipment connected to it. See boiler wiring diagram (on boiler, or Figure 20, page 18 for recommended setting. For other devices, see manufacturer's specifications. Wiring diagram on boiler gives setting for control module and gas valve. Also see instructions with thermostat.

Junction box

Connect 120VAC power wiring (Figure 18). A separate electrical circuit with a fused disconnect switch (15 amp. recommended) should be used for the boiler.

Figure 18 Field wiring connections — service switch and thermostat (or end switch) provided by installer

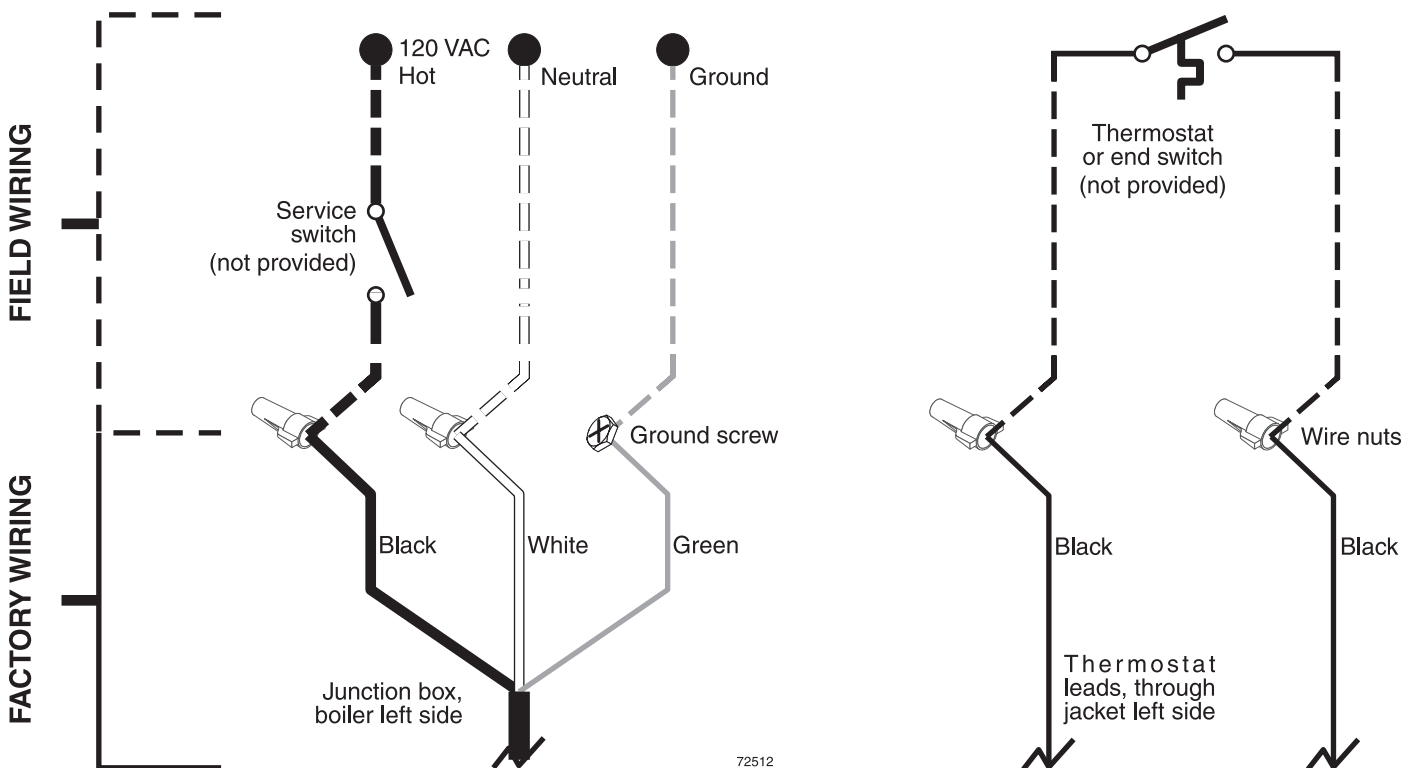

6 Field wiring continued

GSA boilers with probe LWCO

Controls and wiring

Controls — with probe LWCO

1. Controls are mounted and wired as shown in Figure 19.
2. For actual tapping locations, refer to Figure 3, page 7.
3. See Figure 20, page 18 for wiring diagram.

Install vent damper

See “Vent damper”, page 10 and Figure 19 to install and connect the vent damper.

Field wiring connections

1. Refer to page 16 for field wiring connections.
2. Use minimum 14 gauge wire for line voltage supply wiring to the boiler.

Figure 19 GSA boiler with probe low water cut-off — control locations

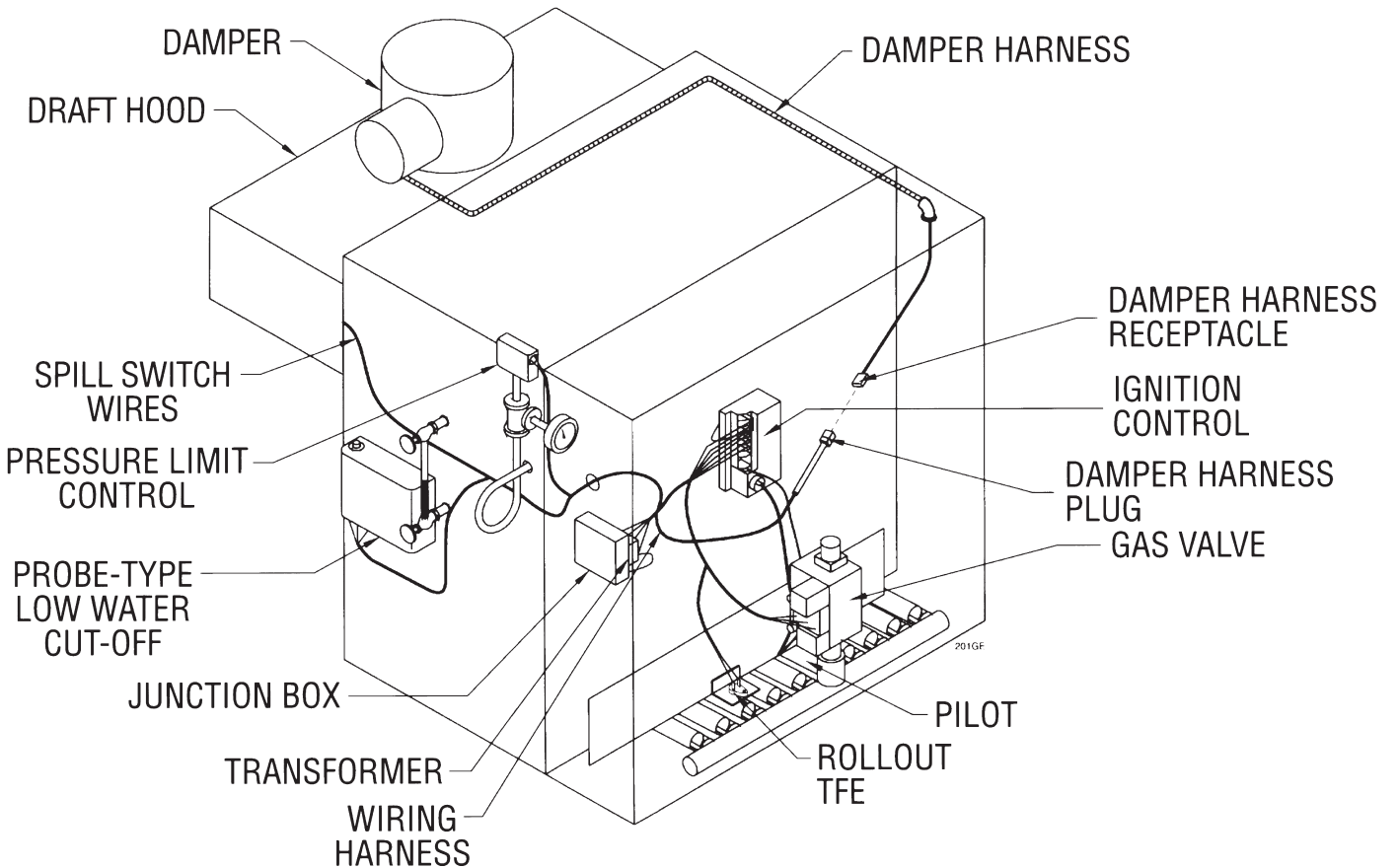
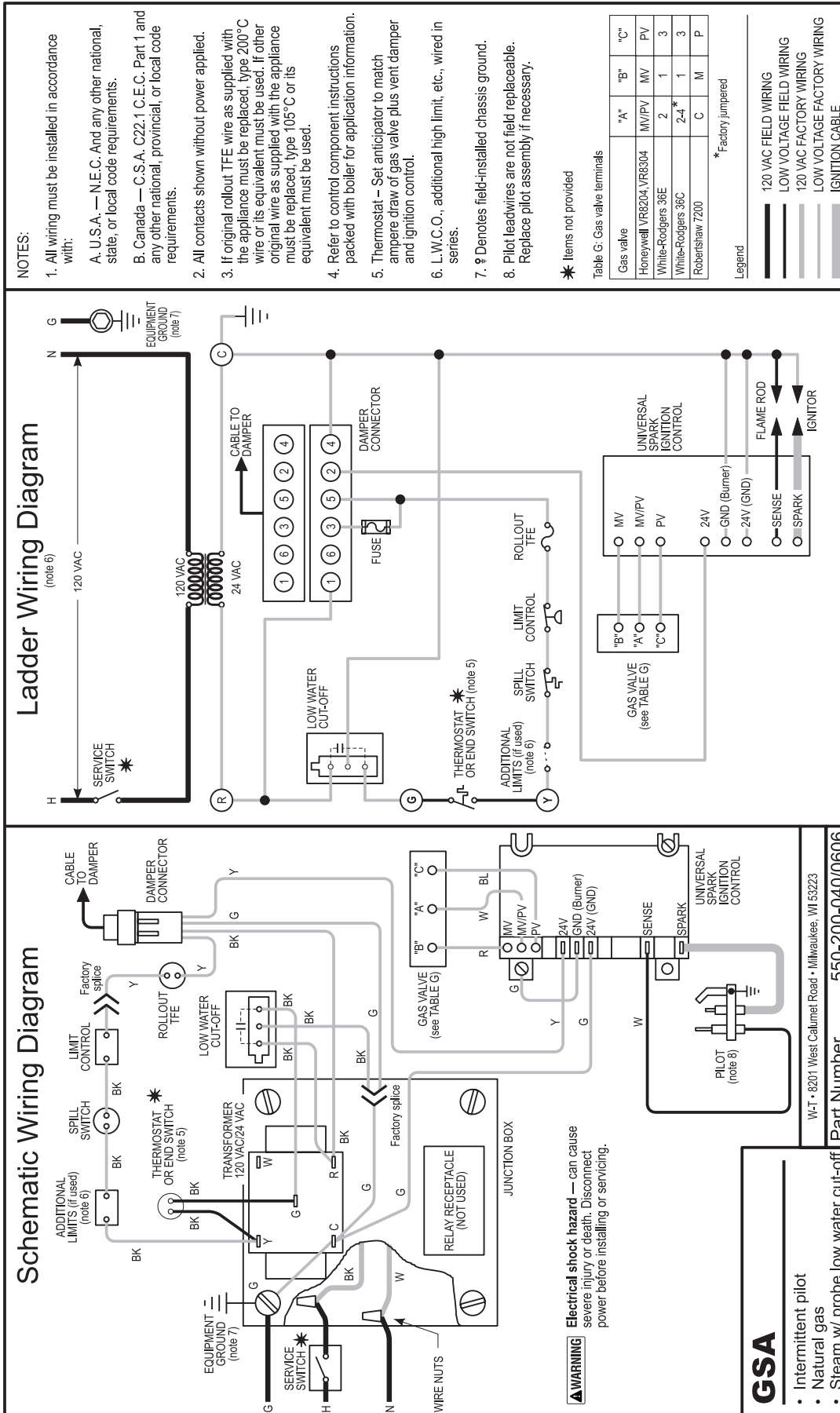

Figure 20 Wiring diagrams – GSA spark ignition boilers (with probe LWCO)



7 Start-up

Preparation

Check for gas leaks

WARNING Before starting the boiler, and during initial operation, smell near the floor and around the boiler for gas odorant or any unusual odor. Do not proceed with start-up if there is any indication of a gas leak. Repair any leak at once.

Determine if water treatment is needed

DANGER Do not use petroleum-based cleaning or sealing compounds in boiler system. Severe damage to boiler will occur, resulting in substantial property damage.

WARNING Eliminate all system leaks. Continual fresh makeup water will reduce boiler life. Minerals can build up in sections, reducing heat transfer, overheating cast iron, and causing section failure.

Consult local water treatment companies for unusually hard water areas (above 7 grains hardness) or low pH water conditions (below 7.0). Boiler water pH of 7.0 to 8.5 is recommended.

Fill the system with water

1. Do not fill (except for leakage tests) until boiler is ready to be fired.
2. Fill to normal waterline, halfway up gauge glass.
3. Boiler water pH 7.0 to 8.5 is recommended.
4. Follow skimming procedure, right.

Skimming the boiler

NOTICE Clean all newly installed steam boilers to remove oil and grease. Failure to properly clean can result in violent fluctuations of water level, water passing into steam mains or high maintenance costs on strainers, traps and vents.

DANGER Do not use petroleum-based cleaning or sealing compounds in boiler system. Severe damage to boiler will occur, resulting in substantial property damage.

1. Provide 1½” piping from skim tapping to floor drain.
2. Adjust waterline to midpoint of skim tapping. See Figure 3, page 7.
3. Follow the appropriate Operating Instructions starting on page 23, to fire the boiler to maintain temperature below steaming rate.
4. Feed in water to maintain water level. Cycle burners to prevent rise in steam pressure.
5. Continue skimming until discharge is clear. May take several hours.
6. Drain boiler. While boiler is **warm, but not hot**, flush all interior surfaces under full pressure until drain water runs clear.
7. Remove skim piping. Plug tapping.
8. Close drain cock. Fill with fresh water to waterline. Start burners and steam for 15 minutes to remove dissolved gases. Stop burners.
9. Check traps and air vents for proper operation.
10. Process may need to be repeated after several weeks of operation.

Inspect base insulation

WARNING The boiler contains ceramic fiber and fiberglass materials. Use care when handling these materials per instructions on page 22 of this manual. Failure to comply could result in severe personal injury.

Check to make sure insulation is secure against all four sides of the base. If insulation is damaged or displaced, do not operate boiler. Replace or reposition insulation.

WARNING Failure to replace damaged insulation or reposition insulation can result in a fire hazard, causing severe personal injury, death or substantial property damage.

7 Start-up continued

Operate the boiler

⚠ WARNING DO NOT proceed with boiler operation unless boiler and system have been filled with water and all instructions and procedures of previous manual sections have been completed. Failure to do so could result in severe personal injury, death or substantial property damage. Before starting the boiler . . .

- Spark ignition boilers: See Operating Label Instructions starting on page 24.
- Verify the boiler and system water level is correct (no more than ½ of gauge glass or less than ¼” above bottom of gauge glass).
- Verify the “Preparation” procedures, on previous page, have been completed.

Start the boiler

1. Check boiler water level — Should be approximately ½ way up gauge glass.
2. Remove boiler jacket door and note the gas valve manufacturer and model number.
3. Follow the appropriate Operating Instructions starting on page 24. (The Operating Instruction label on the boiler provides the same information.)
4. If boiler fails to start, see “If boiler doesn’t start . . . Check for:” on this page.

Check system and boiler

⚠ WARNING Eliminate all system leaks. Continual fresh makeup water will reduce boiler life. Minerals can build up in sections, reducing heat transfer, overheating cast iron, and causing section failure.

⚠ WARNING If you discover evidence of any gas leak, shut down the boiler at once. Find the leak source with bubble test and repair immediately. Do not start boiler again until corrected. Failure to comply could result in severe personal injury, death or substantial property damage.

⚠ DANGER Do not use petroleum-based cleaning or sealing compounds in boiler system. Severe damage to boiler will occur, resulting in substantial property damage.

1. Check system piping for leaks. If found, shut down boiler and repair immediately.
2. Inspect vent system thoroughly for signs of deterioration from corrosion, physical damage or sagging. Verify that masonry chimney liners are in good condition, with no obstructions, and there are no openings into the chimney.
3. Check around the boiler for gas odor following the procedure of “Check for gas leaks”, page 17.
4. Verify operation using procedures below. Perform “Check-out procedure”, page 28, and fill in the “Installation and service certificate”.

If boiler doesn’t start . . . Check for:

1. Loose connections, blown fuse or service switch off?
2. High limit switch set below boiler pressure?
3. Thermostat set below room temperature?
4. Gas not turned on at meter or boiler?
5. Incoming gas pressure less than:
5” w.c. for natural gas?
6. If none of the above corrects the problem, see “Troubleshooting”, starting on page 33 .

7 Start-up continued

Verify operation

Check burner flame — Pilot burner

Proper pilot flame (see Figure 21):

1. Blue flame.
2. Inner cone engulfing flame rod.
3. Flame rod glowing cherry red.

Improper pilot flame:

1. Overfired — Large flame lifting or blowing past flame rod.
2. Underfired — Small flame. Inner cone not engulfing flame rod.
3. Lack of primary air — Yellow flame tip.
4. Incorrectly heated flame rod.

Check burner flame — Main burner

Proper main burner flame (see Figure 22):

1. Yellow-orange streaks may appear (caused by dust).

Improper main burner flame:

1. Overfired — Large flames.
2. Underfired — Small flames.
3. Lack of primary air — Yellow tipping on flames (sooting will occur).

Figure 21 Typical pilot burner flame

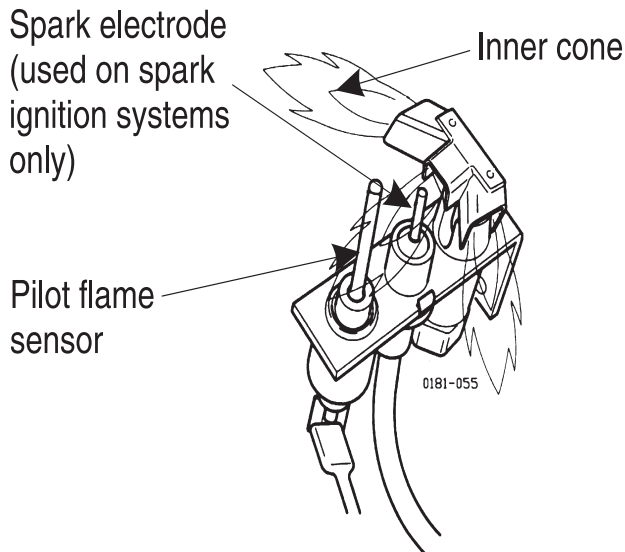
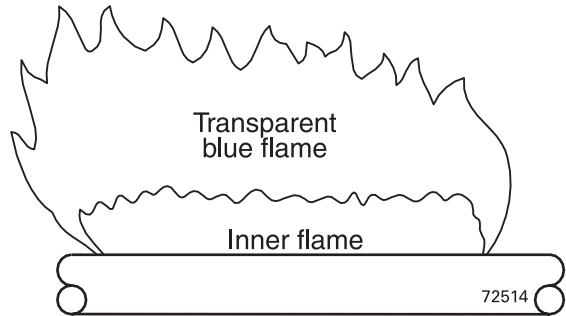

Figure 22 Typical main burner flame



Check vent damper operation

1. Raise room thermostat to call for heat — Vent damper actuator will slowly open vent damper.
2. When vent damper is fully open — Main gas valve will open and main burners will ignite.

⚠ DANGER Vent damper must be fully open before main burners light. If vent damper does not fully open, flue products such as carbon monoxide will escape into house, causing severe personal injury or death.

3. Lower thermostat setting — Main burner flames will go out, then vent damper will close.
4. Repeat Steps 1 through 3 several times to verify operation.
5. Return thermostat to normal setting.
6. Set thermostat heat anticipator setting indicated on wiring diagram.

Check venting system operation

With boiler firing, hold a candle or match below lower edge of draft hood “skirt.” If flame does not blow out, but burns undisturbed, the vent system is working properly. If flame blows out or flickers severely, the vent system must be checked for obstructions or other causes of improper venting.

Handling ceramic fiber and fiberglass materials

REMOVAL OF COMBUSTION CHAMBER LINING OR BASE PANELS

⚠ WARNING The combustion chamber lining or base insulation panels in this product contain ceramic fiber materials that have been identified as carcinogenic, or possibly carcinogenic, to humans. Ceramic fibers can be converted to cristobalite in very high temperature applications. The International Agency for Research on Cancer (IARC) has concluded, “Crystalline silica inhaled in the form of quartz or cristobalite from occupational sources is carcinogenic to humans (Group 1).”:

Precautionary measures

- Avoid breathing fiberglass dust and contact with skin or eyes.
 - Use NIOSH certified dust respirator (N95). This type of respirator is based on the OSHA requirements for fiberglass wool at the time this document was written. Other types of respirators may be needed depending on the job site conditions. Current NIOSH recommendations can be found on the NIOSH web site at <http://www.cdc.gov/niosh/homepage.html>. NIOSH approved respirators, manufacturers, and phone numbers are also listed on this web site.
 - Wear long-sleeved, loose fitting clothing, gloves, and eye protection.
- Apply enough water to the combustion chamber lining or base insulation to prevent airborne dust.
- Remove combustion chamber lining or base insulation from the boiler and place it in a plastic bag for disposal.
- Wash potentially contaminated clothes separately from other clothing. Rinse clothes washer thoroughly.

NIOSH stated First Aid.

- Eye: Irrigate immediately.
- Breathing: Fresh air.

REMOVAL OF FIBERGLASS WOOL – OR – INSTALLATION OF FIBERGLASS WOOL, COMBUSTION CHAMBER LINING OR BASE PANELS:

⚠ WARNING This product contains fiberglass jacket insulation and ceramic fiber materials in combustion chamber lining or base panels in gas fired products. Airborne fibers from these materials have been listed by the State of California as a possible cause of cancer through inhalation.

Precautionary measures

- Avoid breathing fiberglass dust and contact with skin or eyes.
 - Use NIOSH certified dust respirator (N95). This type of respirator is based on the OSHA requirements for fiberglass wool at the time this document was written. Other types of respirators may be needed depending on the job site conditions. Current NIOSH recommendations can be found on the NIOSH web site at <http://www.cdc.gov/niosh/homepage.html>. NIOSH approved respirators, manufacturers, and phone numbers are also listed on this web site.
 - Wear long-sleeved, loose fitting clothing, gloves, and eye protection.
- Operations such as sawing, blowing, tear out, and spraying may generate airborne fiber concentration requiring additional protection.
- Wash potentially contaminated clothes separately from other clothing. Rinse clothes washer thoroughly.

NIOSH stated First Aid.

- Eye: Irrigate immediately.
- Breathing: Fresh air.

8 Operation

Operating the boiler

Follow Boiler Manual

Follow all installation, start-up instructions and system check-out. Follow the Start-up section and Checkout Procedure on page 28 before proceeding with boiler operation.

Operating Instructions

1. Identify the gas valve used on the boiler.
2. Select the correct lighting instruction procedure:

Gas Valve	Follow:
• Honeywell VR8204/VR8304	Page 24
• White-Rodgers 36E	Page 25
• Robertshaw 7200	Page 26
• White-Rodgers 36C	Page 27
3. Mark the correct Operating Instructions in the User's Information Manual so the owner will know which applies.
4. Follow the Operating Instructions selected to operate the boiler.

Verify the sequence of operation

1. Raise the thermostat to call for heat. The vent damper actuator will slowly open the damper.
2. When the vent damper is fully open, the ignition control powers the pilot spark generator and opens the pilot valve.

⚠ DANGER The vent damper must be in the open position when the main burners are operating. If the damper is not in the open position, flue products will escape into the building, causing severe personal injury or death.

3. The pilot should light:
 - a. If the pilot does not light within 15 seconds, the pilot valve will close and the spark generator is turned off. The ignition control initiates a five-minute wait period. If the call for heat continues after five minutes, the ignition sequence starts again at step 2.
 - b. If the pilot lights and the ignition control senses flame current, the main gas valve opens and the spark generator is turned off. The main burners will light.
4. During main burner operation:
 - a. The ignition control monitors pilot flame current. If flame signal is lost, the main valve is closed, the spark generator is activated, and sequence returns to step 3.
 - b. If power is interrupted, the ignition control turns off pilot and main gas valves. The sequence returns to step 1 when power is restored.
5. When the thermostat is satisfied, the pilot and main gas valves are closed. The vent damper will close.
6. The boiler is now in the off cycle.
7. Repeat steps 1 through 6 above several times to verify operation.
8. Return the thermostat to its normal setting.

Set the thermostat anticipator

1. The thermostat anticipator must be set to match the operating ampere load for best operation.
2. Find the correct setting from Figure 23. Add the total amperes for the gas valve, ignition control and vent damper.

Figure 23 Thermostat anticipator setting — set to equal the total current of the gas valve, ignition control and vent damper used on the boiler.

Device		Amps
Gas valves	Honeywell VR8204	0.5
	Honeywell VR8304	0.7
	White-Rodgers 36E	0.3
	White-Rodgers 36C	0.6
	Robertshaw 7200	0.4
Ignition controls	Honeywell S8620C	0.2
	United Technologies 1003	0.1
Vent dampers	Effikal	0.2
	Field Controls	0.1

Verify proper operation after servicing

Follow the instructions “Start-up” starting on page 19 to verify proper operation after servicing the boiler or replacing components.

Operating Instructions

Spark ignition

Gas valve – Honeywell VR8204/VR8304

FOR YOUR SAFETY READ BEFORE OPERATING



WARNING If you do not follow these instructions exactly, a fire or explosion may result causing property damage, personal injury or loss of life.

- A. This appliance is equipped with an ignition device which automatically lights the pilot. Do not try to light the pilot by hand.
- B. BEFORE OPERATING, smell all around the appliance area for gas. Be sure to smell next to the floor because some gas is heavier than air and will settle on the floor. See below.
- C. Use only your hand to turn the gas control knob. Never use tools. If the knob will not turn by hand, don't try to repair it, call a qualified service technician. Force or attempted repair may result in a fire or explosion.
- D. Do not use this appliance if any part has been under water. Immediately call a qualified service technician to inspect the appliance and to replace any part of the control system and any gas control, which has been under water.

WHAT TO DO IF YOU SMELL GAS

- Do not try to light any appliance.
- Do not touch any electric switch; do not use any phone in your building.
- Immediately call your gas supplier from a neighbor's phone. Follow the gas supplier's instructions.
- If you cannot reach your gas supplier, call the fire department.

OPERATING INSTRUCTIONS

1. STOP! Read the safety information above on this label.
2. Set the thermostat to lowest setting.
3. Turn off all electrical power to the appliance.
4. Remove front panel.
5. This appliance is equipped with an ignition device which automatically lights the pilot. Do not try to light the pilot by hand.
6. Turn gas control knob clockwise ↻ to "OFF."
7. Wait five (5) minutes to clear out any gas. Then smell for gas, including near the floor. If you smell gas, STOP! Follow "B" in the safety information above. If you don't smell gas, go to the next step.
8. Turn gas control knob counterclockwise ↻ to "ON."
9. Turn on all electric power to the appliance.
10. Set thermostat to desired setting.
11. If the appliance will not operate, follow the instructions "To Turn Off Gas To The Appliance" and call your service technician or gas supplier.
12. Replace front panel.

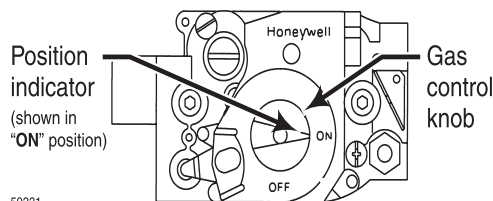

TO TURN OFF GAS TO THE APPLIANCE

1. Set the thermostat to lowest setting.
2. Turn off all electric power to the appliance if service is to be performed.
3. Remove front panel.
4. Turn gas control knob clockwise ↻ to "OFF." Do not force.
5. Replace front panel.

550-223-041(0415)

Operating Instructions

Spark ignition

Gas valve – White-Rodgers 36E

FOR YOUR SAFETY READ BEFORE OPERATING

WARNING If you do not follow these instructions exactly, a fire or explosion may result causing property damage, personal injury or loss of life.

- A. This appliance is equipped with an ignition device which automatically lights the pilot. Do not try to light the pilot by hand.
- B. BEFORE OPERATING, smell all around the appliance area for gas. Be sure to smell next to the floor because some gas is heavier than air and will settle on the floor. See below.
- C. Use only your hand to turn the gas control knob. Never use tools. If the knob will not turn by hand, don't try to repair it, call a qualified service technician. Force or attempted repair may result in a fire or explosion.
- D. Do not use this appliance if any part has been under water. Immediately call a qualified service technician to inspect the appliance and to replace any part of the control system and any gas control, which has been under water.

WHAT TO DO IF YOU SMELL GAS

- Do not try to light any appliance.
- Do not touch any electric switch; do not use any phone in your building.
- Immediately call your gas supplier from a neighbor's phone. Follow the gas supplier's instructions.
- If you cannot reach your gas supplier, call the fire department.

OPERATING INSTRUCTIONS

1. STOP! Read the safety information above on this label.
2. Set the thermostat to lowest setting.
3. Turn off all electrical power to the appliance.
4. Remove front panel.
5. This appliance is equipped with an ignition device which automatically lights the pilot. Do not try to light the pilot by hand.
6. Turn gas control knob clockwise ↻ to "OFF."
7. Wait five (5) minutes to clear out any gas. Then smell for gas, including near the floor. If you smell gas, STOP! Follow "B" in the safety information above. If you don't smell gas, go to the next step.
8. Turn gas control knob counterclockwise ↺ to "ON."
9. Turn on all electric power to the appliance.
10. Set thermostat to desired setting.
11. If the appliance will not operate, follow the instructions "To Turn Off Gas To The Appliance" and call your service technician or gas supplier.
12. Replace front panel.

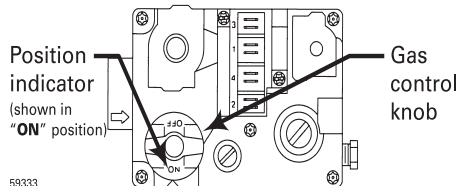

TO TURN OFF GAS TO THE APPLIANCE

1. Set the thermostat to lowest setting.
2. Turn off all electric power to the appliance if service is to be performed.
3. Remove front panel.
4. Turn gas control knob clockwise ↻ to "OFF." Do not force.
5. Replace front panel.

550-223-042(0906)

Operating Instructions

Spark ignition

Gas valve – Robertshaw 7200

FOR YOUR SAFETY READ BEFORE OPERATING

WARNING If you do not follow these instructions exactly, a fire or explosion may result causing property damage, personal injury or loss of life.

- A. This appliance is equipped with an ignition device which automatically lights the pilot. Do not try to light the pilot by hand.
- B. **BEFORE OPERATING**, smell all around the appliance area for gas. Be sure to smell next to the floor because some gas is heavier than air and will settle on the floor. See below.
- C. Use only your hand to depress or move the selector arm. Never use tools. If the selector arm will not depress or move by hand, don't try to repair it, call a qualified service technician. Force or attempted repair may result in a fire or explosion.
- D. Do not use this appliance if any part has been under water. Immediately call a qualified service technician to inspect the appliance and to replace any part of the control system and any gas control, which has been under water.

WHAT TO DO IF YOU SMELL GAS

- Do not try to light any appliance.
- Do not touch any electric switch; do not use any phone in your building.
- Immediately call your gas supplier from a neighbor's phone. Follow the gas supplier's instructions.
- If you cannot reach your gas supplier, call the fire department.

OPERATING INSTRUCTIONS

1. **STOP!** Read the safety information above on this label.
2. Set the thermostat to lowest setting.
3. Turn off all electrical power to the appliance.
4. Remove front panel.
5. This appliance is equipped with an ignition device which automatically lights the pilot. Do not try to light the pilot by hand.
6. Depress and move selector arm left ↶ to "OFF." Note: Selector arm cannot be moved to "OFF" unless selector arm is depressed slightly. Do not force.
7. Wait five (5) minutes to clear out any gas. Then smell for gas, including near the floor. If you smell gas, **STOP!** Follow "B" in the safety information above. If you don't smell gas, go to the next step.
8. Move selector arm right ↷ to "ON."
9. Turn on all electric power to the appliance.
10. Set thermostat to desired setting.
11. If the appliance will not operate, follow the instructions "To Turn Off Gas To The Appliance" and call your service technician or gas supplier.
12. Replace front panel.

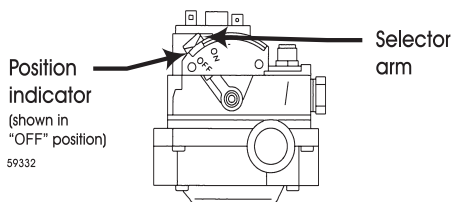

TO TURN OFF GAS TO THE APPLIANCE

1. Set the thermostat to lowest setting.
2. Turn off all electric power to the appliance if service is to be performed.
3. Remove front panel.
4. Depress and move selector arm to "OFF." Do not force.
5. Replace front panel.

550-223-044(0511)

Operating Instructions

Spark ignition

Gas valve – White-Rodgers 36C

FOR YOUR SAFETY READ BEFORE OPERATING

WARNING If you do not follow these instructions exactly, a fire or explosion may result causing property damage, personal injury or loss of life.

- A. This appliance is equipped with an ignition device which automatically lights the pilot. Do not try to light the pilot by hand.
- B. BEFORE OPERATING, smell all around the appliance area for gas. Be sure to smell next to the floor because some gas is heavier than air and will settle on the floor. See below.
- C. Use only your hand to depress or turn the gas control knob. Never use tools. If the knob will not depress or turn by hand, don't try to repair it, call a qualified service technician. Force or attempted repair may result in a fire or explosion.
- D. Do not use this appliance if any part has been under water. Immediately call a qualified service technician to inspect the appliance and to replace any part of the control system and any gas control, which has been under water.

WHAT TO DO IF YOU SMELL GAS

- Do not try to light any appliance.
- Do not touch any electric switch; do not use any phone in your building.
- Immediately call your gas supplier from a neighbor's phone. Follow the gas supplier's instructions.
- If you cannot reach your gas supplier, call the fire department.

OPERATING INSTRUCTIONS

1. STOP! Read the safety information above on this label.
2. Set the thermostat to lowest setting.
3. Turn off all electrical power to the appliance.
4. Remove front panel.
5. This appliance is equipped with an ignition device which automatically lights the pilot. Do not try to light the pilot by hand.
6. Depress gas control knob slightly and turn clockwise ↻ to "OFF." Note: Knob cannot be turned to "OFF" unless knob is depressed slightly. Do not force.
7. Wait five (5) minutes to clear out any gas. Then smell for gas, including near the floor. If you smell gas, STOP! Follow "B" in the safety information above. If you don't smell gas, go to the next step.
8. Turn gas control knob counterclockwise ↶ to "ON."
9. Turn on all electric power to the appliance.
10. Set thermostat to desired setting.
11. If the appliance will not operate, follow the instructions "To Turn Off Gas To The Appliance" and call your service technician or gas supplier.
12. Replace front panel.

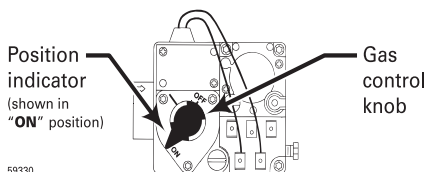

TO TURN OFF GAS TO THE APPLIANCE

1. Set the thermostat to lowest setting.
2. Turn off all electric power to the appliance if service is to be performed.
3. Remove front panel.
4. Depress gas control knob slightly and turn clockwise ↻ to "OFF." Do not force.
5. Replace front panel.

550-223-043(0906)

9 Checkout procedure

- Boiler and heat distribution units filled with water?
- Boilers properly skimmed?
- Air purged from gas piping? Piping checked for leaks?
- Correctly-sized manifold orifices installed? See Table 3, page 7, to check size and fuel type.

▲ DANGER Correctly sized manifold orifices must be used. Failure to do so will cause severe personal injury, death or substantial property damage.

- Button on spill switch pushed in?
- Follow the Operating Instructions starting on page 24 for proper start-up?
- Proper burner flame observed? See “Verify operation,” page 21.
- Test limit control – While burners are operating, move indicator on limit control below actual boiler pressure. Burners should go off. Raise setting on limit control above boiler pressure and burners should reignite.
- Test low water cutoff – Check probe-type low water cutoff for proper operation.
 - a. Turn off power to boiler and wait 5 minutes.
 - b. Drain water to bottom of gauge glass.
 - c. Turn on power.
 - d. Set thermostat to call for heat. Red neon lamp on lower water cutoff should light.
 - e. Wait 5 minutes. Boiler should not fire.
 - f. Refill boiler to correct water line. Red lamp should go off.
 - g. Wait 5 minutes. Boiler should fire.
 - h. Return thermostat to normal setting.
- Test additional field-installed controls – If boiler has an additional high limit, low water cutoff or other controls, test for operation as outlined by manufacturer. Burners should be operating and should go off when controls are tested. When controls are restored, burners should reignite.
- Test ignition system safety device –

Spark ignition boilers: Connect manometer to outlet side of gas valve. Start boiler, allowing for normal start-up cycle to occur and main burners to ignite. With main burners on, manually shut off gas supply at manual main shutoff gas valve. Burners should go off. Open manual main shut-off gas valve. Manometer should confirm there is no gas flow. Pilot will relight, flame sensing element will sense pilot flame and main burners reignite. Put boiler back into operation.

- Set limit control(s) to system pressure requirements. Adjust balancing valves and controls to provide design pressure to system.
- Verify thermostat heat anticipator (if available) set properly? See “Thermostat”, page 16.
- Cycle boiler with thermostat – Raise to highest setting and verify boiler goes through normal start-up cycle. Lower to lowest setting and verify boiler goes off.
- Measure natural gas input:
 - a. Operate boiler 10 minutes.
 - b. Turn off other appliances.
 - c. At natural gas meter, measure time (in seconds) required to use one cubic foot of gas.
 - d. Calculate gas input:

$$\frac{3600 \times 1000}{\text{number of seconds from step c}} = \text{Btuh}$$
 - e. Btuh calculated should approximate input rating on boiler rating label.
- Check manifold gas pressure by connecting manometer to downstream test tapping on main gas valve. Manifold pressure for natural gas should be 3.5” w.c.
- Observe several operating cycles for proper operation.
- Set room thermostat to desired room temperature.
- Fill in “Installation and service certificate” below?
- Review all instructions shipped with this boiler with owner or maintenance person. Return instructions to envelope and give to owner or place in pocket inside front panel in boiler.

Installation and Service Certificate

Boiler model _____ Series _____ Consumer Protection number _____ Date installed _____

Measured Btuh input _____

- Installation instructions have been followed.
- Check-out sequence has been performed.
- Above information is certified to be correct.
- Information received and left with owner/maintenance person.

Installer _____
(company)

_____ (address)

_____ (phone)

(installer’s signature)

10 Service and maintenance

Table 9 Service and maintenance schedules (service technician and owner)

Service technician (see following pages for instructions)		Owner maintenance (see User’s Information Manual for instructions)	
ANNUAL START-UP	Inspect:	Daily	<ul style="list-style-type: none"> Check boiler area Check boiler pressure gauge Check air openings
	<ul style="list-style-type: none"> Reported problems Boiler area Air openings Flue gas vent system Pilot and main burner flames Piping Boiler heating surfaces Burners and base 	Monthly	<ul style="list-style-type: none"> Check boiler and system piping Check venting system Check/operate boiler relief valve Check pilot and main burner flames
	Service:	Periodically	<ul style="list-style-type: none"> Test low water cutoff (if used)
	Start-up:	End of season	<ul style="list-style-type: none"> Shut down procedure
Check/test:			
<ul style="list-style-type: none"> Gas piping Boiler waterline Limit controls and cutoffs Boiler relief valve 			
Review:			
<ul style="list-style-type: none"> Review with owner 			

⚠ WARNING Follow the “Service and maintenance” procedures given throughout this manual and in component literature shipped with the boiler. See “Read this first!” on page 2. Failure to perform the service and maintenance could result in damage to the boiler or system. Failure to follow the directions in this manual and component literature could result in severe personal injury, death or substantial property damage.

10 Service and maintenance continued

⚠ WARNING The boiler should be inspected and started annually, at the beginning of the heating season, only by a qualified service technician. In addition, the maintenance and care of the boiler designated in Table 9, page 29 and explained on the following pages must be performed to assure maximum boiler efficiency and reliability. Failure to service and maintain the boiler and system could result in equipment failure.

⚠ WARNING **Electrical shock hazard** — Turn off power to the boiler before any service operation on the boiler except as noted otherwise in this manual. Failure to turn off electrical power could result in electrical shock, causing severe personal injury or death.

⚠ WARNING The boiler contains ceramic fiber and fiberglass materials. Use care when handling these materials per instructions on page 22 of this manual. Failure to comply could result in severe personal injury.

□ Inspect

Reported problems

Inspect any problems reported by owner and correct before proceeding.

Boiler area

1. Verify that boiler area is free of any combustible materials, gasoline and other flammable vapors and liquids.
2. Verify that boiler area is free of any of the contaminants listed in Table 2, on page 5 of this manual. If any of these are present in the boiler intake air vicinity, they must be removed. If they cannot be removed, install combustion air piping to the boiler in accordance with national, provincial or local codes.

Air openings

1. Verify that combustion and ventilation air openings to the boiler room and/or building are open and unobstructed. Check operation and wiring of automatic combustion air dampers, if used.
2. Verify that boiler vent discharge and air intake are clean and free of obstructions.

Flue gas vent system

1. Visually inspect entire flue gas venting system for blockage, deterioration or leakage. Repair any joints that show signs of leakage in accordance with vent manufacturer's instructions.
2. Verify that masonry chimneys are lined, lining is in good condition, and there are not openings into the chimney.

⚠ WARNING Failure to inspect for the above conditions and have them repaired can result in severe personal injury or death.

Pilot and main burner flames

Visually inspect pilot burner and main burner flames as directed under Section 7, page 21 of this manual.

□ Inspect

Piping

1. Check the boiler interior piping and all system piping for signs of leaks.
2. Repair any leaks before proceeding.

⚠ DANGER Do not use petroleum-based cleaning or sealing compounds in boiler system. Severe damage to boiler will occur, resulting in substantial property damage.

⚠ WARNING Eliminate all system or boiler leaks. Continual fresh makeup water will reduce boiler life. Minerals can build up in sections, reducing heat transfer, overheating cast iron, and causing section failure. Leaking water may also cause severe property damage.

Boiler heating surfaces

⚠ WARNING The boiler contains ceramic fiber and fiberglass materials. Use care when handling these materials per instructions on page 22 of this manual. Failure to comply could result in severe personal injury.

1. Disconnect the vent pipe at the boiler draft hood and remove draft hood after turning off power to the boiler.
2. Use a bright light to inspect the boiler flue collector and heating surfaces.
3. If the vent pipe or boiler interior surfaces show evidence of soot, follow "Cleaning boiler heating surfaces", page 24. Remove the flue collector and clean the boiler if necessary after closer inspection of boiler heating surfaces.
4. If there is evidence of rusty scale deposits on boiler surfaces, check the water piping and control system to make sure the boiler return water temperature is properly maintained (per this manual).
5. Reconnect vent and draft hood. Replace all boiler components before returning to service.
6. Check inside and around boiler for evidence of any leaks from the boiler. If found, locate source of leaks and repair.

Burners and base

1. After turning off power to the boiler, remove the jacket door and base access panel (Figure 25, item 4, page 38).
2. Inspect burners and all other components in the boiler base.
3. If burners must be cleaned, raise rear of each burner to release from support slot, slide forward and remove. Then brush and vacuum the burners thoroughly, making sure all ports are free of debris. Carefully replace all burners, making sure burner with pilot bracket is replaced in its original position and all burners are upright (ports up).
4. Inspect the base insulation.
 - a. Verify that the insulation is intact and secure against all four sides of the base.

⚠ WARNING If insulation is damaged or displaced, do not operate the boiler. Replace or reposition insulation as necessary. Failure to replace damaged insulation can result in a fire hazard, causing severe personal injury, death or substantial property damage.

10 Service and maintenance continued

□ Service

Gauge glass

Normal waterline is halfway up gauge glass. Clean when needed.

1. Close lower gauge cock.
2. Open pet cock.
3. Open lower gauge cock and allow a small amount of water to flush out through open pet cock.
4. Close pet cock.
5. Open lower gauge cock.

⚠ DANGER Boiler pressure must be low to eliminate potential of severe burns.

⚠ WARNING If gauge glass breaks, close both gauge cocks. Replace gauge glass. Do not replace with thin glass tubing. Failure to comply could cause severe personal injury, death or substantial property damage.

□ Start-up

1. Perform Start-up procedures, Section 7, pages 19 - 21, including Verify operation of burners and vent damper on page 21.
2. Check gas piping, per pages 15 and 19, verifying no indications of leakage and all piping and connections are in good condition.
3. Read the Operating Instructions starting on page 23.
4. Start the boiler following the Operating Label Instructions starting on page 24.

□ Check/test

Gas piping

1. Sniff near floor and around boiler area for any indication of a gas leak.
2. Test gas piping using bubble test, per page 15 of this manual, if there is any indication of a leak.

Boiler waterline

Normal waterline is halfway up gauge glass.

Limit controls

1. Inspect and test the boiler limit control. Verify operation by turning control set point below boiler pressure. Boiler should cycle off. Return dial to original setting.

□ Check/test

Low water cutoffs

Probe-type low water cutoff (see below)

Clean probe-type low water cutoff for proper operation.

1. Turn off power to boiler and wait 5 minutes.
2. Drain water to bottom of gauge glass.
3. Turn on power.
4. Set thermostat to call for heat. Red neon lamp on lower water cutoff should light.
5. Wait 5 minutes. Boiler should not fire.
6. Refill boiler to correct waterline. Red lamp should go off.
7. Wait 5 minutes. Boiler should fire.
8. Return thermostat to normal setting.

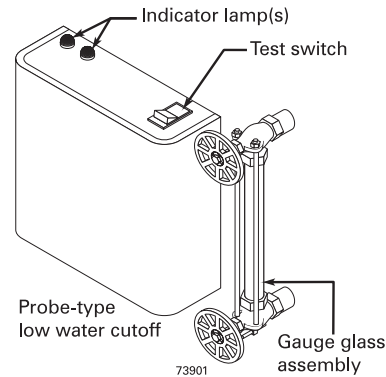

Float-type low water cutoff (when provided by others — see below)

Clean float-type low water cutoff (when provided by others) to clear float chamber of sediment.

1. Open blowdown valve at bottom control.
2. Drain water into a bucket.

⚠ DANGER Scald potential. Boiler pressure must be low to avoid the potential of severe burns from steam.

3. Check float-type low water cutoff for proper operation:
 - a. Turn operating control to call for heat.
 - b. Before water gets hot, drain to bottom of gauge glass. Boiler should shut off after water level lowers a few inches.
 - c. Refill boiler to correct waterline. Boiler should come back on.

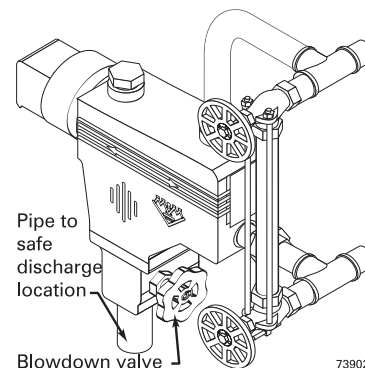

10 Service and maintenance continued

☐ Check/test

Boiler relief valve

1. After following the warning directions below, if the relief valve weeps or will not seat properly, replace the relief valve.

⚠ DANGER Before testing, make certain discharge pipe is properly connected to valve outlet and arranged to contain and safely dispose of boiler discharge. Wear gloves to protect your hands from hot surfaces. Verify that discharge piping is installed in accordance with this manual and the instructions on the relief valve tag. Failure to comply will expose operator and others to severe personal injury or death.

⚠ WARNING Safety relief valves should be reinspected AT LEAST ONCE EVERY THREE YEARS, by a licensed plumbing contractor or authorized inspection agency, to ensure that the product has not been affected by corrosive water conditions and to ensure that the valve and discharge line have not been altered or tampered with illegally. Certain naturally occurring conditions may corrode the valve or its components over time, rendering the valve inoperative. Such conditions are not detectable unless the valve and its components are physically removed and inspected. This inspection must only be conducted by a plumbing contractor or authorized inspection agency — not by the owner. Failure to reinspect the boiler relief valve as directed could result in unsafe pressure buildup, which can result in severe personal injury, death or substantial property damage.

⚠ WARNING Check the setting of the boiler limit control. The control should never be set with a pressure above 10 psig. Operating at a higher pressure can cause damage to the boiler relief valve.

⚠ WARNING The boiler relief valve must be tested at least monthly during the heating season to verify the valve and discharge piping flow freely. If corrosion and/or deposits are noticed within the valve body, testing must be performed more often. A “try lever test” must also be performed at the end of any non-service period. Follow the instructions below for a “try lever test”:

- With the system at operating pressure, lift and hold the test lever fully open for at least 5 seconds to flush the valve seat free of sediment and debris. Then release lever and permit the valve to snap shut.

☐ Review with owner

1. Review the User’s Information Manual with the owner.
2. Emphasize the need to perform the maintenance schedule specified in the User’s Information Manual (and in this manual as well).
3. Remind the owner of the need to call in a licensed contractor should the boiler or system exhibit any unusual behavior.
4. Remind the owner to follow the proper shutdown procedure and to schedule an annual start-up at the beginning of the next heating season.

☐ Cleaning boiler heating surfaces

⚠ WARNING The boiler contains ceramic fiber and fiberglass materials. Use care when handling these materials per instructions on page 22 of this manual. Failure to comply could result in severe personal injury.

1. Shut down boiler — Follow “To Turn Off Gas to Appliance” instructions on boiler and Operating Instructions starting on page 24.
2. Disconnect breeching and remove damper and draft hood.
3. Remove upper rear jacket panel. Turn back jacket insulation to expose collector hood.
4. Remove collector hood. Clean excess boiler cement from collector hood and cast iron sections.
5. Remove burners from base of boiler. Follow “Burners and base” on page 30, to thoroughly clean burners. Place newspaper in base of boiler to collect soot that will fall.
6. With a wire flue brush, clean between the sections.
7. Remove paper and soot. Vacuum or brush base and surrounding area.
8. Replace collector hood. Seal with boiler cement.

11 Troubleshooting

CAUTION Label all wires prior to disconnection when servicing controls. Wiring errors can cause improper and dangerous operation.

WARNING Never jumper (bypass) rollout thermal fuse element or any other device except for momentary testing, see page 8. Severe personal injury, death or substantial property damage can result.

WARNING Burner base access panel must be in position during boiler operation to prevent momentary flame rollout on ignition of main flame. Severe personal injury or substantial property damage will result.

Before troubleshooting:

1. Have the following items:
 - a. Voltmeter that can check 120VAC and 24VAC.
 - b. Continuity checker.
 - c. U-tube manometer.
2. Check for 120VAC (minimum 102VAC to maximum 132VAC) to boiler.
3. Make sure thermostat is calling for heat and contacts (including appropriate zone controls) are closed. Check for 24VAC between each thermostat wire nut and ground.

Troubleshooting sequence:

1. Before proceeding, check for:
 - Loose connections, blown fuse or service switch off?
 - High limit switch set below boiler water temperature?
 - Thermostat set below room temperature?
 - Gas not turned on at meter or boiler?
 - Incoming gas pressure less than:
 - 5" w.c. for natural gas? 11" w.c. for propane gas?
2. If all of the above check correctly, check gas pressures:
 - a. With boiler off:
 - 13" w.c. maximum natural or propane gas pressure upstream of gas valve.
 - b. With boiler on:
 - 5" w.c. minimum natural gas pressure or 11" w.c. propane gas pressure upstream of gas valve.
 - 3.5" w.c. minimum natural gas pressure or 10" w.c. propane gas pressure downstream tapping on gas valve — Can be adjusted by regulator on gas valve.
 - c. If gas pressure is incorrect or gas is not available to boiler, contact gas supplier to correct before proceeding further.

In event of vent damper failure:

Effikal or Field Controls vent dampers

If troubleshooting chart recommends replacing actuator and actuator is not immediately available, damper blade can be fixed in an open position to allow boiler operation. Manually turning blade can cause actuator damage. Follow these instructions only in case of no heat or damper actuator malfunction.

1. Move damper service switch to Hold Damper Open position. Apply call for heat to boiler. Damper blade should then rotate to Open position and boiler will fire.
2. If step 1 does not open damper, manually rotate damper blade to open position using wrench or pliers on flat shaft between damper and actuator. Boiler will fire. Verify that damper service switch is in Hold Damper Open position. See Figure 24.
3. Do not leave vent damper permanently in this position. Replace actuator immediately. If vent damper is left in Open position, boiler will not operate at published efficiencies.

Figure 24 Manually opening vent damper

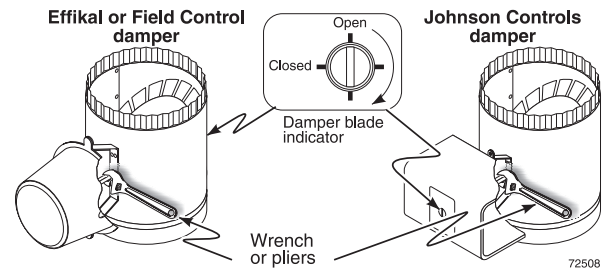

WARNING Verify proper operation after servicing. • See vent damper manufacturer's instructions packed with vent damper for additional information. Failure to comply could result in severe personal injury, death or substantial property damage.

11 Troubleshooting continued

CHART 1: NO SPARK – System does not work – Without vent damper

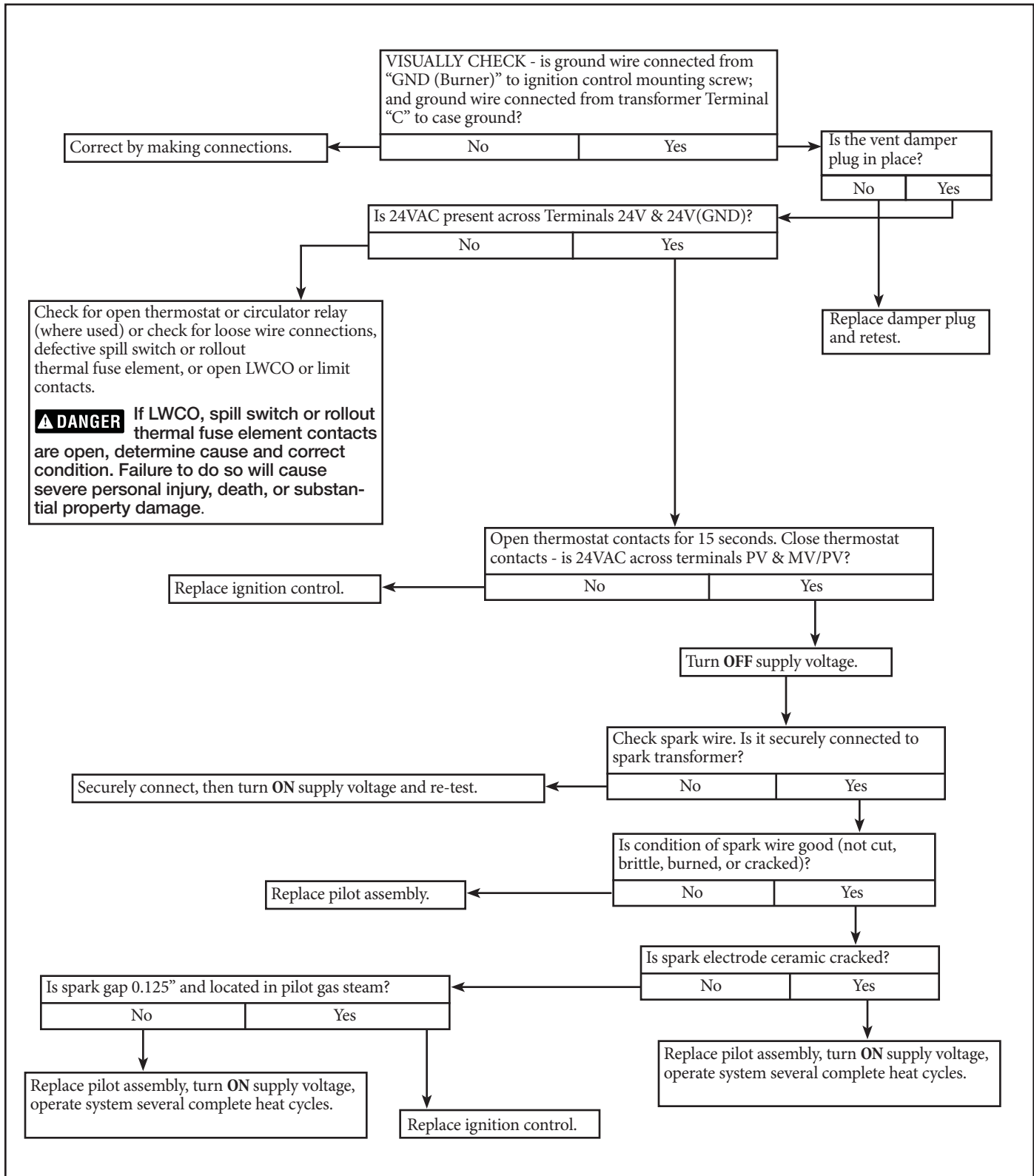

11 Troubleshooting continued

CHART 2: NO SPARK – System does not work – With vent damper

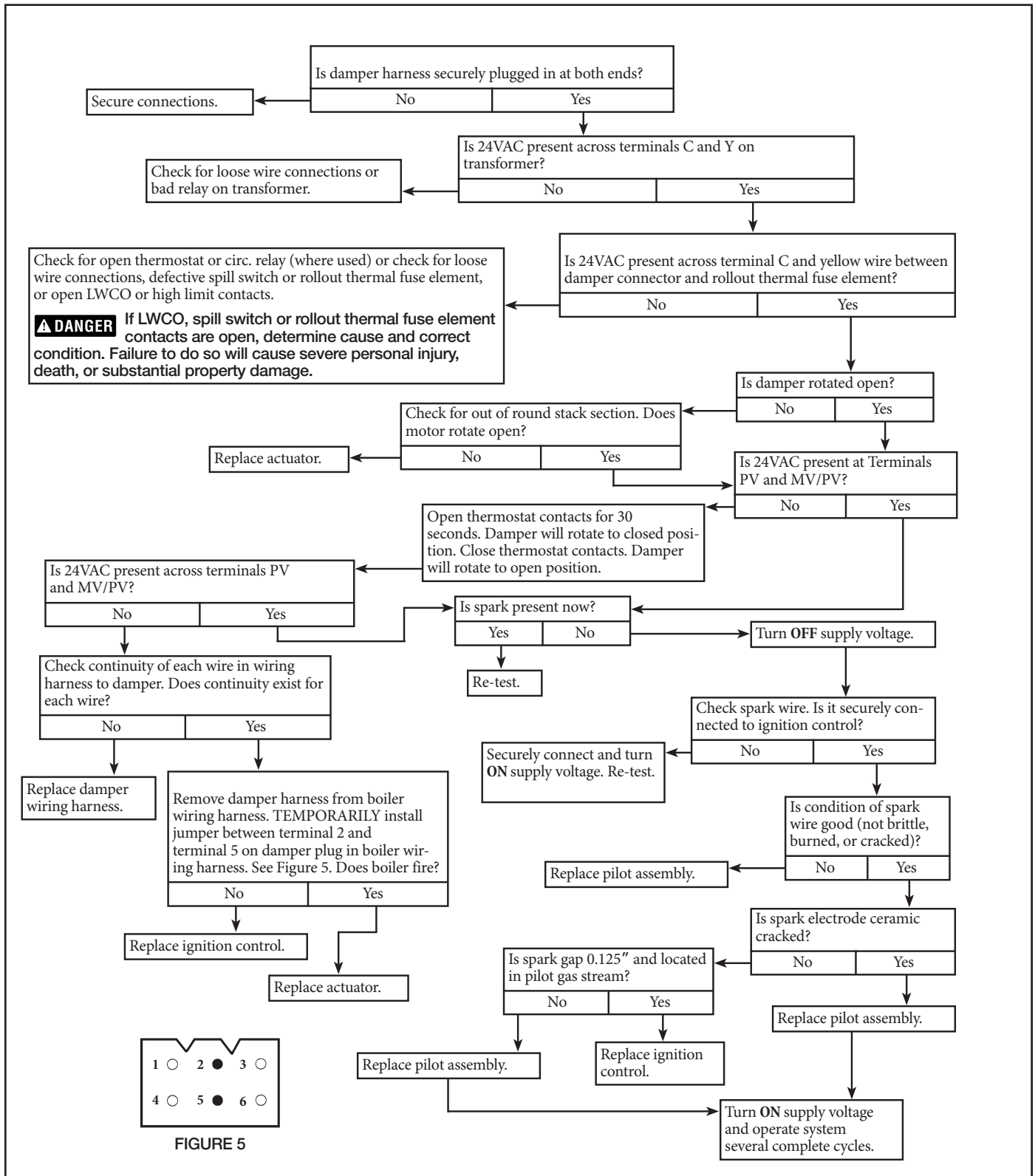

11 Troubleshooting continued

CHART 3: PILOT LIGHTS – Main valve will not come on – With or without vent damper

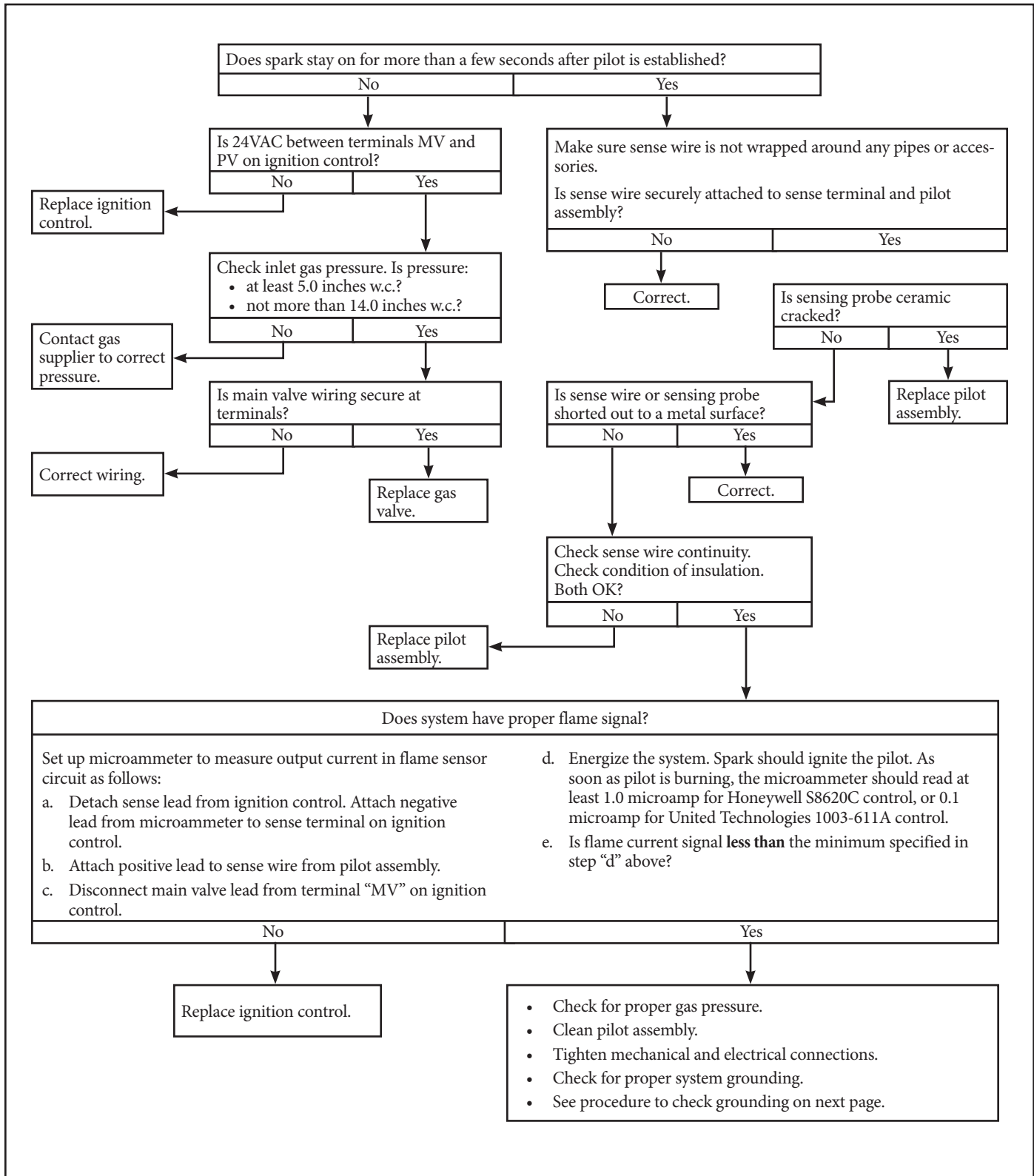

11 Troubleshooting continued

CHART 3 (continued): Procedure to check system grounding

Pilot assembly and ignition control must share common ground with main burner. Nuisance shutdowns are often caused by poor or erratic ground.

- Check for good metal-to-metal contact between pilot burner bracket and main burner, and between main burner and burner rest.

- Check ground lead from “GND (Burner)” terminal on ignition control to ignition control mounting screw, and from “C” on transformer to transformer case ground. Make sure connections are clean and tight. If wire is damaged or deteriorated, replace with No. 18 gauge moisture-resistant, thermoplastic-insulated wire with 105°C minimum rating.

CHART 4: PILOT LIGHTS – Main valve will not come on – With or without vent damper

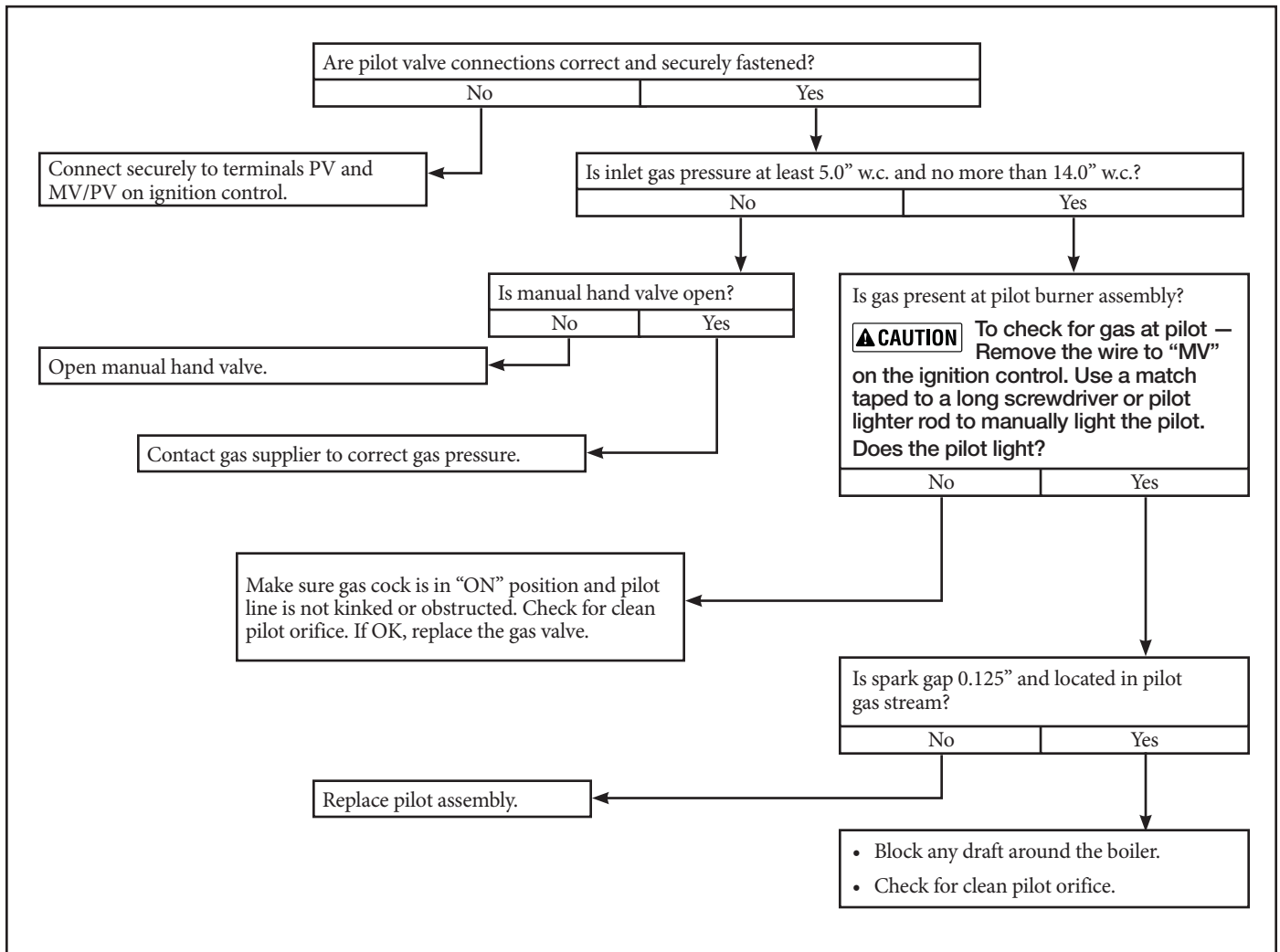

12 Replacement parts

Figure 25 Section assembly, flue collector, draft hood, vent damper and base assembly

WARNING The boiler contains ceramic fiber and fiberglass materials. Use care when handling these materials per instructions on page 22 of this manual. Failure to comply could result in severe personal injury.

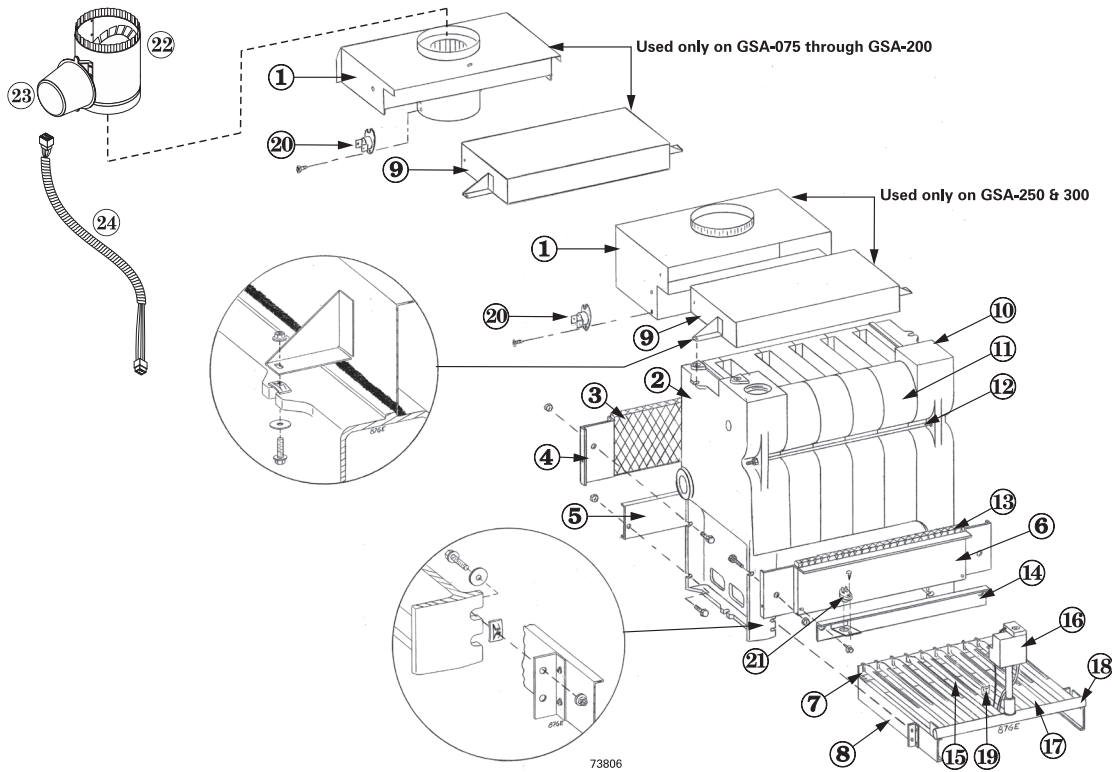

Item number	Description	Part number
1	Drafthood	GSA-075 450-021-255WT
		GSA-100 450-021-256WT
		GSA-125 450-021-257WT
		GSA-150 450-021-258WT
		GSA-175 450-021-259WT
		GSA-200 450-021-260WT
		GSA-250 450-021-261WT
GSA-300 450-021-262WT		
	Base insulation kit: Consists of items 3 and 13.	510-811-660WT
2	End section, left hand, 1813	311-800-007WT
3	Back base panel insulation (in base insulation kit)	
4	Back base panel	GSA-075 & GSA-100 451-800-010WT
		GSA-125 & GSA-150 451-800-011WT
		GSA-175 & GSA-200 451-800-012WT
		GSA-250 451-800-013WT
		GSA-300 451-800-014WT
5	Back base channel	GSA-075 & GSA-100 451-800-020WT
		GSA-125 & GSA-150 451-800-021WT
		GSA-175 & GSA-200 451-800-022WT
		GSA-250 & GSA-300 451-800-023WT
6	Front base panel	GSA-075 & GSA-100 451-800-000WT
		GSA-125 & GSA-150 451-800-001WT
		GSA-175 & GSA-200 451-800-002WT
		GSA-250 451-800-003WT
		GSA-300 451-800-004WT
7	Back burner support	GSA-075 451-800-085WT
		GSA-100 451-800-086WT
		GSA-125 451-800-087WT
		GSA-150 451-800-088WT
		GSA-175 451-800-089WT
		GSA-200 451-800-090WT
		GSA-250 451-800-092WT
GSA-300 451-800-095WT		
8	Burner pan side rail	451-800-070WT
9	Collector hood	GSA-075 & GSA-100 450-014-733WT
		GSA-125 & GSA-150 450-014-734WT
		GSA-175 & GSA-200 450-014-735WT
		GSA-250 450-014-736WT
		GSA-300 450-014-737WT
	Section replacement kit (Consists of: rope glass and 1 each 3" and 6" square cut seals)	381-800-100WT
10	End section, right hand, 18128	311-800-029WT
11	Intermediate section, 1815	311-800-010WT

Item number	Description	Part number
12	Tie rod, ½"	GSA-075 & GSA-100 560-234-470WT
		GSA-125 & GSA-150 560-234-475WT
		GSA-175 & GSA-200 560-234-480WT
		GSA-250 560-234-485WT
		GSA-300 560-234-490WT
13	Front base panel insulation (in base insulation kit)	
14	Base access panel	GSA-075 & GSA-100 451-800-040WT
		GSA-125 & GSA-150 451-800-041WT
		GSA-175 & GSA-200 451-800-039WT
		GSA-250 451-800-042WT
		GSA-300 451-800-044WT
15	Burner Regular Burner Assembly with pilot bracket (GSA-075N-I thru GSA-250N-I)	512-200-000WT
		512-200-001WT
16	Gas valve – see Controls on page 38	
17	Main burner orifice – Natural gas	560-528-987WT
18	Burner manifold	GSA-075 591-125-533WT
		GSA-100 591-125-538WT
		GSA-125 591-125-534WT
		GSA-150 591-125-539WT
		GSA-175 591-125-535WT
		GSA-200 591-125-540WT
		GSA-250 591-125-541WT
		GSA-300 591-125-542WT
19	Pilot burner assembly – see Controls on page 38	
20	Spill switch	510-300-013WT
21	Rollout thermal fuse element	512-050-230WT
22	Vent damper	5" (GSA-074 thru 100) 381-800-475WT
		6" (GSA-125 thru 150) 381-800-476WT
		7" (GSA-175 thru 200) 381-800-477WT
		8" (GSA-250 & 300) 381-800-478WT
23	Vent damper actuator	only with vent-damper above
24	Vent damper harness	591-391-795WT

12 Replacement parts continued

Figure 26 Jacket assembly

⚠ WARNING The boiler contains ceramic fiber and fiberglass materials. Use care when handling these materials per instructions on page 22 of this manual. Failure to comply could result in severe personal injury.

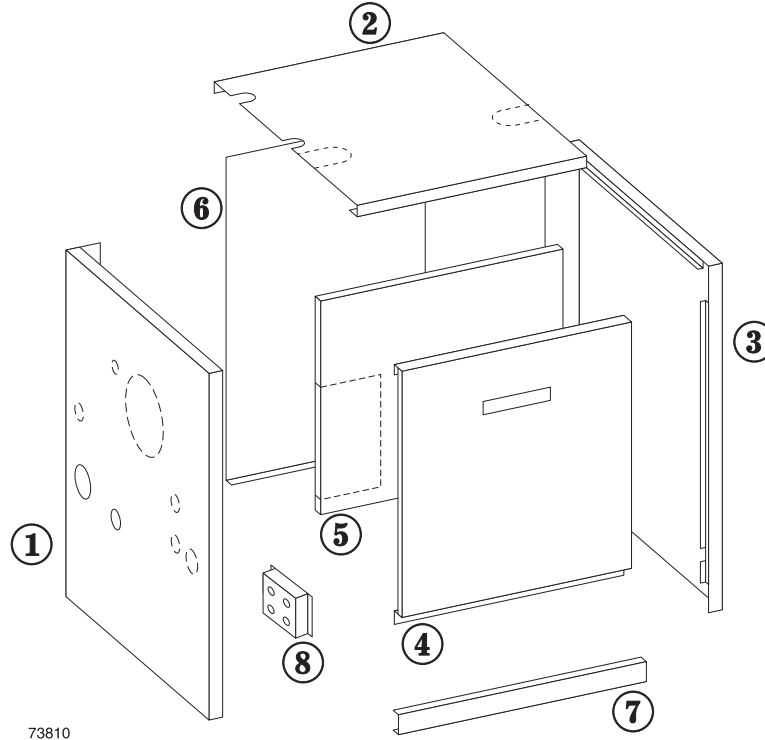

73810

Item number	Description	Part number
1	Jacket panel, left side	421-800-150WT
2	Jacket panel, top	GSA-075 & GSA-100 421-800-152WT GSA-125 & GSA-150 421-800-153WT GSA-175 & GSA-200 421-800-154WT GSA-250 421-800-155WT GSA-300 421-800-156WT
3	Jacket panel, right side	GSA-075 421-800-198WT GSA-100 421-800-199WT GSA-125 421-800-200WT GSA-150 421-800-201WT GSA-175 421-800-202WT GSA-200 421-800-210WT GSA-250 421-800-211WT GSA-300 421-800-212WT
4	Jacket panel, door	GSA-075 & GSA-100 421-800-167WT GSA-125 & GSA-150 421-800-168WT GSA-175 & GSA-200 421-800-169WT GSA-250 421-800-170WT GSA-300 421-800-171WT
5	Jacket panel, interior	GSA-075 & GSA-100 421-800-162WT GSA-125 & GSA-150 421-800-163WT GSA-175 & GSA-200 421-800-164WT GSA-250 421-800-165WT GSA-300 421-800-166WT
6	Jacket panel, rear	GSA-075 & GSA-100 421-800-157WT GSA-125 & GSA-150 421-800-158WT GSA-175 & GSA-200 421-800-159WT GSA-250 421-800-160WT GSA-300 421-800-161WT
7	Bottom cross tie	GSA-075 & GSA-100 421-800-172WT GSA-125 & GSA-150 421-800-173WT GSA-175 & GSA-200 421-800-174WT GSA-250 421-800-175WT GSA-300 421-800-190WT
8	Junction box, 4 x 4 (Available at local supply house)	

12 Replacement parts continued

Figure 27 Controls and trim

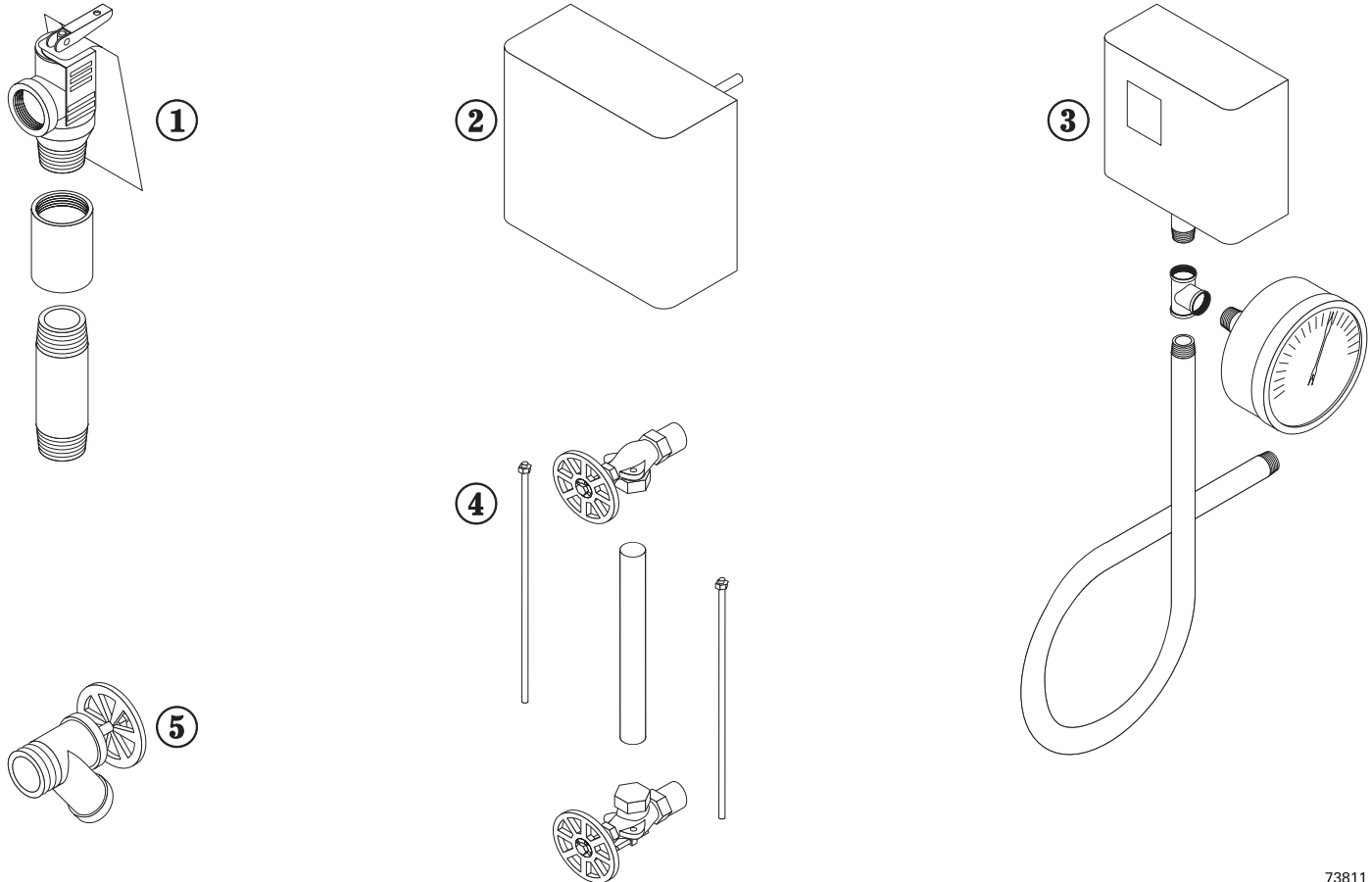

73811

Item number	Description	Manufacturer	Manufacturer's part number	Part number
1	Pressure relief valve, ASME, 15 PSIG, ¼" NPT <i>(Fittings shown are factory-installed on boiler. Coupling ¾" NPT, Nipple ¾" NPT)</i>	Conbraco Watts	13-501-08 315	511-548-023WT
2	Low water cutoff, probe-type	Hydrolevel	400	511-114-515WT
3	Limit control/gauge assembly, includes: Pressure control Gauge, steam Siphon, ¼" NPT, 90° brass Nipple, close ¼" NPT Tee, ¼" NPT	Honeywell Winter's	PA-404-A E1437	510-312-135WT 510-218-045WT obtain locally obtain locally obtain locally
4	Gauge glass assembly, includes: Gauge glass Gauge glass guard, 9⅝" Gauge cock set, brass	Conbraco United Brass Works	21-205-03-W 905 and 946	591-419-185WT 563-334-580WT 510-218-145WT
5	Drain valve, ¾"			511-210-423WT

12 Replacement parts continued

Figure 28 Spark Ignition Gas Controls

Description	Supplier part number	Part number
Damper Assembly 5.00" (GSA 075-100)	Effikal RVGP-KS-5BKF Field Controls GVD-5	381-800-475WT
6.00" (GSA 125-150)	Effikal RVGP-KS-6BKF Field Controls GVD-6	381-800-476WT
7.00" (GSA 175-200)	Effikal RVGP-KS-7BKF Field Controls GVD-7	381-800-477WT
8.00" (GSA 250 & 300)	Effikal RVGP-KS-8BKF Field Controls GVD-8	381-800-478WT
Damper Actuator	Effikal RVGP	510-512-337WT
Damper Harness	Weil-McLain	591-391-795WT
UCS Ignition Control	Honeywell S8620C1003 United Technologies 1003-611A	511-330-097WT
Wiring Harness (in Envelope Assy), GSA 075-250, Steam w/Probe LWCO		540-130-990WT
Pilot Burner Assembly	Precision Speed Equipment PSE-NA16	511-330-218WT
Gas Valve, 1/2" x 1/2", Sizes GSA 075-175 Natural Gas	Honeywell VR8204A2001 White-Rodgers 36E36-266 Robertshaw 7200IPER	511-044-381WT
Gas Valve, 3/4" x 3/4", Sizes GSA 200-300 Natural Gas 1.2 Step	Honeywell VR8304P4348 White-Rodgers 36C74-474	511-044-382WT

13 Dimensions

Figure 29 Dimensional drawing – ALL DIMENSIONS IN INCHES

- ① Supply piping (Note 1)
- ② Return piping (Note 1)
- ③ Gas supply piping
- ④ Gas supply entrance (right or left side)
- ⑤ Drain valve
- ⑥ Skim tapping
- ⑦ Manual main shutoff valve

⚠ DANGER

Do not cut or alter draft hood in any way. Boiler combustion will be affected, causing severe personal injury, death or substantial property damage.

Note 1: Boiler supply and return tappings can be found in the table below. See Piping section for recommended system supply and return piping sizes.

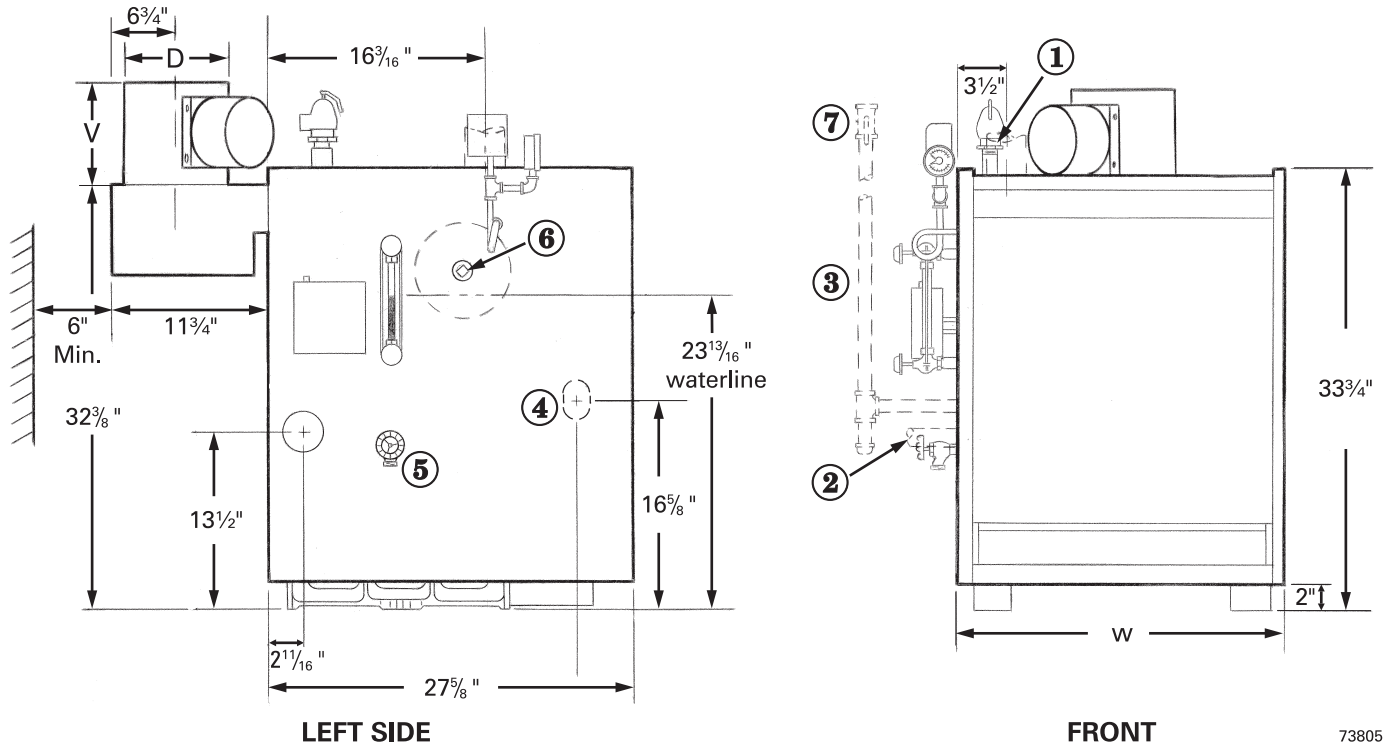

73805

Boiler Model Number	Supply tapping (inches NPT)	Return tapping (inches NPT)	Gas connection & manifold size (Note 2) (inches NPT)	"V" Damper height (inches)	"D" Vent diameter (inches)	"W" Jacket width (inches)	Approximate shipping weight
GSA-075	3	2 1/2	1/2	6	5	17	430
GSA-100	3	2 1/2	1/2	6	5	17	430
GSA-125	3	2 1/2	1/2	6 1/2	6	21 1/4	505
GSA-150	3	2 1/2	1/2	6 1/2	6	21 1/4	505
GSA-175	3	2 1/2	1/2	9	7	25 1/2	585
GSA-200	3	2 1/2	1/2	9	7	25 1/2	585
GSA-250	3	2 1/2	3/4	9 1/2	8	29 3/4	660
GSA-300	3	2 1/2	3/4	Note 3	Note 3	34	735

Note 2: Size gas piping from meter to boiler per local utility requirements.

Note 3: GSA-300 the damper is additional equipment.

14 Ratings

Figure 30 GSA Ratings

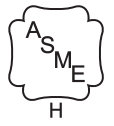

Boiler Model Number	AHRI Certified Ratings					Input	Output	Boiler Water content	Chimney and breaching
	Input	Heating Capacity	Seasonal Efficiency	Steam	Steam				
	0-2,000 feet altitude								
(Note 3)	(Btuh)	(Btuh) (Note 1)	AFUE % (Note 3)	(Btuh) (Note 2)	Sq. Ft.	(Btuh) (Note 4)		(Gallons) (to waterline)	(Size)
GSA-075	75,000	62,000	83.0	47,000	196	67,500	56,000	8.4	5" I.D. x 20'
GSA-100	100,000	83,000	82.9	62,000	258	90,000	74,700	8.4	5" I.D. x 20'
GSA-125	125,000	103,900	82.9	78,000	325	112,000	93,000	9.8	6" I.D. x 20'
GSA-150	150,000	124,700	82.9	94,000	392	135,000	112,200	9.8	6" I.D. x 20'
GSA-175	175,000	145,400	82.8	109,000	454	157,500	130,900	11.2	7" I.D. x 20'
GSA-200	200,000	166,600	82.8	125,000	521	180,000	149,900	11.2	7" I.D. x 20'
GSA-250	250,000	208,800	83.0	157,000	654	225,000	187,900	12.6	8" I.D. x 20'
GSA-300	299,000	249,000	82.4	185,000	770	270,000	216,000	14.0	8" I.D. x 20'

Notes

1. Based on standard test procedures prescribed by the United States Department of Energy.
2. Net AHRI ratings are based on net installed radiation of sufficient quantity for the requirements of the building and nothing need be added for normal piping and pickup. Ratings are based on a piping and pickup allowance of 1.333. An additional allowance should be made for unusual piping and pickup loads.
3. See information at right for model number suffixes. Letters shown are model number suffixes. An "N" after the model number designates natural gas.
4. Contact your local dealer regarding information and parts for high altitude applications.

