

GWA

Series 2 Gas-Fired Water Boilers

Boiler Manual



Contents	Page
1 Prepare boiler location	2
2 Prepare boiler.....	6
3 Install water piping.....	10
4 Install gas piping.....	13
5 Field wiring	14
6 Start-up	15
7 Checkout procedure	18
8 Department of Energy Compliance	19
9 Sequence of operation	19
10 Operating Instructions	23
11 Service and maintenance.....	25
12 Troubleshooting	29
13 Replacement parts	40
14 Dimensions.....	45
15 Ratings	46
16 Notes.....	47

Hazard definitions

▲ DANGER Hazards that **will cause severe** personal injury, death or substantial property damage.

▲ WARNING Hazards that **can cause severe** personal injury, death or substantial property damage.

▲ CAUTION Hazards that **will or can cause minor** personal injury or property damage.

NOTICE Special instructions on installation, operation or maintenance that are important but not related to personal injury or property damage.

▲ WARNING **INSTALLER** — Read all instructions before installing. **Read page 2 first.** Follow all instructions in proper order to prevent personal injury or death.

- Consider piping and installation when determining boiler location.
- Any claims for damage or shortage in shipment must be filed immediately against the transportation company by the consignee.

▲ WARNING **USER** — Please read the following. Failure to comply could result in severe personal injury, death or substantial property damage.

- **This manual is for use only by your qualified heating installer/service technician.**
- Please see the User's Information Manual for your reference.
- Have the boiler serviced by a qualified service technician, at least annually.

▲ WARNING This manual must only be used by a **qualified heating installer/service technician.** Failure to comply could result in severe personal injury, death or substantial property damage.

NOTICE When calling or writing about the boiler — Please have:

- boiler model number from the boiler rating label and
- CP number from the boiler jacket. You may list the CP number in the space provided on the "Installation and service certificate" found on page 18.

Read this first!

▲WARNING Failure to adhere to the guidelines below can result in severe personal injury, death or substantial property damage.

▲WARNING The boiler contains ceramic fiber and fiberglass materials. Use care when handling these materials per instructions on **page 39** of this manual. Failure to comply could result in severe personal injury.

When servicing boiler —

1. To avoid electric shock, disconnect electrical supply before performing maintenance.
2. To avoid severe burns, allow boiler to cool before performing maintenance.

Boiler operation —

3. Do not block flow of combustion or ventilation air to boiler.
4. Should overheating occur or gas supply fail to shut off, do not turn off or disconnect electrical supply to circulator. Instead, shut off the gas supply at a location external to the appliance.
5. Do not use this boiler if any part has been under water. Immediately call a qualified service technician to inspect the boiler and to replace any part of the control system and any gas control that has been under water.

Boiler water —

6. DO NOT use petroleum-based cleaning or sealing compounds in boiler system. Water seal deterioration will occur, causing leakage between boiler sections, circulator flanges, diaphragm tanks or other system components. This can result in substantial property damage.
7. DO NOT use “homemade cures” or “boiler patent medicines”. Serious damage to boiler, personnel and/or property may result.
8. Continual fresh makeup water will reduce boiler life. Mineral buildup in sections reduces heat transfer, overheats cast iron, and causes section failure. Addition of oxygen and other gases can cause internal corrosion. Leaks in boiler or piping must be repaired at once to prevent makeup water.
9. Do not add cold water to hot boiler. Thermal shock can cause sections to crack.

Glycol — potential fire hazard —

All glycol is flammable when exposed to high temperatures. If glycol is allowed to accumulate in or around the boiler or any other potential ignition source, a fire can develop. In order to prevent potential severe personal injury, death or substantial property damage from fire and/or structural damage:

- Never store glycol of any kind near the boiler or any potential ignition source.
- Monitor and inspect the system and boiler regularly for leakage. Repair any leaks immediately to prevent possible accumulation of glycol.
- Never use automotive antifreeze or ethylene glycol in the system. Using these glycols can lead to hazardous leakage of glycol in the boiler system.

1 Prepare boiler location

Codes & checklist

Installations must follow these codes:

- Local, state, provincial, and national codes, laws, regulations and ordinances.
- National Fuel Gas Code, ANSI Z223.1–latest edition.
- Standard for Controls and Safety Devices for Automatically Fired Boilers, ANSI/ASME CSD-1, when required.
- National Electrical Code.
- For Canada only: B149.1 or B149.2 Installation Code, CSA C22.1 Canadian Electrical Code Part 1 and any local codes.

Certification

NOTICE The GWA boiler gas manifold and controls met safe operating and other performance criteria when boiler underwent tests specified in ANSI Z21.13–latest edition.

Before locating the boiler:

- Check for nearby connection to:
 - System water piping
 - Venting connections
 - Gas supply piping
 - Electrical power
- Check area around boiler. Remove any combustible materials, gasoline and other flammable liquids.

▲WARNING Failure to keep boiler area clear and free of combustible materials, gasoline and other flammable liquids and vapors can result in severe personal injury, death or substantial property damage.

- Boiler must be installed so that gas control system components are protected from dripping or spraying water or rain during operation or service.
- If new boiler will replace existing boiler, check for and correct system problems, such as:
 1. System leaks causing oxygen corrosion or section cracks from hard water deposits.
 2. Incorrectly-sized expansion tank.
 3. Lack of antifreeze in boiler water causing system and boiler to freeze and leak.

1 Prepare boiler location continued

Clearances

Service clearances

1. Provide minimum clearances for cleaning and servicing the boiler and for access to controls and components as listed in the table below:
2. Provide at least screwdriver clearance to jacket front panel screws for removal of front panel for inspection and minor service. If unable to provide at least screwdriver clearance, install unions and shutoff valves in system so boiler can be moved for servicing.

Service clearances:	Minimum
Top (for cleaning flueways)	35"
Front (for access to controls and components)	18"
Back	7"
Left side (for cleaning and servicing)	24"
Right side	7"

Minimum clearance to combustible materials

1. Hot water pipes must be at least ½" from combustible material.
2. Single-wall vent pipe must be at least 6 inches from combustible material.
3. Type B double-wall metal vent pipe — See vent manufacturer's recommendation for clearances to combustible material.

Clearances from combustible materials:	Minimum
Front (provide means of access)	3"
Back	7"
Left side (provide means of access)	6"
Right side	2"
Top	H
	GWA-052 to GWA-105
	35"
	GWA-140
	35½"
	GWA-175
	38½"
	GWA-210
	39¾"
	GWA-245
	42½"

Table 1 Minimum foundation size

Boiler model	Minimum foundation length	Minimum foundation width
GWA-052	25"	12"
GWA-070	25"	12"
GWA-105	25"	15"
GWA-140	25"	18"
GWA-175	25"	21"
GWA-210	25"	24"
GWA-245	25"	27"

Small space installations

1. When the boiler is located in a closet or small space, provide clearances no less than those shown in **Figure 1**. The clearances are required to any surface, whether combustible or non-combustible.

Figure 1 Minimum clearances

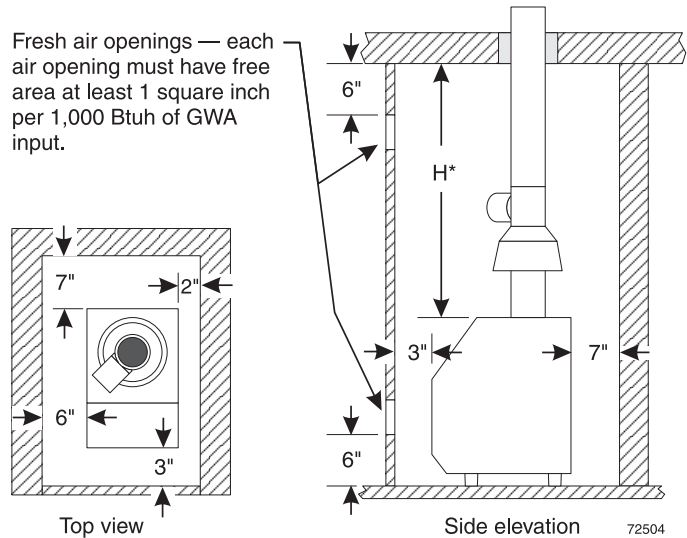

*See "Clearances from combustible materials" table.

Residential garage installation

Take the following special precautions when installing the boiler in a residential garage. If the boiler is located in a residential garage, per ANSI Z223.1, paragraph 5.1.9:

- Mount the boiler a minimum of 18 inches above the floor of the garage to assure the burner and ignition devices will be no less than 18 inches above the floor.
- Locate or protect the boiler so it cannot be damaged by a moving vehicle.

Flooring and foundation

Flooring

The GWA boiler is approved for installation on combustible flooring, but must never be installed on carpeting.

WARNING Do not install boiler on carpeting even if foundation is used. Fire can result, causing severe personal injury, death or substantial property damage.

Foundation

1. Provide a solid brick or minimum 2-inch thick concrete foundation pad if any of the following is true:
 - floor can become flooded.
 - the boiler mounting area is not level.
2. See **Table 1** for minimum foundation dimensions.

1 Prepare boiler location continued

Vent system

⚠ WARNING Failure to follow all instructions can result in flue gas spillage and carbon monoxide emissions, causing severe personal injury or death.

⚠ DANGER Inspect existing chimney before installing boiler. Failure to clean or replace perforated pipe or tile lining will cause severe personal injury or death.

⚠ DANGER Do not alter boiler draft hood or place any obstruction or non-certified vent damper in breeching or vent system. CSA certification will become void. Flue gas spillage and carbon monoxide emissions will occur causing severe personal injury or death.

NOTICE The following requirements apply when you remove an existing boiler from a vent system shared with other appliances. **If the new boiler will not use the common vent**, you must test (as described below) each remaining appliance — operating by itself — to verify that the vent system operates adequately.

When removing boiler from existing common vent system:

At the time of removal of an existing boiler, the following steps shall be followed with each appliance remaining connected to the common venting system placed in operation, while the other appliances remaining connected to the common venting system are not in operation.

- a. Seal any unused openings in the common venting system.
- b. Visually inspect the venting system for proper size and horizontal pitch and determine there is no blockage or restriction, leakage, corrosion or other deficiencies which could cause an unsafe condition.
- c. Test vent system — Insofar as is practical, close all building doors and windows and all doors between the space in which the appliances remaining connected to the common venting system are located and other spaces of the building. Turn on clothes dryers and any appliance not connected to the common venting system. Turn on any exhaust fans, such as range hoods and bathroom exhausts, so they will operate at maximum speed. Do not operate a summer exhaust fan. Close fireplace dampers.
- d. Place in operation the appliance being inspected. Follow the operating instructions. Adjust thermostat so appliance will operate continuously.
- e. Test for spillage at draft hood relief opening after 5 minutes of main burner operation. Use the flame of a match or candle.
- f. After it has been determined that each appliance remaining connected to the common venting system properly vents when tested as outlined above, return doors, windows, exhaust fans, fireplace dampers, and any other gas-burning appliance to their previous conditions of use.

Any improper operation of common venting system should be corrected so the installation conforms with the National Fuel Gas Code, ANSI Z223.1—latest edition. Correct by resizing to approach the minimum size as determined using the appropriate tables in Part 11 of that code. Canadian installations must comply with B149.1 or B149.2 Installation Code.

Chimney or vent requirements

1. Venting must be installed according to Part 7, “Venting of

Equipment”, of National Fuel Gas Code, ANSI Z223.1—latest edition and applicable building codes. Canadian installations must comply with B149.1 or B149.2 Installation Codes.

2. See “Ratings” on **Page 46** for minimum chimney or vent sizes. Chimney or vent termination:
 - A chimney, or any vent other than a Type B vent with listed vent cap, must extend at least 3 feet above the highest point where it passes through a roof of a building, and at least 2 feet higher than any portion of a building within a horizontal distance of 10 feet.
 - Type B vents with listed caps may terminate as in Figure 2 if no closer than 8 feet from a vertical wall or similar obstruction.
 - Otherwise, Type B vents must terminate at least 2 feet above the roof penetration and at least 2 feet higher than any portion of a building within 10 feet.
3. A lined chimney is preferred and must be used when required by local, state, provincial and national codes, laws, regulations and ordinances. Vitreous tile linings with joints that prevent retention of moisture and linings made of noncorrosive materials are best. Advice for flue connections and chimney linings can be obtained from local gas utility. Type B double-wall metal vent pipe or single-wall vent pipe may be used as a liner.
4. Cold masonry chimneys, also known as outside chimneys, typically have one or more walls exposed to outside air. When any atmospheric gas-fired boiler with automatic vent damper is vented through this type of chimney, the potential exists for condensation to occur. Condensation can damage a masonry chimney. The following are recommended to prevent possible damage.
 - a. Line chimney with corrosion-resistant metal liner such as AL29-4C® single-wall stainless steel or B-vent. Size liner per National Fuel Gas Code ANSI Z223.1—latest edition.
 - b. Provide drain trap to remove any condensate.
5. Where two or more gas appliances vent into a common chimney or vent, equivalent area should be at least equal to area of vent outlet on largest appliance plus 50 percent of vent outlet area of additional appliance.

Figure 2 Terminations with Type B vent fitted with listed cap, **provided vent is at least 8 feet from any vertical wall or similar obstruction**

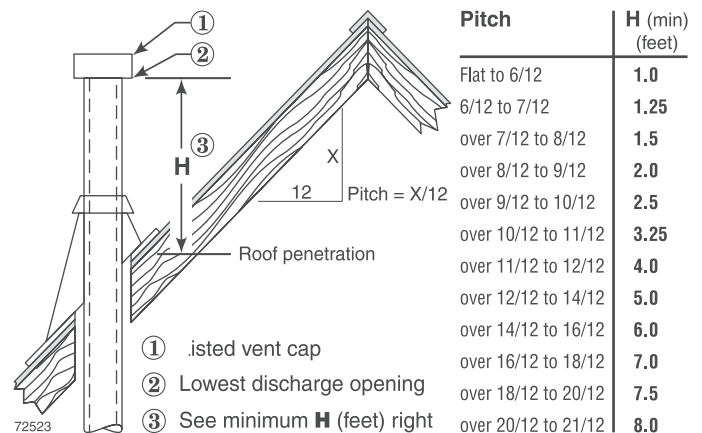

1 Prepare boiler location continued

Air contamination

Please review the following information on potential combustion air contamination problems.

See **Table 2** for products and areas which may cause contaminated combustion air.

⚠WARNING To prevent potential of severe personal injury or death, check for products or areas listed below before installing boiler. If any of these contaminants are found:

- Remove contaminants permanently.
— OR —
- Isolate boiler and provide outside combustion air. See national, provincial or local codes for further information.

Table 2 Corrosive contaminants and likely locations

Products to avoid
Spray cans containing chloro/fluorocarbons
Permanent wave solutions
Chlorinated waxes/cleaners
Chlorine-based swimming pool chemicals
Calcium chloride used for thawing
Sodium chloride used for water softening
Refrigerant leaks
Paint or varnish removers
Hydrochloric acid/muriatic acid
Cements and glues
Antistatic fabric softeners used in clothes dryers
Chlorine-type bleaches, detergents, and cleaning solvents found in household laundry rooms
Adhesives used to fasten building products and other similar products
Areas likely to have contaminants
Dry cleaning/laundry areas and establishments
Swimming pools
Metal fabrication plants
Beauty shops
Refrigeration repair shops
Photo processing plants
Auto body shops
Plastic manufacturing plants
Furniture refinishing areas and establishments
New building construction
Remodeling areas
Garages with workshops

Air openings

Combustion air and ventilation openings must comply with Section 5.3, “Air for Combustion and Ventilation”, of National Fuel Gas Code ANSI Z223.1—latest edition, or applicable local building codes. Canadian installations must comply with B149.1 or B149.2 Installation Codes.

See table below for minimum combustion/ventilation air opening sizes. Where openings are required, provide two (2) openings — one within 12 inches of the ceiling, the other within 12 inches of the floor, as shown in the table illustrations.

⚠WARNING Provide adequate combustion and ventilation air to assure proper combustion and reduce the risk of severe personal injury, death or substantial property damage caused by flue gas spillage and carbon monoxide emissions.

Minimum air opening sizes (See EXCEPTION below)

Required area of the air openings given in this table are **free area** — after the correction for louver obstruction.

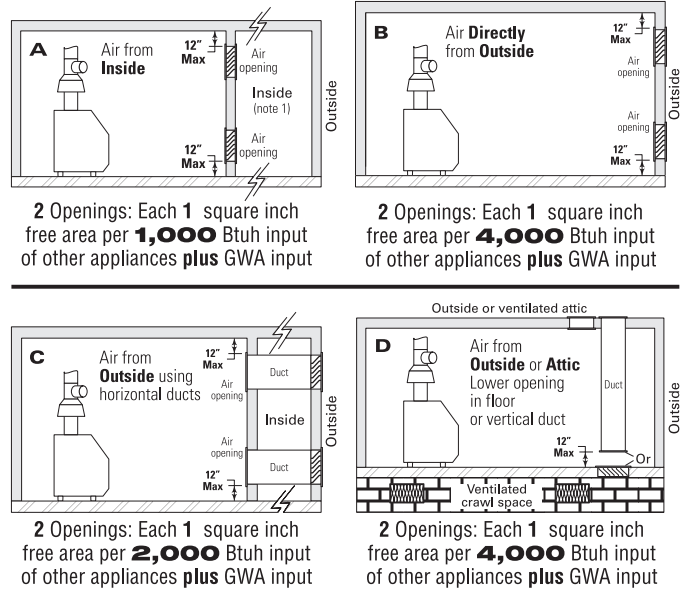

EXCEPTION: NO combustion air openings are needed when the boiler (and other appliances) are installed in a space with a volume **NO LESS** than 50 cubic feet per 1,000 Btuh of all installed appliances. Sum the total input of all appliances in MBH (1,000’s of Btuh) and multiply this number times 50. **Building must not be of Tight construction** (see below).

Example: For total input of 100 MBH (100,000 Btuh), minimum volume is 50 x 100 = 5,000 cubic feet. At a ceiling height of 8 feet, space must have at least 5,000 ÷ 8 = 625 square feet (25 feet x 25 feet, for instance).

Tight construction means (per ANSI Z223.1): • Walls and ceilings exposed to the outside atmosphere have a continuous water vapor retarder with a rating of 1 perm or less with openings gasketed. **AND** • Weather-stripping has been added on openable windows and doors. **AND** • Caulking or sealants are applied to areas such as joints around windows and door frames, between sole plates and floors, between wall-ceiling joints, between wall panels, at penetrations for plumbing, electrical, and gas lines, and in other openings.

Note 1: If building is of tight construction and air is taken from inside, as in A, provide two openings in building outside wall, one within 12 inches of ceiling, the other within 12 inches of the floor. Each opening must have a minimum free area of 1 square inch per 1,000 Btuh of all appliances in the building.

72540

1 Prepare boiler location continued

Air openings continued

Exhaust fans and air movers

The appliance space must never be under a negative pressure. Always provide air openings sized not only to the dimensions required for the firing rate of all appliances, but also to handle the air movement rate of the exhaust fans or air movers using air from the building or space.

Motorized air dampers

If the air openings are fitted with motorized dampers, electrically interlock the damper to:

- Prevent the boiler from firing if the damper is not fully open.
- Shut the boiler down should the damper close during boiler operation.

To accomplish this interlock, wire an *isolated contact* (proving the damper open) in series with the thermostat input to the boiler. The boiler will not start if this contact is open, and will shut down should it open during operation.

2 Prepare boiler

Placement and setup

Place boiler/crate near position

1. Leave boiler in crate and on pallet until installation site is ready.
 2. Move entire crate and pallet next to selected location.
 3. Remove crate. **Leave boiler on pallet.**
 4. Remove boiler from pallet as follows:
 - a. Tilt left side of boiler up and place a board under left legs.
 - b. Tilt boiler the other way and place a board under right legs.
 - c. Slide boiler backwards off pallet and into position.
- NOTICE** Do not drop boiler or bump jacket on floor or pallet. Damage to boiler can result.
5. Check level.
 - a. Shim legs, if necessary.
 - b. Do not alter legs.

WARNING The boiler contains ceramic fiber and fiberglass materials. Use care when handling these materials per instructions on **page 39** of this manual. Failure to comply could result in severe personal injury.

Inspect orifices and burners

1. Remove front jacket door. Remove base access panel (See Figure 19, item 4, page 40).
2. Check for correctly-sized manifold orifices. See Table 3 for sizing. (The orifice size is stamped on the orifice spud barrel.)

DANGER Correctly-sized manifold orifices must be used. Failure to do so will result in severe personal injury, death or substantial property damage.

3. Level and straighten burners.

DANGER Burners must be properly seated in slots in burner rest with their openings face up. Main burner orifices must inject down center of burner. Failure to properly seat burners will result in severe personal injury, death or substantial property damage.

4. Reinstall access panel.

CAUTION Do not operate boiler without access panel secured in place. Failure to comply could cause momentary flame rollout on ignition of main flame, resulting in possible fire or personal injury hazard.

Table 3 Manifold orifice sizing

Location	Natural gas		Propane gas	
	Sea level – 2,000 ft	over 2,000 ft	Sea level – 2,000 ft	over 2,000 ft
U. S.	2.00 mm	(Note 1)	1.30 mm	(Note 1)
Canada	2.00 mm	#49	1.30 mm	#56

Note 1: For U. S. elevations above 2,000 feet, contact your local supplier for details.

2 Prepare boiler continued

Pressure test

Perform hydrostatic pressure test

Pressure test boiler before attaching water or gas piping or electrical supply (except as noted below).

Prepare boiler for test

1. Remove the shipping nipple (from GWA supply tapping) and remove the boiler relief valve. Temporarily plug the relief valve tapping with a $\frac{3}{4}$ " NPT pipe plug.
2. Remove $\frac{1}{4}$ " nipple, reducing tee and drain valve from accessory bag. Install in boiler return connection as shown on in Figure 21, item 3, **page 42**. Install circulator on either the return or supply.
3. Remove $\frac{1}{4}$ " nipple, $\frac{1}{4}$ " tee, bushing and pressure/temperature gauge from accessory bag. Pipe to boiler supply connection as shown in Figure 21, item 2, **page 42**. (Use pipe dope sparingly.)
4. Connect a hose to boiler drain valve, the other end connected to a fresh water supply. Make sure hose can also be used to drain boiler after test.
5. Connect a nipple and shutoff valve to system supply connection on the $\frac{1}{4}$ " tee. This valve will be used to bleed air during the fill. (Valve and nipple are not included with boiler.)
6. Connect a nipple and shutoff valve to system return connection (at circulator flange if circulator installed on return). This valve will be used to bleed air during the fill. (Valve and nipple are not included with boiler.)
7. Temporarily plug the air elimination tapping (next to supply tapping).

Fill and pressure test

1. Open the shutoff valves you installed on supply and return connections.
2. Slowly open boiler drain valve and fresh water supply to fill boiler with water.
3. When water flows from shutoff valves, close boiler drain valve.
4. Close shutoff valves.
5. Slowly reopen boiler drain valve until test pressure of not more than 45 psi is reached on the pressure/temperature gauge.
6. Test at no more than 45 psi for no more than 10 minutes.



WARNING Do not leave boiler unattended. A cold water fill could expand and cause excessive pressure, resulting in severe personal injury, death or substantial property damage.

7. Make sure constant gauge pressure has been maintained throughout test. Check for leaks. Repair if found.



WARNING Leaks must be repaired at once. Failure to do so can damage boiler, resulting in substantial property damage.



DANGER Do not use petroleum-based cleaning or sealing compounds in boiler system. Severe damage to boiler will occur, resulting in substantial property damage.

Drain and remove fittings

1. Disconnect fill water hose from water source.
2. Drain boiler at drain valve or out hose, whichever provides best access to drain. Remove hose after draining if used to drain boiler.
3. Remove nipples, valves and plug unless they will remain for use in the system piping.
4. Remove plug from relief valve tapping. See **Section 3, page 10**, to replace relief valve.

2 Prepare boiler continued

Draft hood & spill switch

Draft hood installation

1. Orient draft hood with spill switch mounting holes to front of boiler as shown in **Figure 3**.
2. Secure draft hood to outlet at top of boiler with sheet metal screws.
3. Bottom of draft hood or *skirt* must have clearance dimension above jacket top panel as indicated on draft hood.

⚠ DANGER Do not alter boiler draft hood or place any obstruction or non-approved vent damper in breeching or vent system. CSA certification will become void. Flue gas spillage and carbon monoxide emissions will occur causing severe personal injury or death.

⚠ WARNING Improper orientation of spill switch may cause boiler to shut down. The loss of heat can result in significant damage due to freezing.

Spill switch installation

1. Fasten spill switch to draft hood as shown in **Figure 3**.
2. See Wiring diagram to connect wires:
Spark-ignited pilot boiler — see **pages 21 & 22**.

Figure 3 Spill switch with wire harness

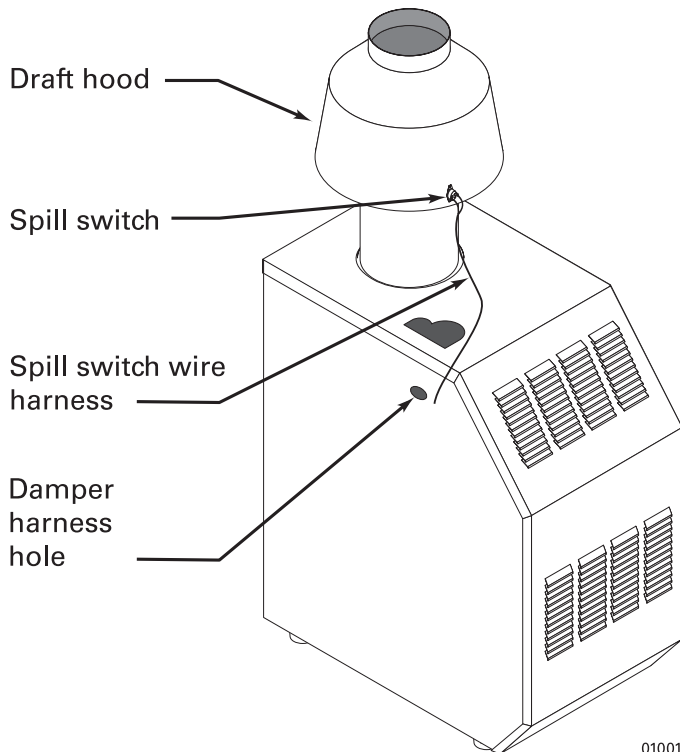

Install vent piping

1. Connect from draft hood or vent damper outlet to chimney or vent with same size vent connector.
2. Where possible, vertical venting to the outside from the draft hood or vent damper outlet will offer best performance.
3. Where horizontal vent connector is used, slope upward at least ¼" per lineal foot toward chimney or vent and support with hangers to prevent sagging.
4. Breeching must not be connected to any portion of a mechanical draft system that can operate under positive pressure.

⚠ WARNING Long horizontal vent connector, excessive number of elbow or tees, or other obstructions that restrict the flow of combustion gases should be avoided. Severe personal injury, death or substantial property damage could result.

Vent damper

NOTICE These systems are used on gas-fired boilers with vent dampers as shipped from factory. Boiler will not operate without vent damper installed.

⚠ WARNING Only vent dampers listed in the Replacement parts list on **Page 40** are certified for use with GWA boilers. Any other vent damper installed could cause severe personal injury or death.

Damper blade

Spark-ignited pilot systems— See vent manufacturer's instructions to install plug (shipped with damper) in damper hole. For spark-ignited pilot boilers only, install plug with no hole in vent damper hole.

Minimum clearances

Provide a minimum of 6" between the vent damper and any combustible material. (See "Minimum clearance to combustible materials," **page 3**, for minimum clearance from jacket top to ceiling to maintain this dimension.)

2 Prepare boiler continued

Vent damper continued

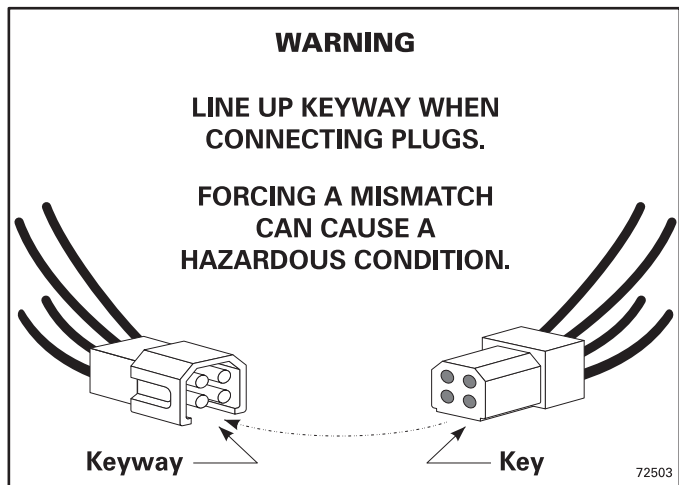
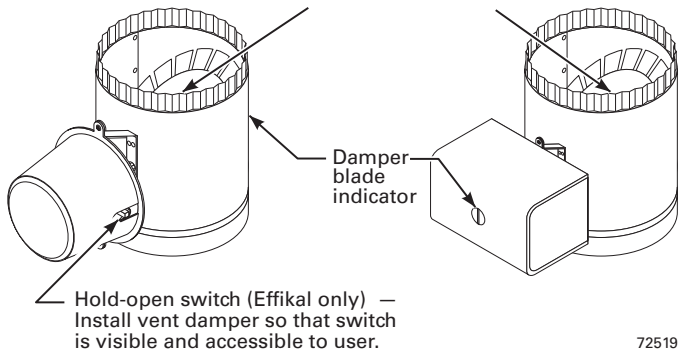

Figure 4 Vent damper assemblies

Effikal or Field Controls damper

Johnson Controls damper

Refer to vent manufacturer's instructions to install plug (shipped with damper) in damper hole.



Damper installation

⚠ DANGER Do not modify draft hood or vent damper, or make another connection between draft hood and vent damper or boiler except as noted below. This will void CSA certification and will not be covered by warranty. Any changes will cause severe personal injury, death or substantial property damage.

1. Install vent damper horizontally or vertically as shown in vent damper manufacturer's instructions. Vent damper must be installed so that it serves only one boiler and so damper blade indicator is visible to the user. See **Figure 4**.
2. Screws or rivets used to secure the vent damper to the draft hood must not interfere with rotation of the damper blade.
3. Install damper harness between damper actuator and hole in jacket left side panel. See **Figure 3, page 8**.

Use strain relief connectors and locknuts to secure both ends of damper harness.

⚠ CAUTION Keep wiring harness clear of all hot surfaces. Wire insulation could be damaged, causing risk of electrical short-circuit.

4. Read and apply the harness plug warning label (shown upper-left) so that it is visible after installation
5. Plug damper harness receptacle into damper harness plug.

⚠ DANGER Bypassing (jumping) vent damper will cause flue products such as carbon monoxide to escape into the house. This will cause severe personal injury or death.

⚠ CAUTION After boiler has operated once, if either end of harness is disconnected, the system safety shutdown will occur. The boiler will not operate until harness is reconnected.

NOTICE Effikal or Field Controls damper — Damper hold open switch must be in Automatic Operation position for system to operate properly.

3 Install water piping

General

If installation is to comply with ASME or Canadian requirements, an additional high temperature limit is needed. Install control in supply piping between boiler and isolation valve. Set second control to minimum 20 °F above setpoint of first control. Maximum allowable setpoint is 240 °F. See **pages 21 & 22** for wiring.

A low water cutoff device is required when boiler is installed above radiation level or by certain state or local codes or insurance companies. Use low water cutoff designed for water installations. Electrode probe-type is recommended. Purchase and install in tee supply piping above boiler.

Use backflow check valve in cold water supply if required by local codes.

Near-boiler piping

See **Table 4** and **Figure 5** (diaphragm-type or bladder-type expansion tank) or **Figure 6** (closed-type expansion tank) on page 11 for near-boiler piping for systems designed for return water at least 130 °F.

See **page 12, (Figures 8 and 9)** for near-boiler piping for low-temperature or high-volume systems.

See **page 11, (Figure 7)** for boilers used with refrigeration systems.

Isolation valves

Isolation valves are required to enable servicing of the boiler's temperature sensor. Install as shown in appropriate piping diagram.

Relief valve

Install relief valve vertically in 3/4" tapping on side of boiler. See the tag attached to the relief valve for manufacturer's instructions.

- WARNING** To avoid water damage or scalding due to valve operation, discharge line must be connected to relief valve outlet and run to a safe place of disposal. Terminate the discharge line to eliminate possibility of severe burns should the valve discharge.
- Discharge line must be as short as possible and be the same size as the valve discharge connection throughout its entire length.
 - Discharge line must pitch downward from the valve and terminate at least 6" above the floor drain where any discharge will be clearly visible.
 - The discharge line shall terminate plain, not threaded, with a material serviceable for temperatures of 375 °F or greater.
 - Do not pipe the discharge to any place where freezing could occur.
 - No shutoff valve shall be installed between the relief valve and boiler, or in the discharge line. Do not plug or place any obstruction in the discharge line.
 - Failure to comply with the above guidelines could result in failure of the relief valve to operate, resulting in possibility of severe personal injury, death or substantial property damage.
 - Test the operation of the valve after filling and pressurizing system by lifting the lever. Make sure the valve discharges freely. If the valve fails to operate correctly, replace it with a new relief valve.

Near-boiler piping continued

Table 4 Water pipe size (based on 20 °F rise)

Boiler model number	To system	From system
GWA-052	3/4"	3/4"
GWA-070	1"	1"
GWA-105	1"	1"
GWA-140	1"	1"
GWA-175	1 1/4"	1 1/4"
GWA-210	1 1/4"	1 1/4"
GWA-245	1 1/2"	1 1/2"

Circulator

The circulator is shipped loose (wiring pre-attached to boiler) to allow you to locate it either in the return or supply piping, as desired. See **page 11** for a typical installation. Pipe the expansion tank to the suction side of the circulator whenever possible. Install an air separator in the supply piping. Connect the expansion tank to the air separator only if the separator is on the suction side of the circulator. Always install the system fill connection at the same point as the expansion tank connection to the system. Figures 5 and 6 show typical near-boiler piping connections.

Expansion tank

Diaphragm-type or bladder-type expansion tank — Figure 5

1. Ensure expansion tank size will handle boiler and system water volume and temperature. Tank must be located in boiler return piping as close to boiler as possible, before inlet side of circulator. See tank manufacturer's instructions for details.
2. Install an automatic air vent as shown.

Closed-type expansion tank — Figure 6

1. Ensure expansion tank size will handle boiler and system water volume and temperature. See tank manufacturer's instructions for details.
2. Connect tank to 1/2" NPT tapping located behind supply outlet, using 1/2" NPT piping. Pitch any horizontal piping up towards tank 1 inch per 5 feet of piping.

CAUTION Undersized expansion tanks cause system water to be lost from relief valve and makeup water to be added through fill valve. Eventual section failure can result.

Water piping — multiple zone systems

Install system piping using either circulator zoning or zone valve zoning. Install expansion tank on suction side of system circulator. Always connect fill line only at the expansion tank — never at another point in the system.

3 Install water piping continued

Near-boiler piping continued

Figure 5 Diaphragm- or bladder-type expansion tank: Piping to single-zone system using diaphragm-type or bladder-type expansion tank. See **Table 4** for piping sizes.

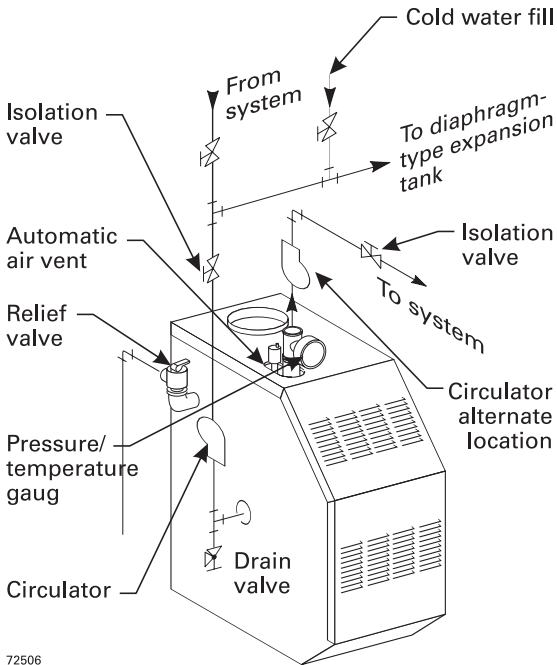

72506

Figure 6 Closed-type expansion tank: Piping to single-zone system using closed-type expansion tank. See **Table 4** for piping sizes.

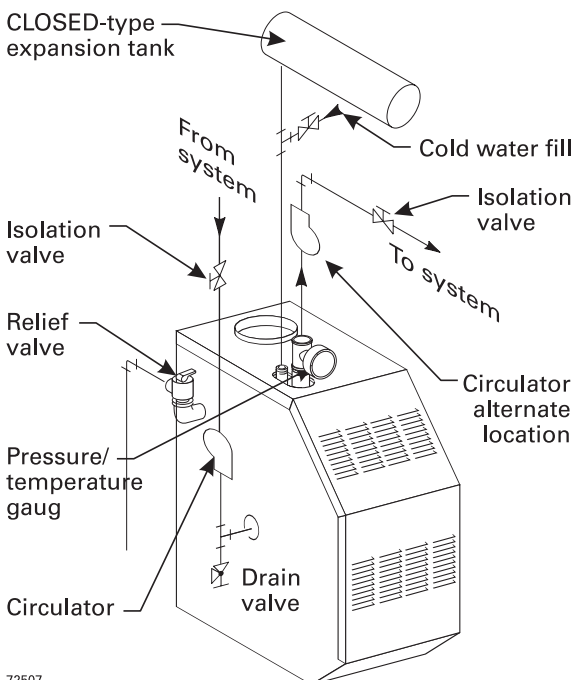

72507

WARNING Use **Figure 5** or **Figure 6** only for systems designed for return water at least 130 °F. For systems with low return water temperature possible, such as converted gravity systems and radiant heating systems, install bypass piping (see **page 12**) to protect boiler against condensation. Failure to prevent low return water temperature to the boiler could cause corrosion of the boiler sections or burners, resulting in severe personal injury, death or substantial property damage.

WARNING If system includes radiant heating circuits, provide piping and controls to regulate the temperature supplying the radiant circuits. Failure to comply could result in substantial property damage.

WARNING Install boiler so that chilled medium is piped in parallel with heating boiler (**Figure 7**). Use appropriate valves to prevent chilled medium from entering boiler. Consult AHRI Installation and Piping Guides.

If boiler is connected to heating coils located in air handling units where they can be exposed to refrigerated air, use flow control valves or other automatic means to prevent gravity circulation during cooling cycle. Circulation of cold water through the boiler could result in damage to the heat exchanger, causing possible severe personal injury, death or substantial property damage.

Water piping — refrigeration systems

Prevent chilled water from entering boiler

Install boiler so that chilled medium is piped in parallel with the heating boiler. Use appropriate valves to prevent chilled medium from entering boiler. See **Figure 7** for typical installation of balancing valve and check valve.

Figure 7 Piping refrigeration systems

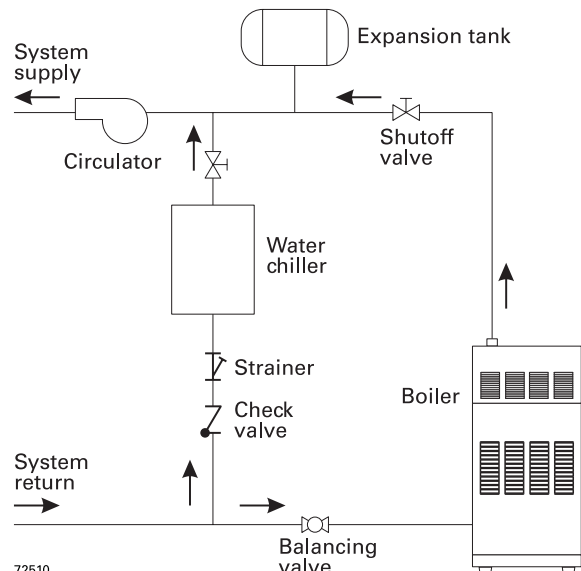

72510

3 Install water piping continued

Near-boiler piping continued

Figure 8 System bypass piping in boiler loop with separate system circulator, using primary/secondary piping.

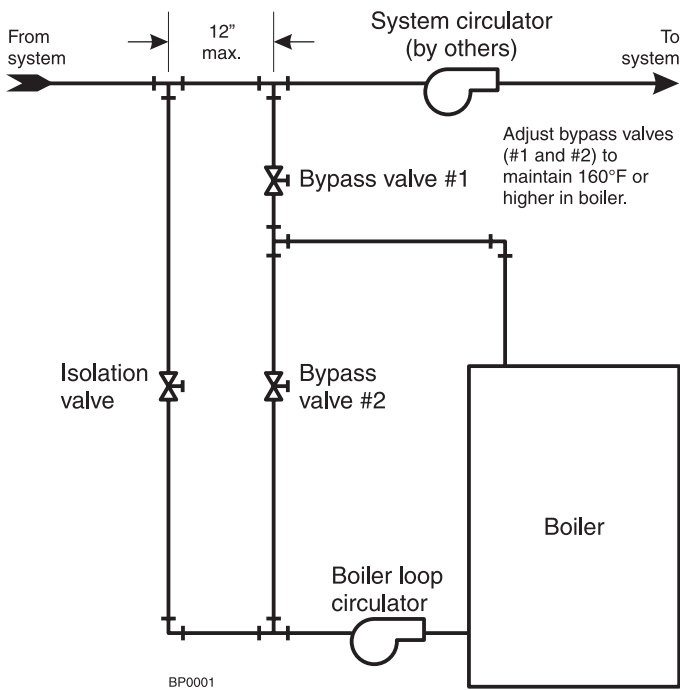
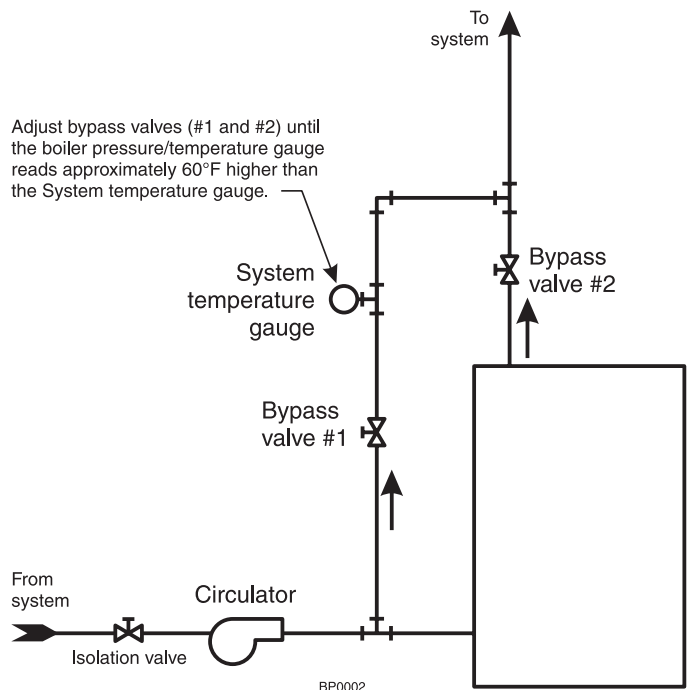

Figure 9 Boiler bypass piping — use only for high water content systems —DO NOT use for radiant panel systems.



System bypass method

1. Apply bypass piping of **Figure 8** to high water content systems, radiant panel systems or any system that is likely to operate with low return water temperature for extended periods.
2. The bypass arrangement shown protects the boiler from damage caused by condensate corrosion due to low return water temperature and protects low temperature systems from too high a supply temperature.
3. Adjust the bypass valves as indicated below.

Adjust Bypass valves 1 and 2 as follows:

1. Start with valve 2 fully closed, valve 1 fully open.
2. Slowly open valve 2 while closing valve 1. Adjust the valves until the boiler pressure/temperature gauge reads 160 °F or higher. As you open the valves, pause long enough to allow temperatures to level off. It takes a while for the boiler water temperature to rise as the flow changes.
3. Bypass valve 2 allows hot boiler outlet water to blend with colder return water, raising the supply temperature to the boiler. Bypass valve 1 balances the pressure drop through valve 2.
4. The purpose of this piping is to raise the return water temperature to the boiler enough to prevent condensation of flue gases.

Boiler bypass method

1. Apply bypass piping of Figure 9 to high water content systems, such as converted gravity systems.
2. The bypass arrangement shown protects the boiler from damage caused by condensate corrosion due to low return water temperature. This method does not provide protection from high temperature water being supplied to the system.
3. DO NOT apply this piping to radiant panel systems.
4. Adjust the bypass valves as indicated below.

Adjust Bypass valves 1 and 2 as follows:

1. Start with valve 1 fully closed, valve 2 fully open.
2. Slowly open valve 1 while closing valve 2. Adjust the valves until the boiler pressure/temperature gauge reads approximately 60 °F higher than the system temperature gauge. As you open the valves, pause long enough to allow temperatures to level off. It takes a while for the boiler water temperature to rise as the flow changes.
3. Bypass valve 1 controls system flow rate. Bypass valve 2 controls flow through the boiler.
4. The purpose of this piping is to cause a high enough temperature rise in the boiler that the average temperature will be warm enough to prevent condensation of flue gases.

WARNING Install all components specified above and adjust valves as described to prevent low temperature in the boiler. Failure to prevent low water temperature in the boiler could cause corrosion of the boiler sections or burners, resulting in severe personal injury, death or substantial property damage.

4 Install gas piping

Connecting gas supply piping to boiler

1. Remove jacket front panel and see Figure 10 to pipe gas to boiler.
 - a. Install drip leg at inlet of gas connection to boiler. Where local utility requires drip leg to be extended to the floor, use appropriate length of nipple between cap and tee.
 - b. Install ground joint union for servicing, when required.
 - c. Install manual shutoff valve in gas supply piping outside boiler jacket when required by local codes or utility requirements.
 - d. In Canada — When using manual main shutoff valve, it must be identified by the installer.
2. Support piping with hangers, not by boiler or its accessories.
3. Purge all air from gas supply piping.
4. Before placing boiler in operation, check boiler and its gas connection for leaks.
 - a. Close manual main shutoff valve during any pressure testing at less than 13" w.c.
 - b. Disconnect boiler and gas valve from gas supply piping during any pressure testing greater than 13" w.c.

WARNING Do not check for gas leaks with an open flame — Use bubble test. Failure to use bubble test or check for gas leaks can cause severe personal injury, death or substantial property damage.

5. Use pipe dope compatible with propane gases. Apply sparingly only to male threads of pipe joints so that pipe dope does not block gas flow.

WARNING Failure to apply pipe dope as described in this manual can result in severe personal injury, death or substantial property damage.

Table 5 Pipe capacity for 0.60 specific gravity natural gas

Gas pipe length (feet)	Capacity of pipe for pipe size of: (Capacity in standard cubic feet gas per hour)				
	½"	¾"	1"	1¼"	1½"
10	132	278	520	1050	1600
20	92	190	350	730	1100
30	73	152	285	590	860
40	63	130	245	500	760
50	56	115	215	440	670
75	45	93	175	360	545
100	38	79	150	305	460
150	31	64	120	250	380

Natural Gas:

1. See **Table 5** for pipe length and diameter. Base on rated boiler input (divide by 1,000 to obtain cubic feet per hour). Table 5 is only for gas with specific gravity 0.60, with a pressure drop through the gas piping of 0.30" w.c. For additional gas pipe sizing information, see ANSI Z223.1 (B149.1 or B149.2 for Canadian installations).
2. Inlet pressure required at gas valve inlet:
 - Maximum: 13" w.c.
 - Minimum: 5" w.c.
 - Manifold gas pressure: 3.5" w.c.
3. Install 100% lockup gas pressure regulator in supply line if inlet pressure exceeds 13" w.c. Adjust for 13" w.c. maximum.

Propane Gas:

1. Contact gas supplier to size pipes, tanks and 100% lockup gas pressure regulator.
2. Adjust propane supply regulator provided by gas supplier for 13" w.c. maximum pressure.
3. Inlet pressure required at gas valve inlet:
 - Maximum: 13" w.c.
 - Minimum: 11" w.c.
 - Manifold gas pressure: 10" w.c.

Figure 10 Gas supply piping

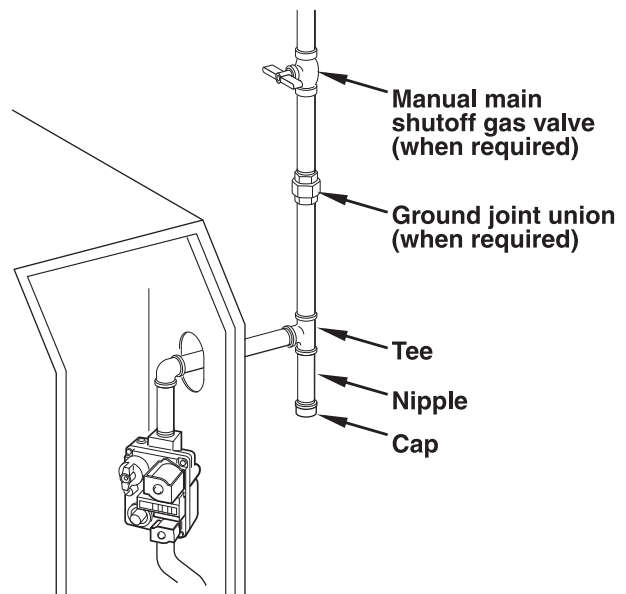

72511

5 Field wiring

WARNING For your safety, turn off electrical power supply at service entrance panel before making any electrical connections to avoid possible electric shock hazard. Failure to do so can cause severe personal injury or death.

NOTICE Wiring must be N.E.C. Class 1. If rollout thermal fuse element wire as supplied with boiler must be replaced, type 200 °C wire or equivalent must be used. If other original wiring as supplied with boiler must be replaced, use only type 105 °C wire or equivalent. Boiler must be electrically grounded as required by National Electrical Code ANSI/NFPA 70—latest edition.

Electrical installation must comply with:

1. National Electrical Code and any other national, state, provincial or local codes or regulations.
2. In Canada, CSA C22.1 Canadian Electrical Code Part 1, and any local codes.

Wiring connections

Boiler is shipped with controls completely wired, except spill switch and vent damper. See wiring diagram on pages 21 & 22 for spark-ignited pilot boiler. Circulator is shipped loose, but wiring harness is pre-attached to the boiler. Connect wires in circulator junction box.

Thermostat

1. Connect thermostat as shown on wiring diagram on boiler.
2. Install on inside wall away from influences of drafts, hot or cold water pipes, lighting fixtures, television, sun rays or fireplaces.
3. If thermostat has a heat anticipator, set heat anticipator in thermostat to match power requirements of equipment

connected to it. If connected directly to boiler, set for 0.4 amps. For other devices, see manufacturer’s specifications. Wiring diagram on boiler gives setting for control module and gas valve. Also see instructions with thermostat.

DHW (if used)

Connect DHW aquastat as shown in wiring below. Economy function isn’t utilized with DHW input.

R & C Connections (if used)

24 Vac leads should be used for power stealing thermostats only!

Junction box (furnished)

1. Connect 120 VAC power wiring (Figure 11).
2. Fused disconnect or service switch (15 amp. recommended) may be mounted on this box. For those installations with local codes which prohibit installation of fused disconnect or service switch on boiler, install a 2 x 4 cover plate on the boiler junction box and mount the service switch remotely as required by the code.

Wiring multiple zones

See zone valve manufacturer’s literature for wiring and application. A separate transformer is required to power zone valves. Zoning with circulators requires a relay for each circulator.

CAUTION DO NOT connect directly from 3-wire zone valves to the T-T terminals on the boiler. When using 3-wire zone valves, install an isolation relay. Connect the zone valve end switch wires to the isolation relay coil. Connect the isolation relay contact across the boiler T-T terminals. Failure to comply can result in damage to boiler components or cause unreliable operation, resulting in severe property damage.

Figure 11 Field wiring connections — service switch, DHW (if used) and thermostat (or end switch) provided by installer.

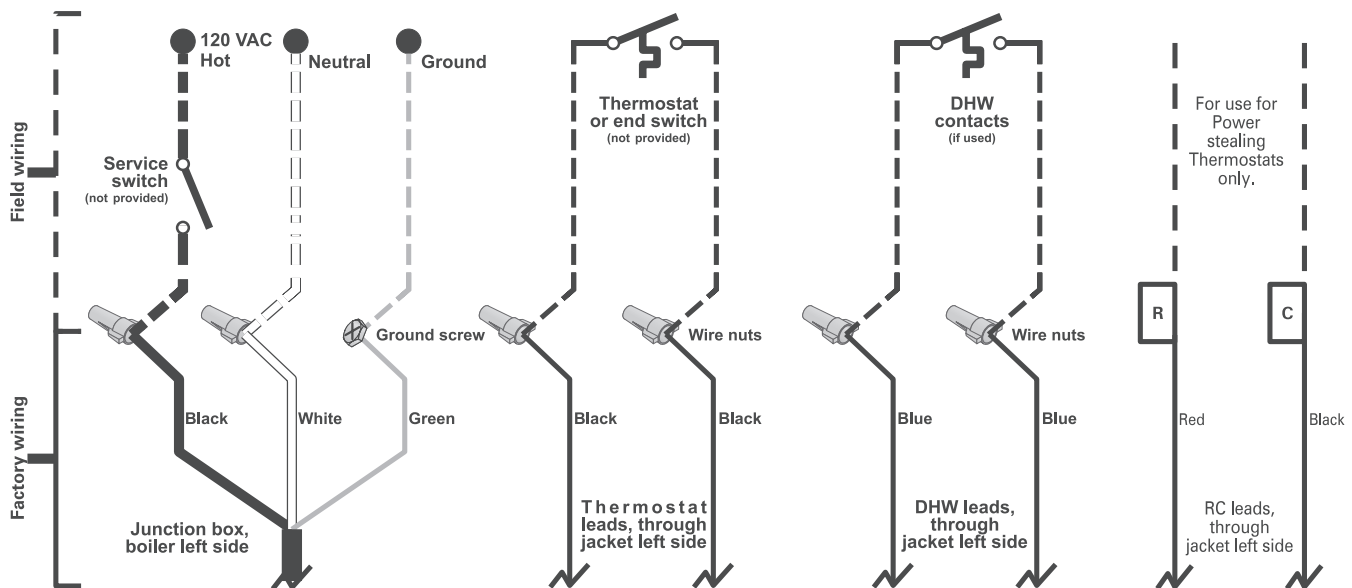

NOTICE Boiler circulator is shipped loose, with wiring harness connected and wired to boiler. After circulator is piped, connect wires to circulator and secure harness conduit connector to circulator junction box.

WD0001

6 Start-up

Preparation

Check for gas leaks

▲WARNING Before starting the boiler, and during initial operation, smell near the floor and around the boiler for gas odorant or any unusual odor. Do not proceed with start-up if there is any indication of a gas leak. Repair any leak at once.

▲WARNING Propane boilers only — Your propane supplier mixes an odorant with the propane to make its presence detectable. In some instances, the odorant can fade and the gas may no longer have an odor.

- Propane gas can accumulate at floor level. Smell near the floor for the gas odorant or any unusual odor. If you suspect a leak, do not attempt to light the pilot.
- Use caution when attempting to light the propane pilot. This should be done by a qualified service technician, particularly if pilot outages are common.
- Periodically check the odorant level of your gas.
- Inspect boiler and system at least yearly to make sure all gas piping is leak-tight.
- Consult your propane supplier regarding installation of a gas leak detector. There are some products on the market intended for this purpose. Your supplier may be able to suggest an appropriate device.

Determine if water treatment is needed

▲DANGER Do not use petroleum-based cleaning or sealing compounds in boiler system. Severe damage to boiler will occur, resulting in substantial property damage.

▲WARNING Eliminate all system leaks. Continual fresh makeup water will reduce boiler life. Minerals can build up in sections, reducing heat transfer, overheating cast iron, and causing section failure.

Verify water chemistry

Consult local water treatment companies for unusually hard water areas (above 7 grains hardness) or low pH water conditions (below 7.0). Boiler water pH of 7.0 to 8.5 is recommended.

Freeze protection (when used)

Use antifreeze made especially for hydronic systems. Inhibited propylene glycol is recommended.

▲WARNING Do not use ethylene glycol, automotive or undiluted antifreeze. Severe personal injury or death can result.

1. Determine antifreeze quantity according to system water content. Boiler water content is listed on **Page 46**. Remember to include expansion tank water content.
2. Follow antifreeze manufacturer's instructions.
3. A 50% solution of propylene glycol/water provides maximum protection to about -30 °F.
4. Local codes may require back flow preventer or actual disconnect from city water supply.
5. When using antifreeze in a system with automatic fill, install a water meter to monitor water makeup. Glycol will leak before the water begins to leak, causing glycol level to drop. Added water will dilute the antifreeze, reducing the freeze protection level.

Fill the system with water

1. Close manual and automatic air vents and boiler drain cock.
2. Fill to correct system pressure. Correct pressure will vary with each application. Typical cold water fill pressure for a residential system is 12 psi.
3. Purge air from system:
 - a. Connect a hose to purge valve or valves, if installed. Route hose to an area where water can drain and be seen.
 - b. Close the boiler or system isolation valve between the purge valve and fill connection to the system.
 - c. Close zone isolation valves.
 - d. Open quick-fill valve on cold water makeup line.
 - e. Open purge valve.
 - f. One zone at a time, open the isolation valves. Allow water to run through the zone, pushing out the air. Run until no noticeable air flow is present. Close the zone isolation valves and proceed with the next zone. Follow this procedure until all zones are purged.
 - g. Close the quick-fill water valve and purge valve and remove the hose. Open all isolation valves. Watch that system pressure rises to correct cold-fill pressure.
 - h. After the system has operated for a while, eliminate any residual air by using the manual air vents located throughout the system.
 - i. If purge valves are not installed in system, open manual air vents in system one at a time, beginning with lowest floor. Close vent when water squirts out. Repeat with remaining vents.
4. Open automatic air vent (diaphragm-type or bladder-type expansion tank systems only) one turn.
5. Open other vents:
 - a. Starting on the lowest floor, open air vents one at a time until water squirts out.
 - b. Repeat with remaining vents.
6. Refill to correct pressure.

Inspect system water piping

After filling the boiler and system with water, inspect all piping throughout the system for leaks. If found, repair immediately. Repeat this inspection after the boiler has been started and the system has heated up.

▲WARNING Leaks must be repaired at once. Failure to do so can damage the boiler, resulting in substantial property damage.

▲DANGER Do not use petroleum-based cleaning or sealing compounds in boiler system. Severe damage to boiler will occur, resulting in substantial property damage.

Inspect base insulation

▲WARNING The boiler contains ceramic fiber and fiberglass materials. Use care when handling these materials per instructions on **page 39** of this manual. Failure to comply could result in severe personal injury.

Check to make sure insulation is secure against all four sides of the base. If insulation is damaged or displaced, do not operate boiler. Replace or reposition insulation.

▲WARNING Failure to replace damaged insulation or reposition insulation can result in a fire hazard, causing severe personal injury, death or substantial property damage.

6 Start-up continued

Operate boiler

⚠ WARNING DO NOT proceed with boiler operation unless boiler and system have been filled with water and all instructions and procedures of previous manual sections have been completed. Failure to do so could result in severe personal injury, death or substantial property damage. Before starting the boiler . . .

- See manual **Section 10** for spark-ignited pilot “**Operating Instructions**” procedure (see **Table 6**, below).
- Verify the boiler and system are full of water (or glycol/water mixture, if used).
- Verify the “Preparation” procedures of **page 15** have been completed.

Table 6 Operating instruction locating guide

GWA Spark-ignited pilot	Page
Honeywell VR8204/VR8304 White-Rodgers 36C White-Rodgers 36E	23
Robertshaw 7200	24

Adjust boiler control settings

BOILER OPERATING TEMPERATURE

With power turned on, control module receives a signal from the temperature sensor. The control knob labeled **BOILER TEMP** is used to adjust the operating temperature setpoint, turning clockwise to increase temperature setting and counterclockwise to decrease.

- **ADJUST BOILER OPERATING TEMPERATURE TO DESIRED SETPOINT.**

BOILER ECONOMY SETTING

To comply with Department of Energy regulations, the control module circulates available hot water before turning on the boiler to attempt to satisfy a call for heat. While attempting to satisfy the heat demand, the control module also monitors the boiler temperature changes via the temperature sensor and determines whether or not the available hot water will satisfy the demand, adjusting the time delay to turn on the boiler until it determines that additional heat will be needed. The knob labeled **ECONOMY ADJUST** provides an adjustment between maximize (MAX) and minimize (MIN) the delay. The maximum (MAX) adjustment position should be used to maximize energy savings. Turning the knob counterclockwise decreases the delay time and should only be used in the event that the heated space becomes uncomfortable.

- **ADJUST ECONOMY TO DESIRED POSITION (MAX IS THE PREFERRED SETTING).**



IMPORTANT

In accordance with Section 325 (f) (3) of the Energy Policy and Conservation Act, this boiler is equipped with a feature that saves energy by reducing the boiler water temperature as the heating load decreases. This feature is equipped with an override which is provided primarily to permit the use of an external energy management system that serves the same function.

THIS OVERRIDE MUST NOT BE USED UNLESS AT LEAST ONE OF THE FOLLOWING CONDITIONS IS TRUE:

- An external energy management system is installed that reduces the boiler water temperature as the heating load decreases.
- This boiler is part of a modular or multiple boiler system having a total input of 300,000 BTU/hr or greater.
- This boiler is equipped with a tankless coil.

Start the boiler

Follow the “*Operating Boiler Instructions*” from:

- Spark-ignited pilot boilers — See **Section 10**.

Remove boiler jacket door and note the gas valve manufacturer and model number.

If boiler fails to start, see “If boiler doesn’t start . . . Check for:” on this page.

Check system and boiler

⚠ WARNING Eliminate all system leaks. Continual fresh makeup water will reduce boiler life. Minerals can build up in sections, reducing heat transfer, overheating cast iron, and causing section failure.

⚠ WARNING If you discover evidence of any gas leak, shut down the boiler at once. Find the leak source with bubble test and repair immediately. Do not start boiler again until corrected. Failure to comply could result in severe personal injury, death or substantial property damage.

⚠ DANGER Do not use petroleum-based cleaning or sealing compounds in boiler system. Severe damage to boiler will occur, resulting in substantial property damage.

1. Check system piping for leaks. If found, shut down boiler and repair immediately.

6 Start-up continued

Verify operation

- Vent air from system using manual vents. Air in the system will interfere with circulation and cause heat distribution problems and noise.
- Inspect vent system thoroughly for signs of deterioration from corrosion, physical damage or sagging. Verify that masonry chimney liners are in good condition, with no obstructions, and there are no openings into the chimney.
- Check around the boiler for gas odor following the procedure of “Check for gas leaks”, **page 15**.
- Verify operation using procedures below. Perform “Checkout procedure”, **page 18**, and fill in the “Installation and service certificate”.

If boiler doesn't start . . . Check for:

- Loose connections, blown fuse or service switch off?
- Boiler temperature adjustment, set below boiler water temperature?
- Thermostat set below room temperature?
- Gas not turned on at meter or boiler?
- Incoming gas pressure less than:
5" w.c. for natural gas? 11" w.c. for propane gas?
- If none of the above corrects the problem, see “Troubleshooting”, **Section 12, page 29**.

NOTICE

Check the pilot ignition system used for the boiler. The boiler model suffix will contain an “I” for spark-ignited pilot. See **Section 10** for spark-ignited pilot “Operating Instructions”.

Check burner flame — Pilot burner

Proper pilot flame (see **Figure 12**):

- Blue flame.
- Inner cone engulfing pilot flame sensor (spark-ignited pilot).
- Pilot flame sensor glowing cherry red.

Improper pilot flame:

- Overfired — Large flame lifting or blowing past pilot flame sensor.
- Under fired — Small flame. Inner cone not engulfing pilot flame sensor.
- Lack of primary air — Yellow flame tip.
- Incorrectly heated pilot flame sensor.

Check burner flames — Main burner

Proper main burner flame (see **Figure 13**):

- Yellow-orange streaks may appear (caused by dust).

Improper main burner flame:

- Overfired — Large flames.
- Under fired — Small flames.
- Lack of primary air — Yellow tipping on flames (sooting will occur).

Figure 12 Typical pilot burner flame

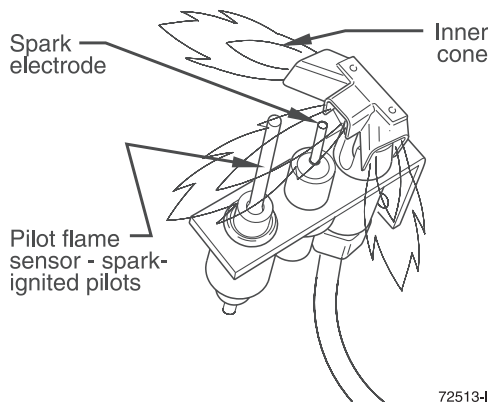
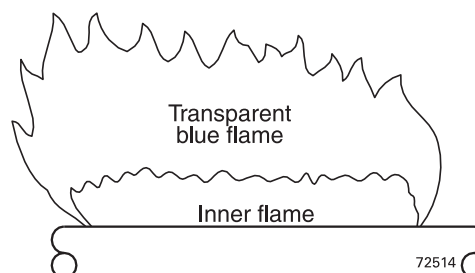

Figure 13 Typical main burner flame



Check vent damper operation

- Raise room thermostat to call for heat — Vent damper actuator will slowly open vent damper.
- When vent damper is fully open** — Pilot will light, then allow main burners to ignite.

⚠ DANGER

Vent damper must be fully open before main burners light. If vent damper does not fully open, flue products such as carbon monoxide will escape into house, causing severe personal injury or death.

- Lower thermostat setting — Main burner flames will go out, then vent damper will close.
- Repeat Steps 2 through 4 several times to verify operation.
- Return thermostat to normal setting.
- Set thermostat heat anticipator setting indicated on wiring diagram.

Check venting system operation

- With boiler firing, hold a candle or match below lower edge of draft hood “skirt.” If flame does not blow out, but burns undisturbed, the vent system is working properly. If flame blows out or flickers severely, the vent system must be checked for obstructions or other causes of improper venting.

7 Checkout procedure

- Boiler and heat distribution units filled with water?
- Automatic air vent, if used, open one full turn?
- Air purged from system?
- Air purged from gas piping? Piping checked for leaks?
- Correctly-sized manifold orifices installed? See **Table 3, page 6**, to check size and fuel type.

⚠ DANGER Correctly sized manifold orifices must be used. Failure to do so will cause severe personal injury, death or substantial property damage.

- Followed “Operating Instructions” on boiler or in Manual **Section 10, pages 23 & 24** for proper start-up?
- Proper burner flame observed? See “Verify operation”, Manual **Section 6, page 17**.
- Test temperature limit — While burners are operating, turn Boiler Temp adjustment knob counterclockwise until setting is below actual boiler water temperature. Burners should go off while circulator continues to operate. Turn Boiler Temp Adjustment knob clockwise until setting is above boiler water temperature and ignition sequence should resume.
- Test additional field-installed controls — If boiler has a low water cutoff, additional high limit or other controls, test for operation as outlined by manufacturer. Burners should be operating and should go off when controls are tested. When controls are restored, burners should reignite.
- Button on spill switch pushed in?
- Test ignition system safety device:

Spark-ignited pilot — Connect manometer to outlet side of gas valve. Start boiler, allowing for normal start-up cycle to occur and main burners to ignite. With main burners on, manually shut off gas supply at manual main shutoff gas valve. Burners should go off. Open manual main shutoff gas valve. Manometer should confirm there is no gas flow. Pilot will relight, flame sensing element will sense pilot flame and main burners reignite.

- Set Boiler Temp adjustment knob to system temperature requirements. Adjust balancing valves and controls to provide design temperature to system.
- Set Economy mode, fully clockwise.
- For multiple zones, adjust flow so it is about the same in each zone.
- Verify thermostat heat anticipator (if available) set properly? See “Field wiring”, Manual **Section 5, page 14**, “Thermostat”.
- Cycle boiler with thermostat — Raise to highest setting and verify boiler goes through normal start-up cycle. Lower to lowest setting and verify boiler goes off.
- Cycle DHW Aquastat if used.
- Measure natural gas input:
 - a. Operate boiler 10 minutes.
 - b. Turn off other appliances.
 - c. At natural gas meter, measure time (in seconds) required to use one cubic foot of gas.
 - d. Calculate gas input:

$$\frac{3600 \times 1000}{\text{number of seconds from step c}} = \text{Btuh}$$
 - e. Btuh calculated should approximate input rating on boiler rating label.
- Check manifold gas pressure by connecting manometer to downstream test tapping on main gas valve. Manifold pressure for natural gas should be 3.5" w.c. and for propane gas should be 10" w.c.
- Observe several operating cycles for proper operation.
- Set room thermostat to desired room temperature.
- Fill in Installation and service certificate below?
- Review all instructions shipped with this boiler with owner or maintenance person. Return instructions to envelope and give to owner.

Installation and service certificate

Boiler model _____ Series _____

CP number _____ Date installed _____

Measured Btuh input _____

- Installation instructions have been followed.
- Checkout sequence has been performed.
- Above information is certified to be correct.
- Information received and left with owner/maintenance person.

Installer _____ (company) _____ (address) _____ (phone)

(installer's signature)

8 Department of Energy – Compliance

This boiler is equipped with a control system that automatically adjusts a time delay period to turn on the boiler during a call for heat. This is accomplished by circulating available hot water in the system while measuring water boiler water temperature changes. The control calculates a suitable delay based on temperature measurements and turns the boiler on only after it determines that the demand for heat cannot be satisfied with the available hot water,

Due to the wide variety of controls used in boiler installations, this control is also equipped with an adjustment for the calculated time delay period (ECONOMY ADJUST). In the MIN position, the time delay is zero and the IMPORTANT notice below must be observed:

IMPORTANT

In accordance with Section 325 (f) (3) of the Energy Policy and Conservation Act, this boiler is equipped with a feature that saves energy by reducing the boiler water temperature as the heating load decreases. This feature is equipped with an override which is provided primarily to permit the use of an external energy management system that serves the same function.

THIS OVERRIDE MUST NOT BE USED UNLESS AT LEAST ONE OF THE FOLLOWING CONDITIONS IS TRUE:

- An external energy management system is installed that reduces the boiler water temperature as the heating load decreases.
- This boiler is part of a modular or multiple boiler system having a total input of 300,000 BTU/hr or greater.
- This boiler is equipped with a tankless coil.

9 Sequence of operation – spark-ignited pilot boilers

NOTICE

Follow all procedures given in this manual and operating instructions when operating the boiler. Failure to do so could result in severe personal injury, death or substantial property damage.

1. **Standby:** With no call for heat, the vent damper and circulator are de-energized. No gas flows to pilot or main gas valve.
2. **Call for heat** (thermostat circuit closes):
 - a. While attempting to satisfy the heat demand, the control module monitors the boiler temperature changes via the temperature sensor and determines whether or not the available hot water will satisfy the demand, only running the circulator. If additional heat is needed, the sequence continues. When DHW (if used) calls for heat, sequence above is bypassed.
 - b. Vent damper and circulator energized if pilot status acceptable. Vent damper drives open. When vent damper end switch makes circuit, ignition control begins pilot ignition attempt.
 - c. Ignition control checks for false flame signal: If ignition control senses pilot signal when no pilot gas should be present, control will lockout, requiring reset procedure as given in **Figure 14, page 20**.
3. **Pilot ignition:** Control module sparks the pilot and opens pilot valve in main gas valve.
 - a. If pilot does light and control module senses flame current, spark generator is turned off and main valve opens.
 - b. **Natural Gas** - If pilot does not light within 15 seconds, pilot valve is closed and spark generator is turned off. Control module waits 5 minutes, then attempts to ignite pilot again. This cycle will continue indefinitely if pilot ignition control does not sense pilot flame.
 - c. **Propane Gas** - If pilot does not light within 15 seconds, pilot valve is closed and spark generator is turned off. Control module waits 1 minute then attempts to ignite pilot again. After first failed ignition retry attempt, control module will attempt to ignite pilot 2 more times with a 5 minute wait period after the second try and a 60 minute wait period after the third try. If the ignition control does not sense pilot flame during these trials, it will lock out the boiler and require a manual reset procedure to allow further attempts.

Manual Reset Procedure for Propane Gas Lockout —

⚠ DANGER

Unburned propane gas may have accumulated in combustion chamber. Provide adequate ventilation to completely remove any accumulated LP gas from boiler and adjacent area before attempting to reset and light boiler. Failure to do so will cause severe personal injury, death or substantial property damage.

9 Sequence of operation – spark-ignited pilot boilers

Propane Gas Lockout manual reset – **ONLY** after boiler area has been cleared of any accumulated LP gas:

- Push and hold **TEST** button.
- While holding **TEST** button, rotate **Economy Adjust** knob fully clockwise then fully counter clockwise.
- Release **TEST** button.
- Control module is **reset**.

4. Main burner operation:

- a. Control module monitors pilot flame current. If signal is lost, main valve closes, spark generator activates and sequence returns to step 4.
- b. If power is interrupted, control system shuts off pilot and main gas valves and restarts at step 1 when power is restored.

- c. In the event the limit control shuts down the boiler — The control module closes the main gas valve, but keeps the circulator operating and the vent damper open.

5. **Thermostat satisfied** (thermostat circuit opens) — Pilot and main gas valves are closed — Vent damper is de-energized, and cycles to closed position. Circulator is shut off.
6. Boiler is now in the standby mode.
7. Thermostat anticipator setting: Set thermostat heat anticipator as instructed in **Figure 15b, page 22**.

Figure 14 Ignition control module sequence of operation – status light indications

Steps (following step 7, cycle goes back to step 1.)	Call for heat?	POWER 	TSTAT CIRC 	LIMIT 	DAMPER 	FLAME 	TIMING
1. Standby • Waiting for call for heat	NO						—
2. Call for heat • Circulator on	YES						—
3. Limit circuit • Limit controls closed	YES						—
4. Damper circuit • Damper proven open	YES						—
5. Pilot flame proven * • Gas valve open • Pilot remains on • Boiler producing heat	YES						15 sec
6. Limit cycle • Limit circuit open	YES						—
7. Flame outage • Flame out • Boiler recycles	YES						—
8. Thermostat satisfied • Circulator off	NO						15 sec
9. Circulator exercise routine • Circulator turns on for 30 seconds if boiler not operated for 30 days	NO						30 sec
		= "ON" = "OFF"					
<p>* See Section 9, Items 3b for control response to failure to proven pilot flame.</p> <p>Control will lockout under the following conditions:</p> <ul style="list-style-type: none"> • Line voltage polarity is reversed • Stray voltage is sensed on thermostat line • Damper end switch not proven within 5 minutes from thermostat call for heat • Flame is sensed when it shouldn't be there <p>Control will reset after these lockouts if any of the following occur</p> <ul style="list-style-type: none"> • 1 hour waiting period • Opening and closing of thermostat circuit for 2 to 20 seconds 							

59340 GWA

9 Sequence of operation – spark-ignited pilot boilers

Figure 15a Schematic wiring diagram — Spark-ignited pilot system

CAUTION

DO NOT connect directly from 3-wire zone valves to the T-T terminals on the boiler. When using 3-wire zone valves, install an isolation relay. Connect the zone valve end switch wires to the isolation relay coil. Connect the isolation relay contact across the boiler T-T terminals. Failure to comply can result in damage to boiler components or cause unreliable operation, resulting in possible severe property damage.

NOTICE

- The control module is polarity-sensitive to the incoming 120 VAC power. If polarity is reversed, control will flash the **POWER** light when powered and will not cycle boiler.
- All contacts shown without power applied.
- Connector and status light locations/orientations may vary.

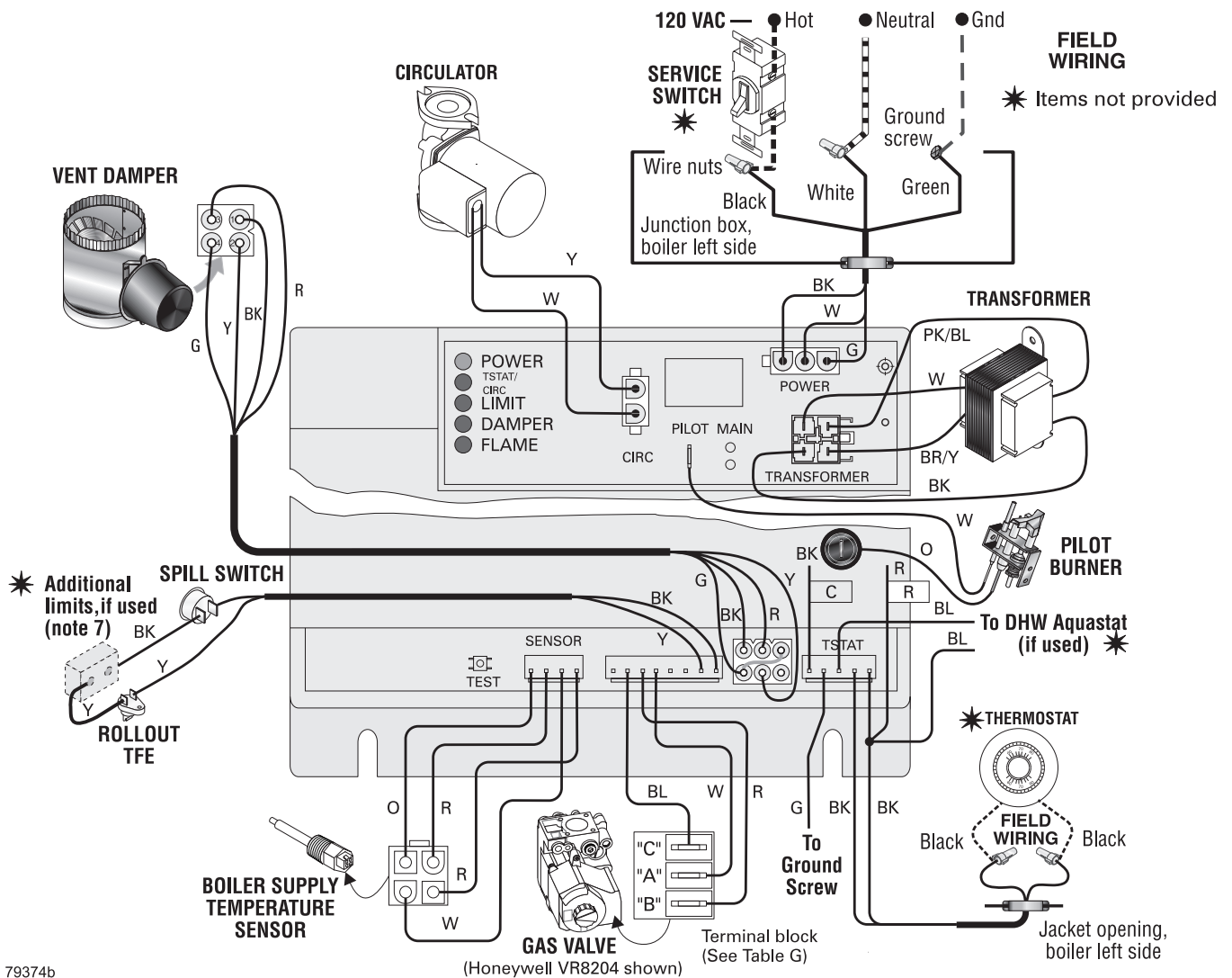

79374b

9 Sequence of operation – spark-ignited pilot boilers

Figure 15b Schematic wiring diagram — Spark-ignited pilot system

WARNING **Electrical shock hazard** — can cause severe injury or death. Disconnect power before installing or servicing.

Legend for ladder wiring diagram	
	120 VAC field wiring
	Low voltage field wiring
	120 VAC factory wiring
	Low voltage factory wiring
	High voltage spark ignition wiring
	Ground connectors

Table G: Gas valve terminals and anticipator settings

Gas valve	"A"	"B"	"C"	Anticipator amps
Honeywell VR8204	MV/PV	MV	PV	0.6
Honeywell VR8304	MV/PV	MV	PV	0.8
White-Rodgers 36E	2	1	3	0.64
White-Rodgers 36C	2-4 *	1	3	0.7

* Terminals 2-4 are factory-jumpered on the White-Rodgers 36C gas valve.

- All wiring must be installed in accordance with:
 - U.S.A. — N.E.C. And any other national, state, or local code requirements.
 - Canada — C.S.A. C22.1 C.E.C. Part 1 and any other national, provincial, or local code requirements.
- Pilot lead wires are not field replaceable. Replace pilot assembly if necessary.
- If any of the original wire as supplied with the appliance must be replaced, use minimum 105 °C wire or equivalent. Exception — wires to a rollout TFE must be 200 °C or equivalent.
- Thermostat anticipator setting (single zone) — see Table G for anticipator setting, depending on which gas valve is installed in boiler.
- For multiple zoning, use either zone valves or circulators. Refer to the component manufacturer's instructions and this manual for application and wiring suggestions.
- Refer to control component instructions packed with the boiler for application information.
- Wire any additional limit controls (low water cut-off, additional high limit, etc.) in series with boiler rollout TFE and spill switch as shown.

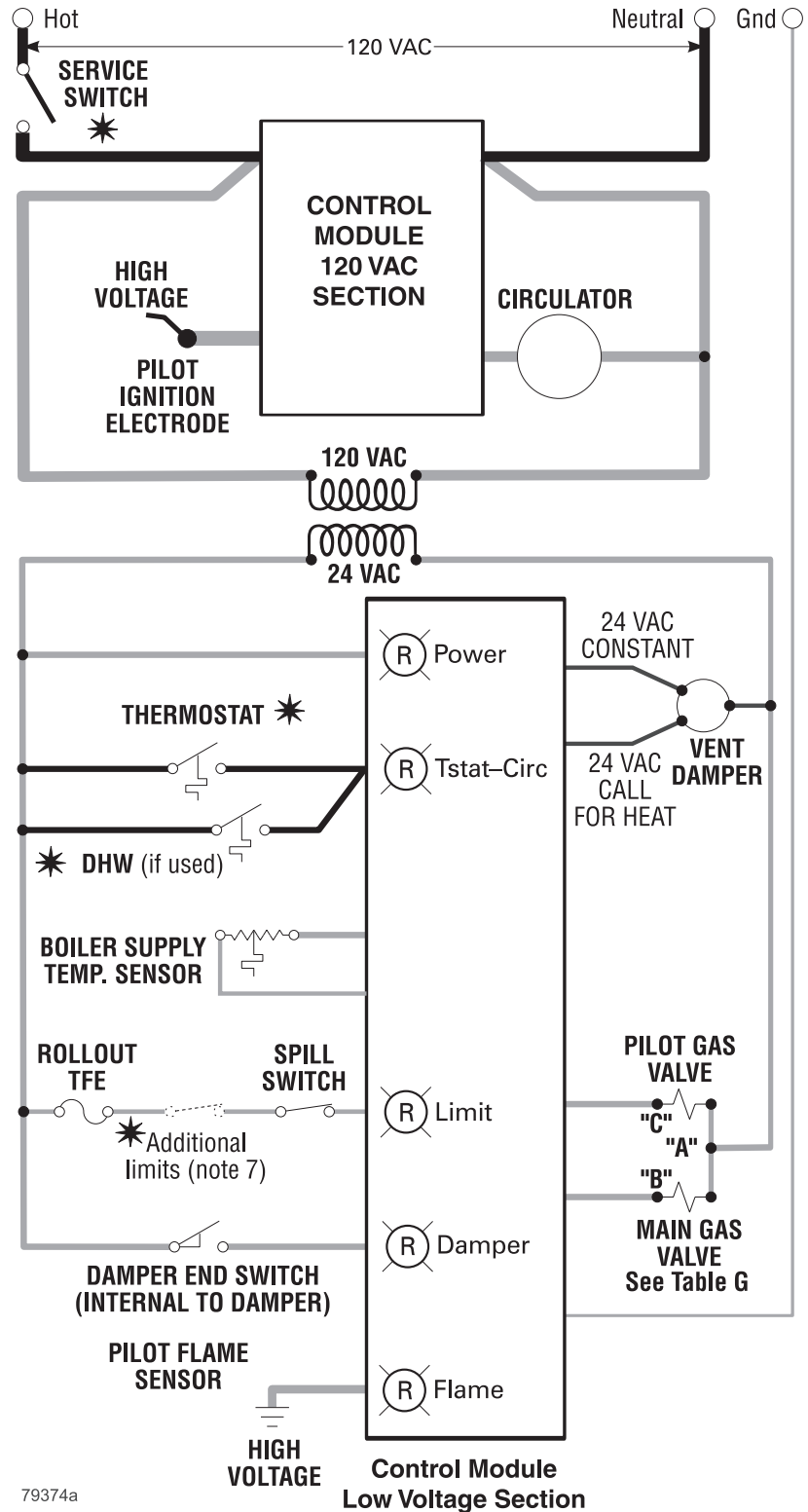

79374a

10 Operating instructions – spark-ignited pilot boilers

Gas valve – Honeywell VR8204 or VR8304 – White-Rodgers 36C or 36E

FOR YOUR SAFETY READ BEFORE OPERATING

WARNING If you do not follow these instructions exactly, a fire or explosion may result causing property damage, personal injury or loss of life.

- A. This appliance is equipped with an ignition device which automatically lights the pilot. **Do not** try to light the pilot by hand.
- B. Before **OPERATING**, smell all around the appliance area for gas. Be sure to smell next to the floor because some gas is heavier than air and will settle on the floor. See below.
- C. Use only your hand to depress or move the selector arm. Never use tools. If the selector arm will not depress or move by hand, don't try to repair it, call a qualified service technician. Force or attempted repair may result in a fire or explosion.
- D. Do not use this appliance if any part has been under water. Immediately call a qualified service technician to inspect the appliance and to replace any part of the control system and any gas control, which has been under water.

WHAT TO DO IF YOU SMELL GAS

- Do not try to light any appliance.
- Do not touch any electric switch; do not use any phone in your building.
- Immediately call your gas supplier from a neighbor's phone. Follow the gas supplier's instructions.
- If you cannot reach your gas supplier, call the fire department.

OPERATING INSTRUCTIONS

1. **Stop!** Read the safety information above on this label. Vent damper operations below apply only to GWA boilers. Find vent damper manufacturer and model on vent damper nameplate.
2. Set the thermostat to lowest setting.
3. When equipped with **Effikal** vent damper **Model RVGP**, place service switch in **Hold Damper Open** position.
4. Turn off all electrical power to the appliance.
5. When equipped with **Johnson Controls** vent damper **Model M35**, manually rotate damper blade in direction of arrow to **Open** position indicated on damper assembly.
6. This appliance is equipped with an ignition device which automatically lights the pilot. **Do not** try to light the pilot by hand.
7. Turn gas control knob clockwise ↻ to **OFF**. (Press down on White-Rodgers 36C valve knob to turn.)
8. When equipped with vent damper, verify damper blade is in full open position.
9. Wait five (5) minutes to clear out any gas. Then smell for gas, including near the floor. If you smell gas, **STOP!** Follow "**B**" in the safety information above. If you don't smell gas, go to the next step.
10. Turn gas control knob counterclockwise ↶ to **ON**. (Press down on White-Rodgers 36C valve knob to turn.)
11. Turn on all electric power to the appliance.
12. When equipped with **Effikal** vent damper, place service switch in **Automatic Operation** position.
13. Set thermostat to desired setting.
14. If the appliance will not operate, follow the instructions **To Turn Off Gas To The Appliance** and call your service technician or gas supplier.
15. Replace front panel.

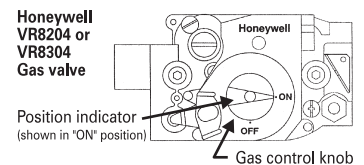
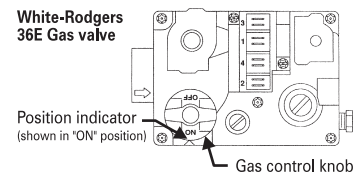
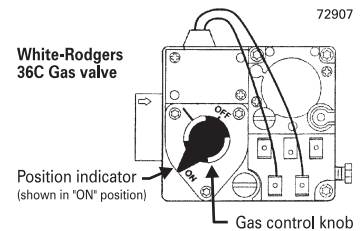

TO TURN OFF GAS TO THE APPLIANCE

1. Set the thermostat to lowest setting.
2. Turn off all electric power to the appliance if service is to be performed.
3. Remove front panel.
4. Turn gas control knob clockwise ↻ to **OFF**. Do not force. (Press down on 36C valve knob to turn.)
5. Replace front panel.

10 Operating instructions – spark-ignited pilot boilers

Gas valve – Robertshaw 7200

FOR YOUR SAFETY READ BEFORE OPERATING

WARNING If you do not follow these instructions exactly, a fire or explosion may result causing property damage, personal injury or loss of life.

- A. This appliance is equipped with an ignition device which automatically lights the pilot. Do not try to light the pilot by hand.
- B. BEFORE OPERATING, smell all around the appliance area for gas. Be sure to smell next to the floor because some gas is heavier than air and will settle on the floor. See below.
- C. Use only your hand to depress or move the selector arm. Never use tools. If the selector arm will not depress or move by hand, don't try to repair it, call a qualified service technician. Force or attempted repair may result in a fire or explosion.
- D. Do not use this appliance if any part has been under water. Immediately call a qualified service technician to inspect the appliance and to replace any part of the control system and any gas control, which has been under water.

WHAT TO DO IF YOU SMELL GAS

- Do not try to light any appliance.
- Do not touch any electric switch; do not use any phone in your building.
- Immediately call your gas supplier from a neighbor's phone. Follow the gas supplier's instructions.
- If you cannot reach your gas supplier, call the fire department.

OPERATING INSTRUCTIONS

1. STOP! Read the safety information above on this label.
2. Set the thermostat to lowest setting.
3. Turn off all electrical power to the appliance.
4. Remove front panel.
5. This appliance is equipped with an ignition device which automatically lights the pilot. Do not try to light the pilot by hand.
6. Depress and move selector arm left ↶ to "OFF." Note: Selector arm cannot be moved to "OFF" unless selector arm is depressed slightly. Do not force.
7. Wait five (5) minutes to clear out any gas. Then smell for gas, including near the floor. If you smell gas, STOP! Follow "B" in the safety information above. If you don't smell gas, go to the next step.
8. Move selector arm right ↷ to "ON."
9. Turn on all electric power to the appliance.
10. Set thermostat to desired setting.
11. If the appliance will not operate, follow the instructions "To Turn Off Gas To The Appliance" and call your service technician or gas supplier.
12. Replace front panel.

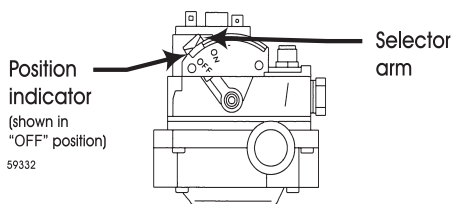

TO TURN OFF GAS TO THE APPLIANCE

1. Set the thermostat to lowest setting.
2. Turn off all electric power to the appliance if service is to be performed.
3. Remove front panel.
4. Depress and move selector arm to "OFF." Do not force.
5. Replace front panel.

550-223-044(0511)

11 Service and maintenance

Table 6 Service and maintenance schedules (service technician and owner)

Service technician (see following pages for instructions)		Owner maintenance (see User's Information Manual for instructions)	
ANNUAL START-UP	<input type="checkbox"/> Inspect: <ul style="list-style-type: none"> • Reported problems • Boiler area • Air openings • Flue gas vent system • Pilot and main burner flames • Water piping • Boiler heating surfaces • Burners, base and inlet air box 	<input type="checkbox"/> Daily <ul style="list-style-type: none"> • Check boiler area • Check boiler pressure/temperature gauge • Check air openings 	
	<input type="checkbox"/> Service: <ul style="list-style-type: none"> • Oiled-bearing circulators • Temperature sensor 	<input type="checkbox"/> Monthly <ul style="list-style-type: none"> • Check boiler piping • Check venting system • Check boiler relief valve • Check automatic air vents (if used) • Check pilot and main burner flames 	
	<input type="checkbox"/> Start-up: <ul style="list-style-type: none"> • Perform start-up per manual 	<input type="checkbox"/> Periodically <ul style="list-style-type: none"> • Test low water cutoff (if used) 	
	<input type="checkbox"/> Check/test: <ul style="list-style-type: none"> • Gas piping • Cold fill and operating pressures • Air vents and air elimination • Limit controls and cutoffs • Expansion tank • Boiler relief valve 	<input type="checkbox"/> Every 6 months <ul style="list-style-type: none"> • Operate relief valve 	
	<input type="checkbox"/> Review: <ul style="list-style-type: none"> • Review with owner 	<input type="checkbox"/> End of season <ul style="list-style-type: none"> • Shut down procedure 	

⚠ WARNING Follow the “Service and maintenance” procedures given throughout this manual and in component literature shipped with the boiler. See “Read this first” on **page 2**. Failure to perform the service and maintenance could result in damage to the boiler or system. Failure to follow the directions in this manual and component literature could result in severe personal injury, death or substantial property damage.

11 Service and maintenance continued

⚠ WARNING The boiler should be inspected and started annually, at the beginning of the heating season, only by a qualified service technician. In addition, the maintenance and care of the boiler designated in **Table 6, page 25** and explained on the following pages must be performed to assure maximum boiler efficiency and reliability. Failure to service and maintain the boiler and system could result in equipment failure.

⚠ WARNING Electrical shock hazard — Turn off power to the boiler before any service operation on the boiler except as noted otherwise in this manual. Failure to turn off electrical power could result in electrical shock, causing severe personal injury or death.

⚠ WARNING The boiler contains ceramic fiber and fiberglass materials. Use care when handling these materials per instructions on **page 39** of this manual. Failure to comply could result in severe personal injury.

□ Inspect

Reported problems

Inspect any problems reported by owner and correct before proceeding.

Boiler area

1. Verify that boiler area is free of any combustible materials, gasoline and other flammable vapors and liquids.
2. Verify that boiler area (and air intake) is free of any of the contaminants listed in **Table 2 on page 5** of this manual. If any of these are present in the boiler intake air vicinity, they must be removed. If they cannot be removed, install combustion air piping to the boiler in accordance with national, provincial or local codes.

Air openings

1. Verify that combustion and ventilation air openings to the boiler room and/or building are open and unobstructed. Check operation and wiring of automatic combustion air dampers, if used.
2. Verify that boiler vent discharge and air intake are clean and free of obstructions.

Flue gas vent system

1. Visually inspect entire flue gas venting system for blockage, deterioration or leakage. Repair any joints that show signs of leakage in accordance with vent manufacturer's instructions.
2. Verify that masonry chimneys are lined, lining is in good condition, and there are not openings into the chimney.

⚠ WARNING Failure to inspect for the above conditions and have them repaired can result in severe personal injury or death.

Pilot and main burner flames

1. Visually inspect pilot burner and main burner flames as directed under **Section 6, page 17** of this manual.

□ Inspect

Water piping

1. Check the boiler interior piping and all system piping for signs of leaks.
2. Repair any leaks before proceeding.

⚠ DANGER Do not use petroleum-based cleaning or sealing compounds in boiler system. Severe damage to boiler will occur, resulting in substantial property damage.

⚠ WARNING Eliminate all system or boiler leaks. Continual fresh makeup water will reduce boiler life. Minerals can build up in sections, reducing heat transfer, overheating cast iron, and causing section failure. Leaking water may also cause severe property damage.

Boiler heating surfaces

1. Disconnect the vent pipe at the boiler draft hood and remove draft hood after turning off power to the boiler.
2. Use a bright light to inspect the boiler flue collector and heating surfaces.
3. If the vent pipe or boiler interior surfaces show evidence of soot, follow "Cleaning boiler heating surfaces" in this manual section, **page 28**. Remove the flue collector and clean the boiler if necessary after closer inspection of boiler heating surfaces.
4. If there is evidence of rusty scale deposits on boiler surfaces, check the water piping and control system to make sure the boiler return water temperature is properly maintained (per this manual).
5. Reconnect vent and draft hood. Replace all boiler components before returning to service.
6. Check inside and around boiler for evidence of any leaks from the boiler. If found, locate source of leaks and repair.

Burners and base

1. After turning off power to the boiler, remove the jacket door and base access panel (**Figure 19, item 4, page 40**).
2. Inspect burners and all other components in the boiler base.
3. If burners must be cleaned, raise rear of each burner to release from support slot, slide forward and remove. Then brush and vacuum the burners thoroughly, making sure all ports are free of debris. Carefully replace all burners, making sure burner with pilot bracket is replaced in its original position and all burners are upright (ports up).
4. Inspect the base insulation.

⚠ WARNING The boiler contains ceramic fiber and fiberglass materials. Use care when handling these materials per instructions on page 39 of this manual. Failure to comply could result in severe personal injury.

- a. Verify that the insulation is intact and secure against all four sides of the base.

⚠ WARNING If insulation is damaged or displaced, do not operate the boiler. Replace or reposition insulation as necessary. Failure to replace damaged insulation can result in a fire hazard, causing severe personal injury, death or substantial property damage.

11 Service and maintenance continued

□ Service

Oiled-bearing circulators

1. The circulator shipped with the GWA boiler is water-lubricated. No oiling is required.
2. Check other circulators in the system. Oil any circulators requiring oil, following circulator manufacturer's instructions. Over-oiling will damage the circulator.

Temperature sensor

1. The temperature sensor may accumulate deposits on the probe surface. Annual inspection and cleaning of the probe will improve boiler performance.
Disconnect power, unplug harness from sensor.
 - a. Drain boiler water to a level below the sensor.
 - b. Remove sensor from boiler.
 - c. Wipe any built up contaminants from probe and insulator surfaces.
 - d. Reinstall sensor into boiler. Do not overtighten.

□ Start-up

1. Perform start-up procedures **Section 6, pages 15–17**, including “Verify operation” of burners and vent damper on **page 17**.
2. Verify cold fill pressure is correct and that fill system is working properly.
3. Verify antifreeze level (if used) is at the right concentration and that inhibitor level is correct.
4. Check gas piping, per Manual **Section 4, page 13** and **Section 6, page 15**, verifying no indications of leakage and all piping and connections are in good condition.
5. Read and start the boiler following the “Operating Instructions” (Manual **Section 9 and 10, pages 19 through 24**).

□ Check/test

Gas piping

1. Sniff near floor and around boiler area for any indication of a gas leak.
2. Test gas piping using bubble test, per **Section 4, page 13** of this manual, if there is any indication of a leak.

Cold fill and operating pressures

1. While the system is cold, note the pressure reading on the boiler pressure/temperature gauge. Verify that cold fill pressure is correct.
2. Watch the pressure as the boiler and system heat up to ensure pressure rise is normal. Too high a rise would indicate a waterlogged or undersized expansion tank.

□ Check/test

Air vents and air elimination

1. Inspect automatic air vents (if used). Also inspect air separators to ensure they are operational.
2. The cap must be unscrewed one turn to allow air to escape.
3. If the air vent is leaking, remove cap and briefly push valve — then release to clean the valve seat.
4. Replace cap by twisting all the way onto valve and then unscrewing one turn.

Limit controls and cutoffs

1. Inspect and test the boiler limit control. Verify operation by turning control set point below boiler temperature. Boiler should cycle off. Return dial to original setting.
2. Inspect and test additional limit controls or low water cutoffs installed on system.

Expansion tank

1. Expansion tanks provide space for water to move in and out as the heating system water expands due to temperature increase or contracts as the water cools. Tanks may be open, closed or diaphragm or bladder type. See Section 3, page 10 of this manual for suggested locations of expansion tanks and air eliminators.

Open-type — located above highest radiator or baseboard unit, usually in the attic or closet. Has a gauge glass and overflow pipe to a drain.

Closed-type — welded gas tight and located above boiler. Tank is partially filled with water, leaving an air cushion for expansion.

- Make sure this type of tank is fitted with a tank fitting, such as the B & G Tank-Trol or Taco Taco-Trol. This fitting reduces gravity circulation of air-saturated tank water back to the system and prevents the air from bubbling up through the water as it returns from the system.
- Do not use automatic air vents in systems with closed-type tanks. The air will escape from the system instead of returning to the tank. Eventually, the tank will waterlog and no longer control pressurization. The boiler relief valve will weep frequently.

11 Service and maintenance continued

☐ Check/test. continued

Diaphragm- or bladder-type — welded gas tight with a rubber membrane to separate the tank pressurizing air and the water. May be located at any point in the system, but most often found near the boiler.

- Systems with this type of expansion tank require at least one automatic air vent, preferably located on top of an air eliminator, as shown in examples in Manual **Section 3, page 10**.

2. If relief valve has tended to weep frequently, the expansion tank may be waterlogged or undersized.

Closed-type tank — tank is most likely waterlogged. Install a tank fitting if not already installed. Then check fill level per fitting manufacturer's instructions. If fill level is correct, check tank size against manufacturer's instructions. Replace with a larger tank if necessary.

Diaphragm- or bladder-type — first, check tank size to be sure it is large enough for the system. If size is too small, add additional tank(s) as necessary to provide sufficient expansion. If tank size is large enough, remove tank from system and check charge pressure (usually 12 psig for residential applications). If tank won't hold pressure, membrane has been damaged. Replace tank.

Boiler relief valve

1. Inspect the relief valve and lift the lever to verify flow as in the following warnings, excerpted from a relief valve manufacturer's warning label. Before operating any relief valve, ensure that it is piped with its discharge in a safe area to avoid severe scald potential. Read Manual **Section 3, page 10**, before proceeding further.

⚠ WARNING Safety relief valves should be reinspected AT LEAST ONCE EVERY THREE YEARS, by a licensed plumbing contractor or authorized inspection agency, to ensure that the product has not been affected by corrosive water conditions and to ensure that the valve and discharge line have not been altered or tampered with illegally. Certain naturally occurring conditions may corrode the valve or its components over time, rendering the valve inoperative. Such conditions are not detectable unless the valve and its components are physically removed and inspected. This inspection must only be conducted by a plumbing contractor or authorized inspection agency — not by the owner. Failure to reinspect the boiler relief valve as directed could result in unsafe pressure buildup, which can result in severe personal injury, death or substantial property damage.

⚠ WARNING Following installation, the valve lever must be operated AT LEAST ONCE A YEAR to ensure that waterways are clear. Certain naturally occurring mineral deposits may adhere to the valve, rendering it inoperative. When manually operating the lever, water will discharge and precautions must be taken to avoid contact with hot water and to avoid water damage. Before operating lever, check to see that a discharge line is connected to this valve directing the flow of hot water from the valve to a proper place of disposal otherwise severe personal injury may result. If no water flows, valve is inoperative. Shut down boiler until a new relief valve has been installed.

2. After following the preceding warning directions, if the relief valve weeps or will not seat properly, replace the relief valve. Ensure that the reason for relief valve weeping is the valve and not over-pressurization of the system due to expansion tank waterlogging or under sizing.

☐ Review with owner

1. Review the User's Information Manual with the owner.
2. Emphasize the need to perform the maintenance schedule specified in the User's Information Manual (and in this manual as well).
3. Remind the owner of the need to call in a licensed contractor should the boiler or system exhibit any unusual behavior.
4. Remind the owner to follow the proper shutdown procedure and to schedule an annual start-up at the beginning of the next heating season.

☐ Cleaning boiler heating surfaces

⚠ WARNING The boiler contains ceramic fiber and fiberglass materials. Use care when handling these materials per instructions on **page 39** of this manual. Failure to comply could result in severe personal injury.

1. Shut down boiler:
 - Follow "To Turn Off Gas to Appliance" instructions on boiler and "Operating Instructions".
 - Do not drain boiler unless it will be exposed to freezing temperatures. If using antifreeze in system, do not drain.
2. Follow shutdown procedure.
3. Remove venting system connection to boiler.
4. Remove top jacket panel. Turn back insulation.
5. Remove flue collector. Clean sealant from assembly and sections.
6. Remove radiation plates hanging between sections.
7. Remove burners from base. Brush and vacuum burners to remove all dust and lint. Verify that all burner ports are free of debris.
8. Place newspapers in base of boiler to collect soot.
9. Clean between sections with wire flue brush.
10. Remove newspaper and soot. Vacuum or brush base and surrounding area.
11. Reinstall radiation plates.
12. Replace collector box/transition assembly. Seal with sealant. Obtain gas-tight seal to prevent flue gas spillage and carbon monoxide emissions, resulting in severe personal injury or death.
13. Replace insulation and jacket top panel.
14. Start up boiler following **Section 6, pages 15–17** of this manual and the boiler "Operating Instructions", **pages 23 and 24**. Excessive sooting indicates improper gas combustion. If found, check for proper combustion and make any necessary adjustments.

12 Troubleshooting

▲WARNING Label all wires prior to disconnection when servicing controls. Wiring errors can cause improper and dangerous operation.

▲WARNING Never jumper (bypass) rollout thermal fuse element or any other device except for momentary testing as outlined in **Troubleshooting Charts**. Severe personal injury, death or substantial property damage can result.

▲WARNING Burner access panel must be in position during boiler operation to prevent momentary flame rollout on ignition of main flame. Severe personal injury or substantial property damage will result.

Before troubleshooting:

1. Have the following items:
 - a. Voltmeter that can check 120 VAC and 24 VAC.
 - b. Microammeter with a scale range of 0-10.
 - c. Continuity checker.
 - d. U-tube manometer.
2. Check for 120 VAC (minimum 102 VAC to maximum 132 VAC) to boiler.
3. Make sure thermostat is calling for heat and contacts (including appropriate zone controls) are closed. Check for 24 VAC between thermostat wire nuts and ground.

Troubleshooting sequence:

1. Before proceeding, check for:
 - Loose connections, blown fuse or service switch off?
 - Boiler temperature adjustment, set below boiler water temperature?
 - Thermostat set below room temperature?
 - Gas not turned on at meter or boiler?
 - Incoming gas pressure less than:
 - 5" w.c. for natural gas? 11" w.c. for propane gas?
2. If all of the above check correctly, check gas pressures:
 - a. With boiler off
 - 13" w.c. maximum natural or propane gas pressure upstream of gas valve.
 - b. With boiler on:
 - 5" w.c. minimum natural gas pressure or 11" w.c. propane gas pressure upstream of gas valve.
 - 3.5" w.c. minimum natural gas pressure or 10" w.c. propane gas pressure downstream tapping on gas valve — Can be adjusted by regulator on gas valve.
 - c. If gas pressure is incorrect or gas is not available to boiler, contact gas supplier to correct before proceeding further.
3. Check pilot operation - Follow "Operating Instructions", **pages 23 and 24**.
 - If gas is available and you cannot obtain a pilot flame, try purging the gas line and cleaning pilot and pilot gas tubing. Follow "Operating Instructions" again.

In event of vent damper failure:

Effikal or Field Controls vent damper

If troubleshooting chart recommends replacing actuator and actuator is not immediately available, damper blade can be fixed in an open position to allow boiler operation. Manually turning blade can cause actuator damage. Follow these instructions only in case of no heat or damper actuator malfunction.

1. Move damper service switch to Hold Damper Open position. Apply call for heat to boiler. Damper blade should then rotate to Open position and boiler will fire.
2. If step 1 does not open damper, manually rotate damper blade to open position using wrench or pliers on flat shaft between damper and actuator. Boiler will fire. Verify that damper service switch is in Hold Damper Open position. **(Figure 15)**
3. Do not leave vent damper permanently in this position. Replace actuator immediately. If vent damper is left in Open position, boiler will not operate at published efficiencies.

Johnson Controls vent damper

If troubleshooting chart recommends replacing actuator and actuator is not immediately available, damper blade can be fixed in an open position to allow boiler operation. Follow these instructions only in case of no heat or damper actuator malfunction. See **Figure 15**.

1. Turn off power to boiler.

▲WARNING Failure to turn off power to boiler can result in severe personal injury, death or substantial property damage.

2. See vent damper manufacturer's instructions for procedure to fix vent damper in open position.
3. Turn on power to boiler.
4. Using wrench or pliers on flat shaft section, manually rotate damper blade until green light turns on. Boiler will fire. **(Figure 15)**
5. Do not leave vent damper permanently in this position. Replace actuator immediately. If vent damper is left in Open position, boiler will not operate at published efficiencies.

Figure 15 Manually opening vent damper

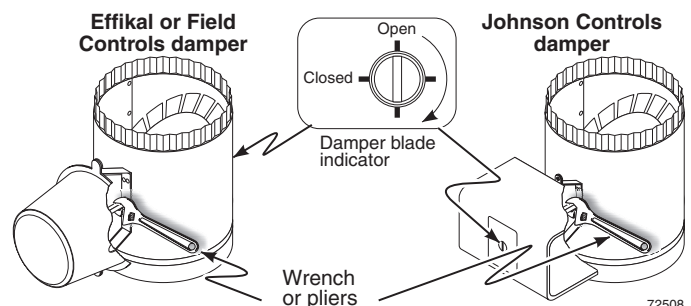

▲WARNING Verify proper operation after servicing. • See vent damper manufacturer's instructions packed with vent damper for additional information. Failure to comply could result in severe personal injury, death or substantial property damage.

12 Troubleshooting – spark-ignited pilot boilers

Temperature sensor

1. The boiler temperature sensor is a resistance-type device.
2. The Chart below shows the correct value for the sensor at various temperatures.
3. Use the resistance values at 32°F, 60°F, 70°F and 212°F to measure the sensor resistance at known temperatures (ice point, room temperature and sea level boiling point). For ice point and boiling point, insert the sensor in water at that temperature. Use an ohmmeter to read resistance value between thermistor # and thermistor common. See Figure 30, page 50, for sensor plug details.

Sensor resistance values

Sensor resistance values					
Temp (°F)	Sensor ohms		Temp (°F)	Sensor ohms	
	Min	Max		Min	Max
32	34265	37871	120	4517	4992
40	27834	30764	130	3698	4088
50	21630	23907	140	3043	3364
60	16944	18727	150	2517	2782
70	13372	14780	160	2091	2311
80	10629	11747	170	1744	1928
90	8504	9399	180	1461	1615
100	6847	7568	190	1229	1359
110	5545	6129	200	1038	1147

NOTICE

The information on this page and pages 31 through 38 apply only to spark-ignited pilot GWA boilers. These boilers are equipped with an ignition control module that has indicator lights to show control status. See **Charts 1 through 6, pages 32-38**, help you identify problems based on indicator light conditions.

Figure 16 GWA Ignition control module



Control module

WARNING

Solder or water splatter between plugs and circuit board can cause improper operation of control module. Place a shield over the boiler internal controls and components during installation. Failure to comply could result in severe personal injury, death or substantial property damage.

NOTICE

Make sure **ground wiring** is installed per wiring diagram. Good grounding is extremely important for proper operation.

12 Troubleshooting – spark-ignited pilot boilers

Control indicator lights –

HARD LOCKOUT Summary (Flashing LED's)

MAY remove 120 VAC power for more than 2 seconds to clear lockout OR ignition control will automatically restart sequence of operation after 1 hour waiting period after fault condition is cleared.

INDICATOR LIGHT	CONDITION
POWER	
Flashes once per second	120 VAC connection to boiler reversed.
Flash code 2*	Internal fault, microprocessor or memory.
Flash code 3*	Unused.
Flash code 4*	Unused.
Flash code 5*	Internal fault, water thermistors disagree.
Flash code 6*	Internal fault, gas valve circuit.
* Flash code pattern: POWER LED flashes 2, 3, etc. times rapidly followed by 2 seconds off, then repeats.	
ALL LED'S FLASHING	Failure to establish pilot flame after 4 attempts. Follow Manual
(Propane Gas Only)	Reset Procedure on page 19 and 20 to correct.

SOFT LOCKOUT Summary (Flashing LED's)

MAY remove 120 VAC power for more than 2 seconds, cycle thermostat for between 2 and 20 seconds, OR ignition control will automatically restart sequence of operation after 1 hour waiting period.

INDICATOR LIGHT	CONDITION
POWER + TSTAT/CIRC	High voltage detected on TSTAT circuit.
POWER + DAMPER	Damper stuck closed or unable to close end switch within 45 seconds from TSTAT call.
POWER + FLAME	Flame sensed without call for heat or out of sequence during ignition trial.

CAUTION Summary (Flashing LED's)

INDICATOR LIGHT	CONDITION
DAMPER	Damper end switch opened after it had been proven closed.
LIMIT	Fault detected in temperature sensing hardware.
FLAME	Flame loss or flame not sensed during trial for ignition.

Troubleshooting the control module

See **Figure 17**, page 32, for location of harness plug receptacles and plugs on the control module.

12 Troubleshooting – spark-ignited pilot boilers

Figure 17 Control module connections

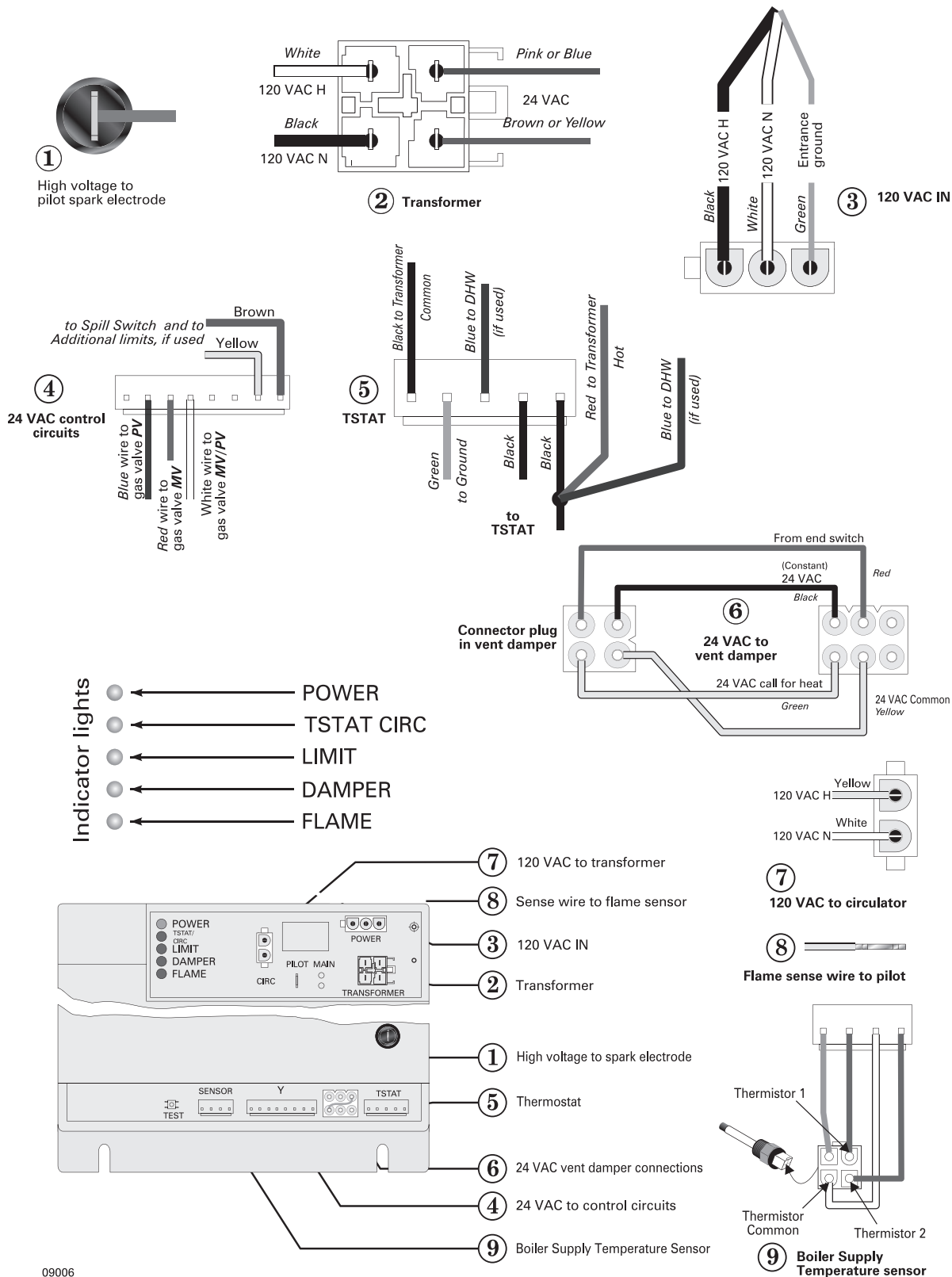

09006

12 Troubleshooting – Spark-ignited pilot boilers

CHART 1 — Spark-ignited pilot — Troubleshooting POWER light status

— Usually indicates reversed 120 VAC polarity if POWER light flashes by itself —



Electrical shock hazard — Wherever you see **▲ TURN OFF POWER ▲**, follow the instructions. Failure to follow instructions could result in severe personal injury, death or substantial property damage.

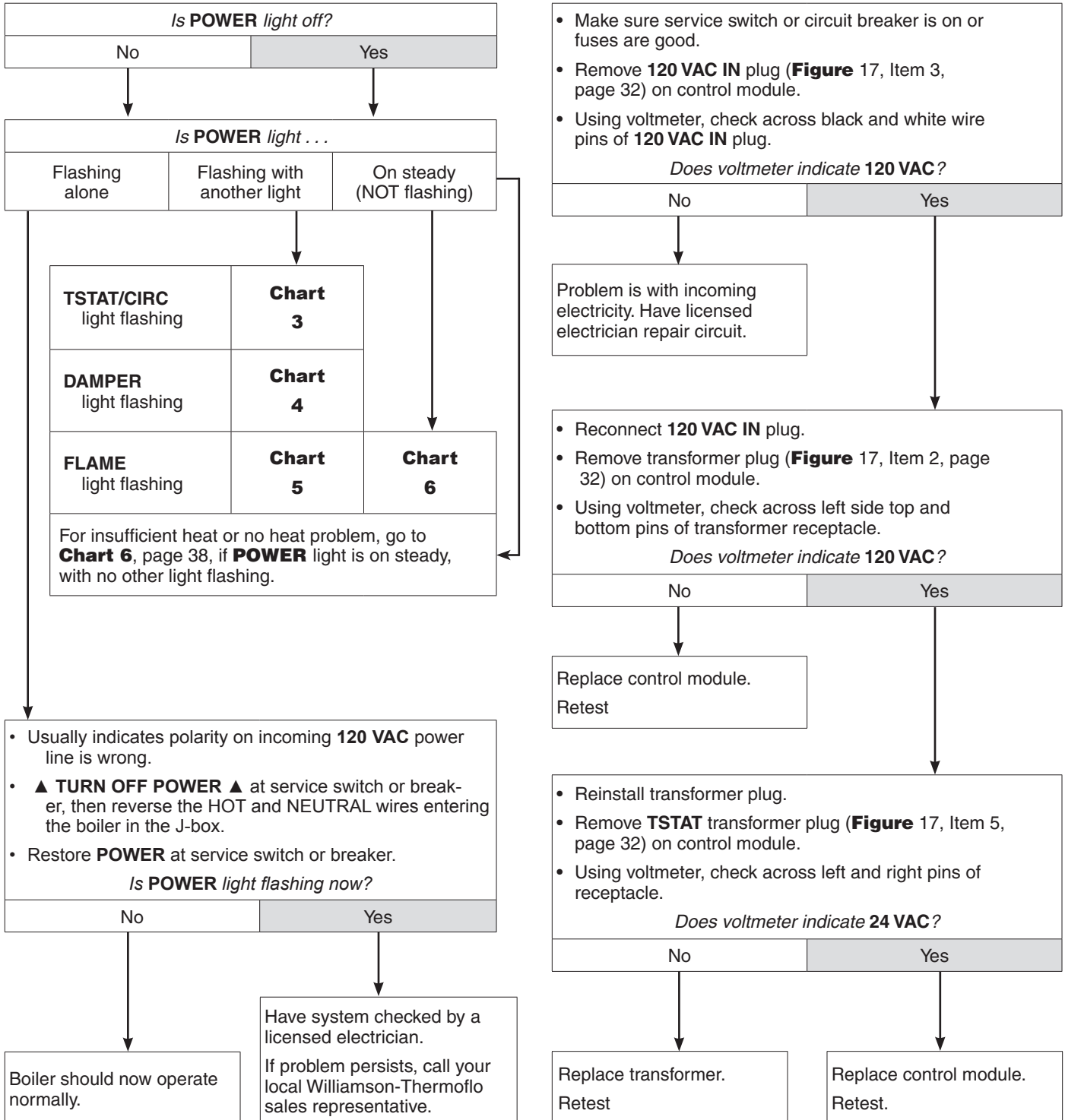

12 Troubleshooting – spark-ignited pilot boilers

CHART 2 — Spark-ignited pilot — TSTAT CIRC & POWER lights flashing

— Usually indicates 48 VAC on thermostat circuit (stray voltage) —



Electrical shock hazard — Wherever you see ▲ **TURN OFF POWER** ▲, follow the instructions. Failure to follow instructions could result in severe personal injury, death or substantial property damage.

- Disconnect the two external wires connected to the boiler thermostat leads (two black low voltage leads in J-box).
- Connect a voltmeter across these two incoming wires. Close each thermostat, zone valve and relay in the external circuit one at a time and check the voltmeter reading across the wires.
- There should NEVER be a voltage reading.
- If a voltage does occur under any condition, check and correct the external wiring. (This is a common problem when using 3-wire zone valves).
- Once the external thermostat circuit wiring is checked and corrected if necessary, reconnect the external thermostat circuit wires to the boiler thermostat wires and allow the boiler to cycle.

Did you find a voltage across the two external thermostat circuit wires ?

Yes

No

- Leave external boiler thermostat connection wires disconnect from boiler.
- Troubleshoot the external thermostat circuit until you find the source of the stray voltage. (Pay close attention to the wiring connections to 3-wire zone valves).
- Correct the problem and repeat the voltmeter test above, verifying there is no longer a voltage reading under any condition in the external thermostat circuit.

- If no voltage is found under any condition on the external thermostat circuit, connect the two boiler thermostat connection leads together (or jumper the boiler aquastat T-T terminals).
- Turn off power to the boiler for 1 minute.
- Turn on power and allow boiler to cycle.

Do the TSTAT and POWER lights still flash ?

No

Yes

- Boiler should now operate per normal sequence of operation shown in **Figure 14**, page 20.

- Replace control module.
- Retest.

12 Troubleshooting – spark-ignited pilot boilers

CHART 3 — Spark-ignited pilot — DAMPER light flashing

- If **POWER** light is flashing: Usually indicates vent damper failed to prove open within 45 seconds —
- If **POWER** light is steady: Usually indicates vent damper closed during run cycle —



Electrical shock hazard — Wherever you see **▲ TURN OFF POWER ▲**, follow the instructions. Failure to follow instructions could result in severe personal injury, death or substantial property damage.

- Reset boiler control by turning off power at service switch or turning down thermostat for 2 to 20 seconds.
- Thermostat should call for heat and appropriate zone valves open. The **TSTAT CIRC** and **LIMIT** lights should come on.

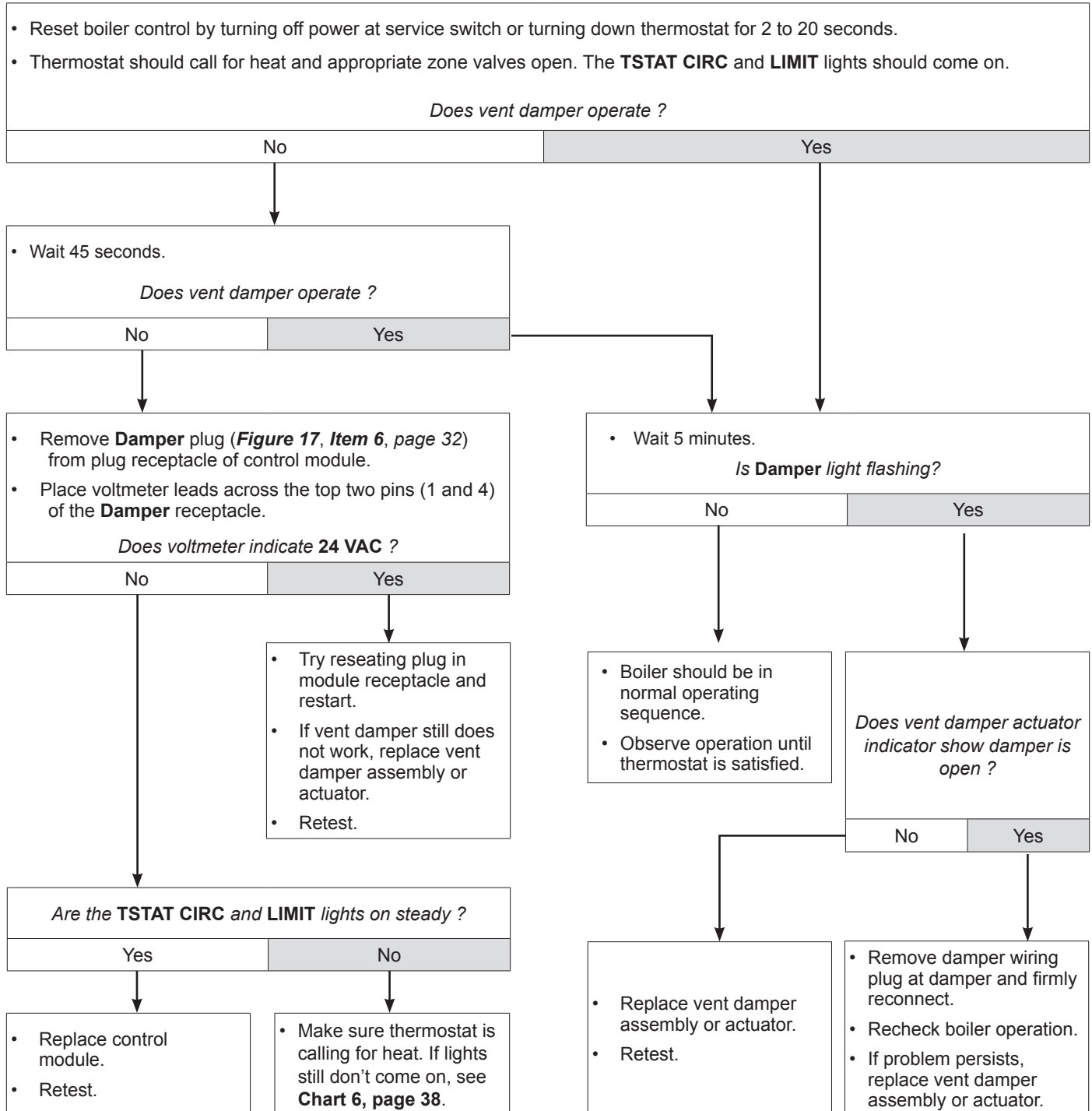

12 Troubleshooting – spark-ignited pilot boilers

CHART 4 — Spark-ignited pilot — FLAME & POWER lights flashing

— Usually indicates flame sensed when it shouldn't be there —



Electrical shock hazard — Wherever you see **▲ TURN OFF POWER ▲**, follow the instructions. Failure to follow instructions could result in severe personal injury, death or substantial property damage.

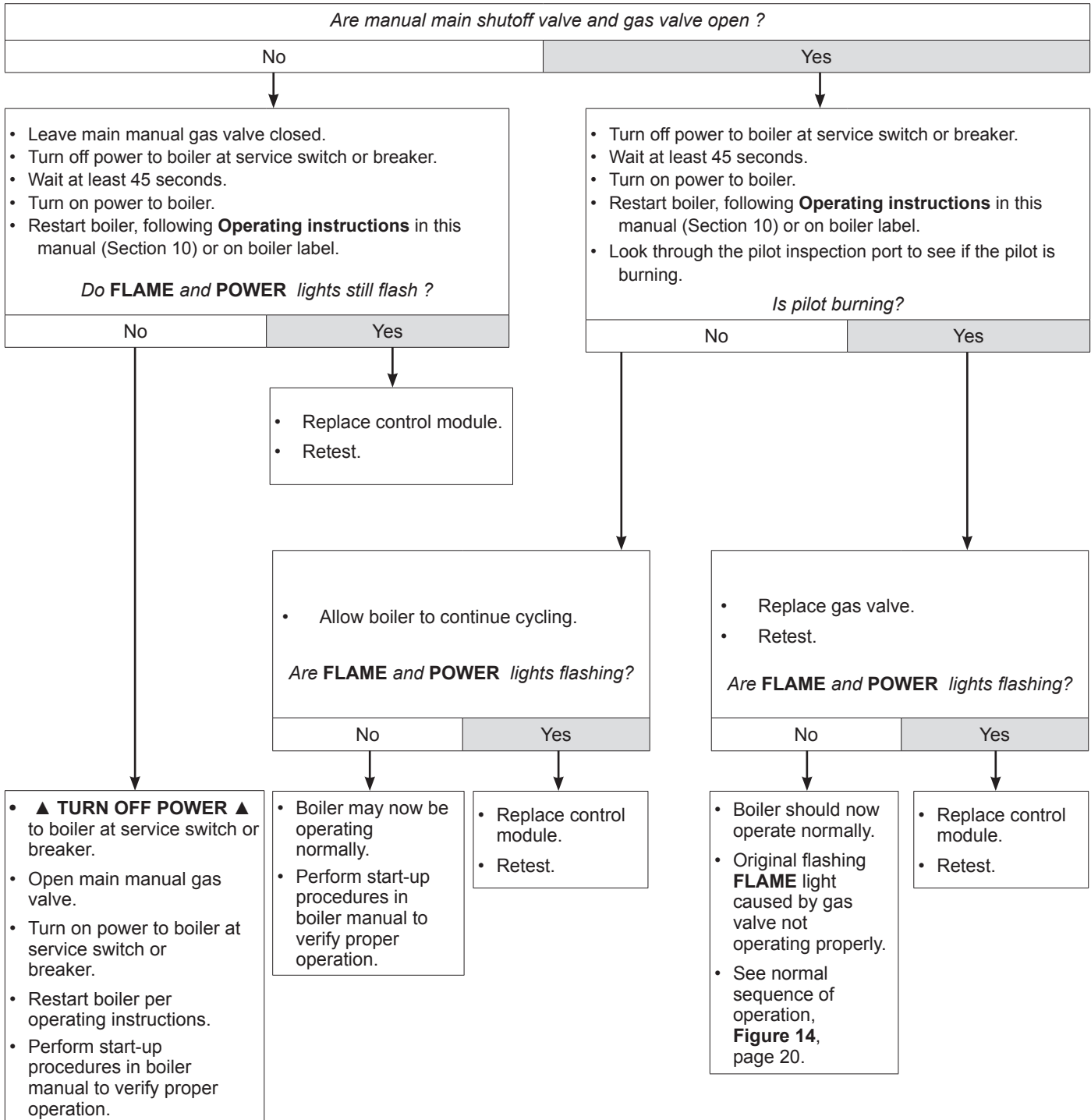

12 Troubleshooting – spark-ignited pilot boilers

CHART 5 — Spark-ignited pilot — FLAME light flashing and POWER light on steady
ALSO — Troubleshooting failure to establish main flame

▲WARNING Electrical shock hazard — Wherever you see **▲ TURN OFF POWER ▲**, follow the instructions. Failure to follow instructions could result in severe personal injury, death or substantial property damage.

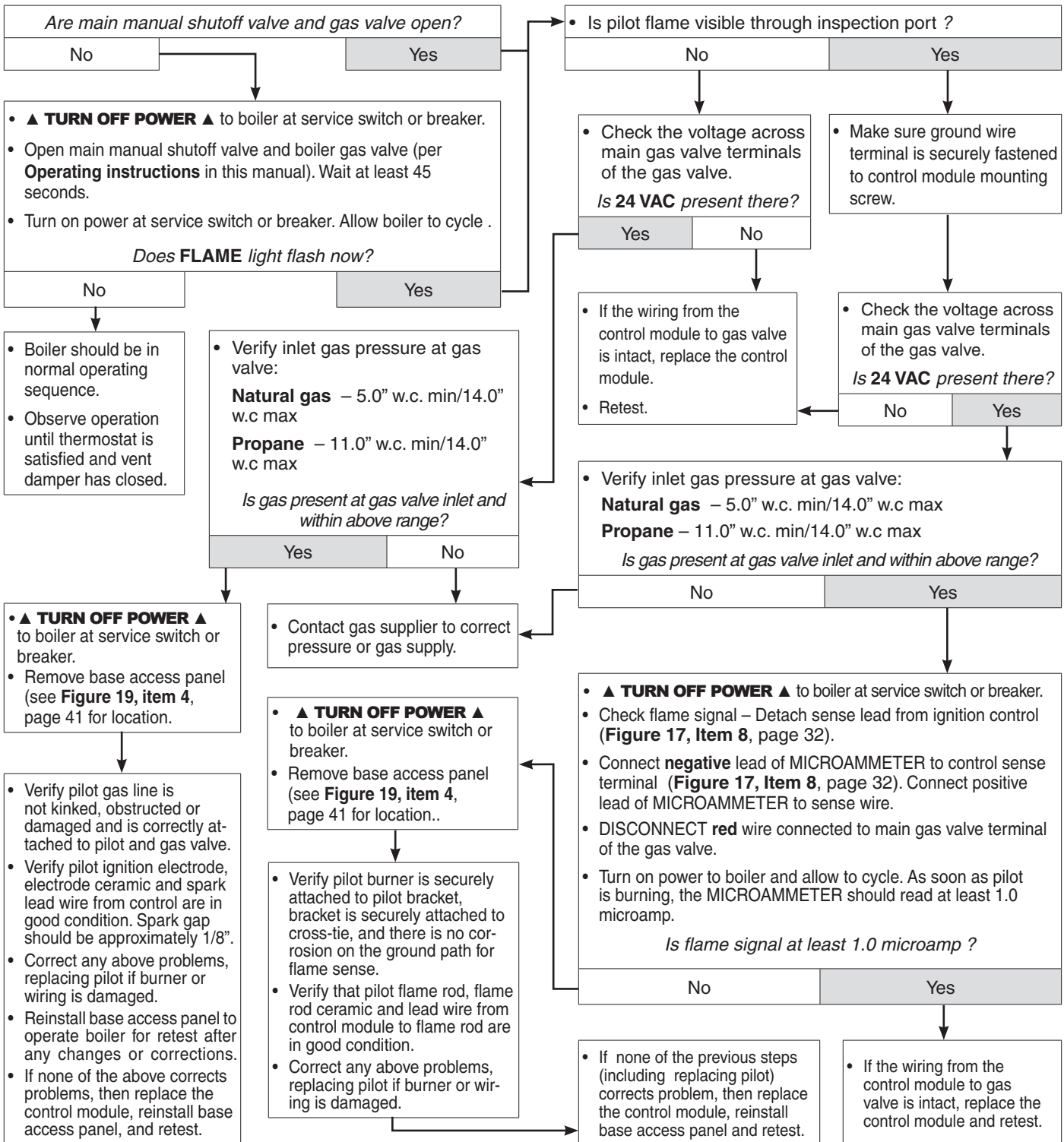

12 Troubleshooting – spark-ignited pilot boilers

CHART 6 — Spark-ignited pilot — Insufficient heat or no heat (POWER light on steady)



Electrical shock hazard — Wherever you see **▲ TURN OFF POWER ▲**, follow the instructions. Failure to follow instructions could result in severe personal injury, death or substantial property damage.

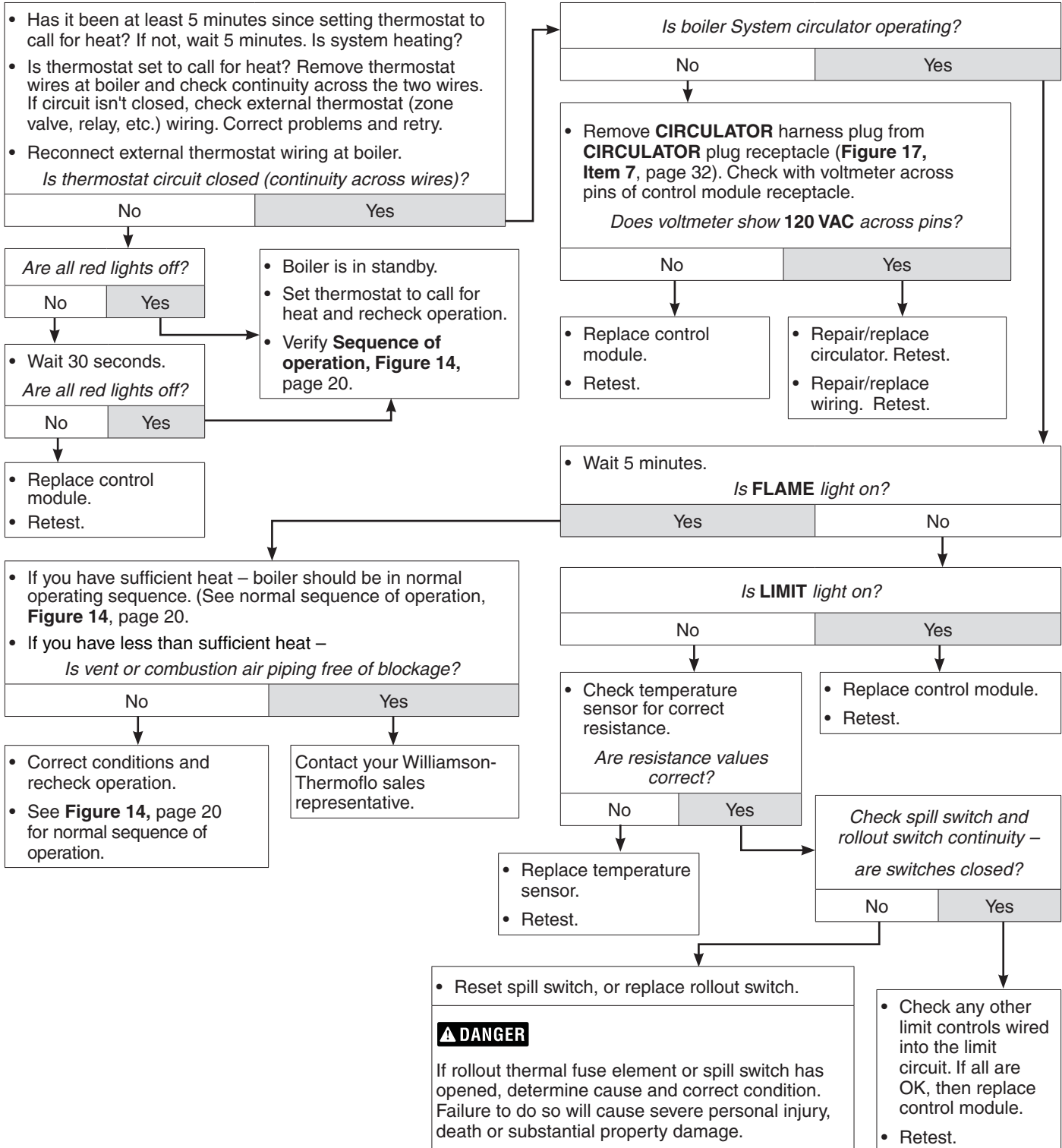

Handling ceramic fiber and fiberglass materials

REMOVAL OF COMBUSTION CHAMBER LINING OR BASE PANELS

⚠ WARNING

The combustion chamber lining or base insulation panels in this product contain ceramic fiber materials. Ceramic fibers can be converted to cristobalite in very high temperature applications. The International Agency for Research on Cancer (IARC) has concluded, “Crystalline silica inhaled in the form of quartz or cristobalite from occupational sources is carcinogenic to humans (Group 1):”

- Avoid breathing dust and contact with skin and eyes.
 - Use NIOSH certified dust respirator (N95). This type of respirator is based on the OSHA requirements for cristobalite at the time this document was written. Other types of respirators may be needed depending on the job site conditions. Current NIOSH recommendations can be found on the NIOSH web site at <http://www.cdc.gov/niosh/homepage.html>. NIOSH approved respirators, manufacturers, and phone numbers are also listed on this web site.
 - Wear long-sleeved, loose fitting clothing, gloves, and eye protection.
- Apply enough water to the combustion chamber lining or base insulation to prevent airborne dust.
- Remove combustion chamber lining or base insulation from the boiler and place it in a plastic bag for disposal.
- Wash potentially contaminated clothes separately from other clothing. Rinse clothes washer thoroughly.

NIOSH stated First Aid.

- Eye: Irrigate immediately
- Breathing: Fresh air.

REMOVAL OF FIBERGLASS WOOL — OR —

INSTALLATION OF FIBERGLASS WOOL, COMBUSTION CHAMBER LINING OR BASE PANELS:

⚠ WARNING

This product contains fiberglass jacket insulation and ceramic fiber materials in combustion chamber lining or base panels in gas fired products. Airborne fibers from these materials have been listed by the State of California as a possible cause of cancer through inhalation.

- Avoid breathing dust and contact with skin and eyes.
 - Use NIOSH certified dust respirator (N95). This type of respirator is based on the OSHA requirements for fiberglass wool at the time this document was written. Other types of respirators may be needed depending on the job site conditions. Current NIOSH recommendations can be found on the NIOSH web site at <http://www.cdc.gov/niosh/homepage.html>. NIOSH approved respirators, manufacturers, and phone numbers are also listed on this web site.
 - Wear long-sleeved, loose fitting clothing, gloves, and eye protection.
- Operations such as sawing, blowing, tear out, and spraying may generate airborne fiber concentration requiring additional protection.
- Wash potentially contaminated clothes separately from other clothing. Rinse clothes washer thoroughly.

NIOSH stated First Aid.

- Eye: Irrigate immediately
- Breathing: Fresh air.

13 Replacement parts

Figure 18 Section assembly, flue collector, draft hood and vent damper

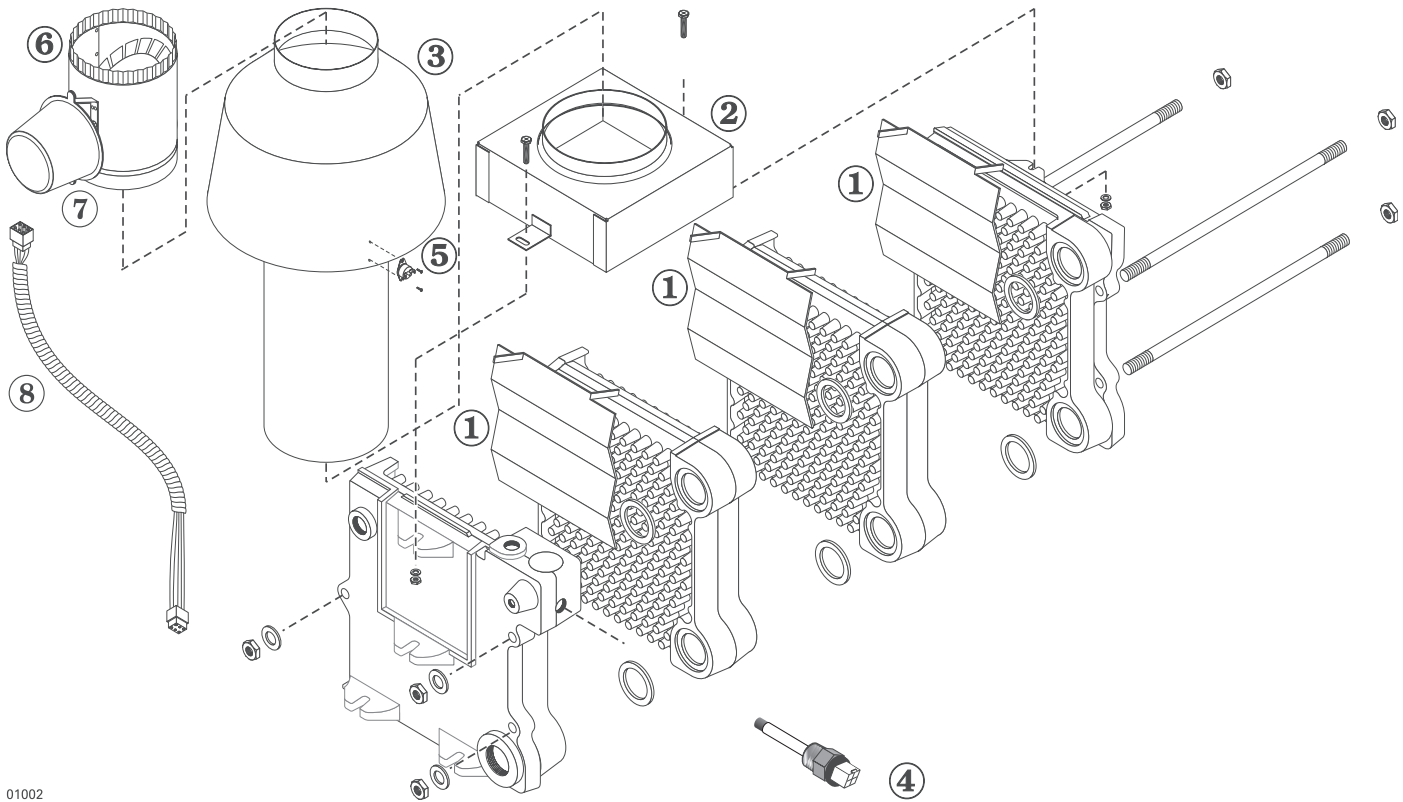

01002

Item number	Description	Part number
not shown	Replacement section assembly	GWA-052 321-114-345WT GWA-070 321-114-345WT GWA-105 321-114-346WT GWA-140 321-114-347WT GWA-175 321-114-348WT GWA-210 321-114-349WT GWA-245 321-114-350WT
1	Radiation plate (1 per joint)	460-003-700WT
2	Collector hood	GWA-052 381-354-625WT GWA-070 381-354-626WT GWA-105 381-354-627WT GWA-140 381-354-628WT GWA-175 381-354-629WT GWA-210 381-354-630WT GWA-245 381-354-631WT
3	Draffhood	GWA-052 450-021-240WT GWA-070 450-021-241WT GWA-105 450-021-242WT GWA-140 450-021-243WT GWA-175 450-021-244WT GWA-210 450-021-245WT GWA-245 450-021-246WT

Item number	Description	Part number
4	Temperature sensor	Tasseron TSL055D 381-356-577WT
5	Spill switch	510-300-014WT
6	Vent damper	4" GWA-052 Effikal RVGP-KS-4BKF 381-800-474WT GWA-070 * Johnson Controls Q35GB-2 Field Controls GVD-4
		5" GWA-105 Effikal RVGP-KS-5BKF 381-800-475WT * Johnson Controls Q35GD-2 Field Controls GVD-5
		6" GWA-140 Effikal RVGP-KS-6BKF 381-800-476WT GWA-175 * Johnson Controls Q35GF-2 Field Controls GVD-6
		7" GWA-210 Effikal RVGP-KS-7BKF 381-800-477WT GWA-245 * Johnson Controls Q35GH-2 Field Controls GVD-7
		* Johnson Controls damper assemblies consists of M35BC actuator and Y15 vent pipe
7	Vent damper actuator	Effikal RVGP 510-512-337WT
8	Vent damper harness	591-391-795WT

13 Replacement parts continued

Figure 19 Base assembly, manifold, orifices and burners

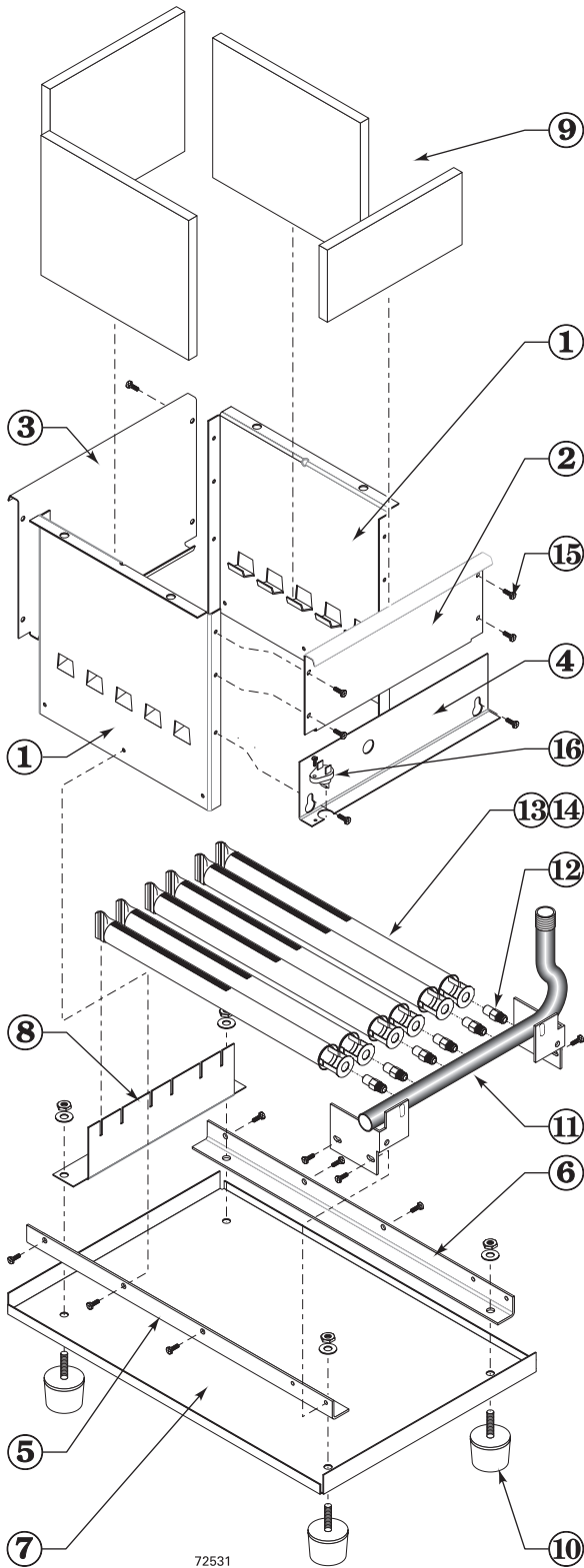

Item number	Description	Part number
	Base assembly kit	GWA-052 GWA-070 GWA-105 GWA-140 GWA-175 GWA-210 GWA-245 381-354-355WT 381-354-356WT 381-354-357WT 381-354-358WT 381-354-359WT 381-354-360WT 381-354-361WT
1	Base side panel (in Base assembly)	
2	Base front cross-tie assembly (in Base assembly)	
3	Base back cross-tie assembly (in Base assembly)	
4	Base access panel (in Base assembly)	
5	Base pan angle, left side (in Base assembly)	
6	Base pan angle, right side (in Base assembly)	
7	Base pan (in Base assembly)	
8	Burner rest	
9	Base insulation kit (included insulation for all base parts above plus gasket material needed between block assembly and base)	GWA-052 to GWA-140 GWA-175 to GWA-245 381-354-518WT 381-354-519WT
10	Boiler leg kit	
11	Manifold	GWA-052 GWA-070 GWA-105 GWA-140 GWA-175 GWA-210 GWA-245 591-126-615WT 591-126-616WT 591-126-617WT 591-126-618WT 591-126-619WT 591-126-556WT 591-126-557WT
12	Main burner orifice, sea level – Natural gas Main burner orifice, sea level – Propane gas	560-528-997WT 560-528-998WT
13	Burner, stainless steel	
14	Burner with pilot bracket (not shown)	
15	Screw, 10-32 x 3/8 STP Type D Hex, washer head slot ZP	
16	Rollout thermal fuse element	

13 Replacement parts continued

Figure 20 Jacket assembly

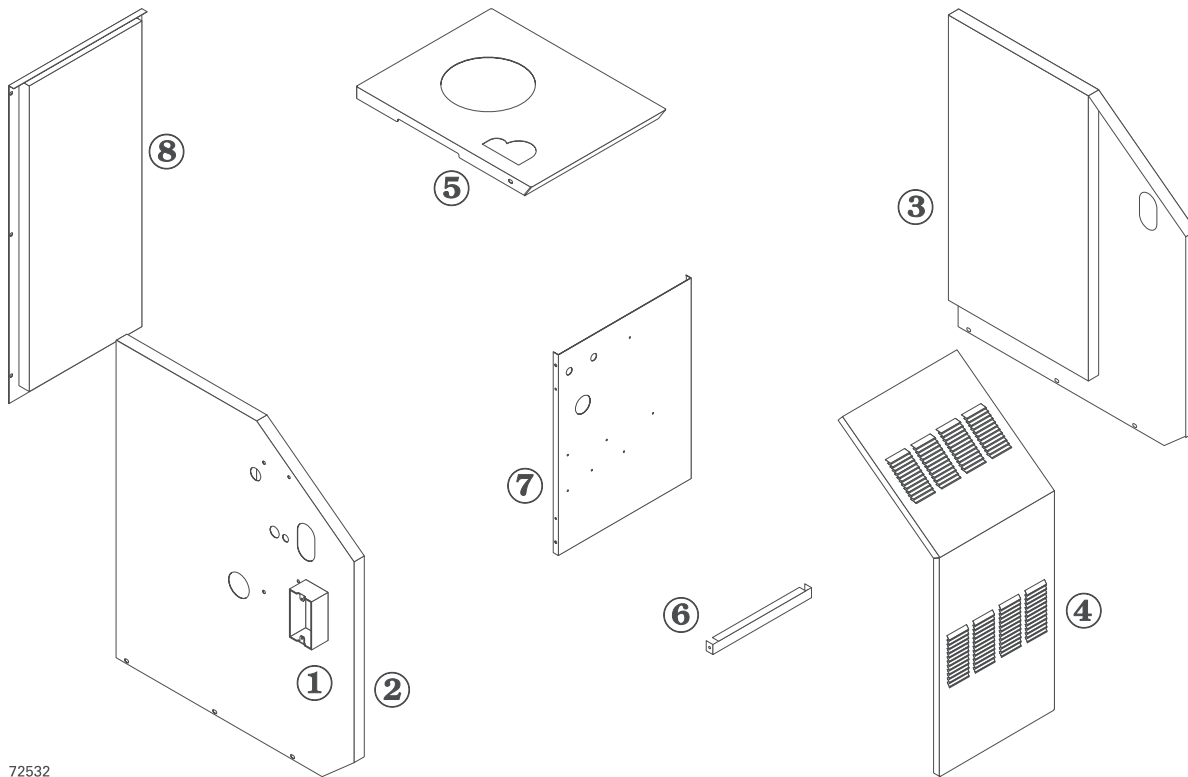

72532

Item number	Description	Part number	Part number	Item number	Description	Part number
1	Junction box, 2 x 4 (Available at local supply house)			5	Jacket panel, top	GWA-052 & GWA-070 GWA-105 GWA-140 GWA-175 GWA-210 GWA-245 431-223-433WT 431-223-434WT 431-223-435WT 431-223-436WT 431-223-437WT 431-223-438WT
2	Jacket panel, left side with insulation	GWA-052 GWA-070 GWA-105 GWA-140 GWA-175 GWA-210 GWA-245	<u>Natural Gas</u> 431-223-571WT 431-223-573WT 431-223-575WT 431-223-577WT 431-223-579WT 431-223-581WT 431-223-583WT <u>Propane Gas</u> 431-223-585WT 431-223-586WT 431-223-587WT 431-223-588WT 431-223-589WT 431-223-590WT 431-223-591WT	6	Jacket cross-tie	GWA-052 & GWA-070 GWA-105 GWA-140 GWA-175 GWA-210 GWA-245 431-223-507WT 431-223-508WT 431-223-509WT 431-223-510WT 431-223-511WT 431-223-512WT
3	Jacket panel, right side with insulation	GWA-052 GWA-070 GWA-105 GWA-140 GWA-175 GWA-210 GWA-245	431-223-572WT 431-223-574WT 431-223-576WT 431-223-578WT 431-223-580WT 431-223-582WT 431-223-584WT	7	Jacket panel, interior, with insulation	GWA-052 & GWA-070 GWA-105 GWA-140 GWA-175 GWA-210 GWA-245 431-223-427WT 431-223-428WT 431-223-429WT 431-223-430WT 431-223-431WT 431-223-432WT
4	Jacket panel, door	GWA-052 & 070 GWA-105 GWA-140 GWA-175 GWA-210 GWA-245	431-223-592WT 431-223-593WT 431-223-594WT 431-223-595WT 431-223-596WT 431-223-597WT	8	Jacket panel, rear, with insulation	GWA-052 & GWA-070 GWA-105 GWA-140 GWA-175 GWA-210 GWA-245 431-223-444WT 431-223-445WT 431-223-446WT 431-223-447WT 431-223-448WT 431-223-449WT

WARNING The boiler contains ceramic fiber and fiberglass materials. Use care when handling these materials per instructions on page 39 of this manual. Failure to comply could result in severe personal injury.

13 Replacement parts continued

Figure 21 Trim assembly

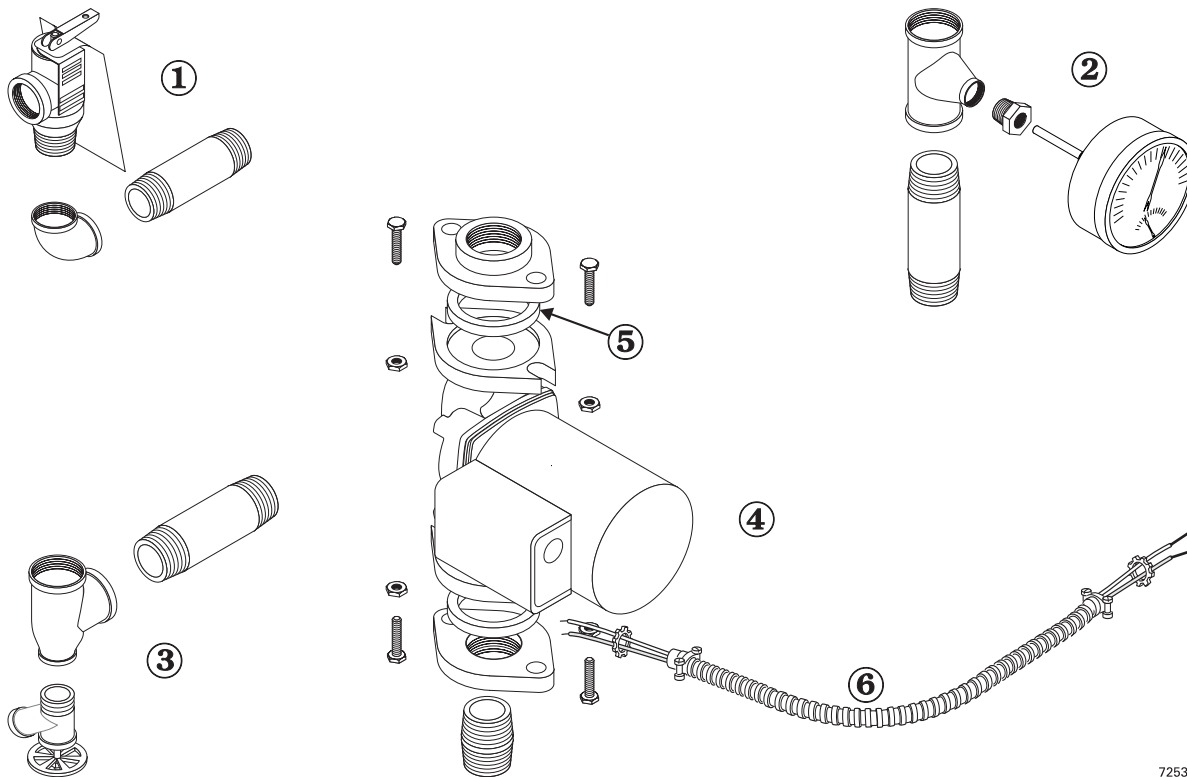

72533

Item number	Description	Manufacturer	Manufacturer's Part number	Part number
1	Pressure relief valve, ASME, 30 PSIG, 3/4" male inlet	Watts	M330	511-546-920WT
	Pressure relief valve, ASME, 30 PSIG, 3/4" female inlet <i>(Fittings shown are factory-installed on boiler.)</i>	Watts	335	511-546-924WT
2	Combination pressure-temperature gauge, with 2 1/2" short shank	Amekai	OS234JDTW003	510-218-099WT
3	Drain valve, 3/4" NPT, 1-1/2" Shank <i>(Fittings shown are included with boiler.)</i>			511-210-423WT
4	Circulator <i>(Fittings shown are shipped loose with boiler.)</i>	Taco	007	511-405-113WT
5	Circulator gasket, universal (2 per boiler)			590-317-535WT
not shown	Circulator hardware kit, includes: 2 flanges, 4 nuts, 4 bolts, 2 pipe nipples — 1" NPT — GWA-052 through GWA-140 1 1/2" NPT — GWA-175 through GWA-245			381-354-525WT 381-354-526WT
6	Circulator wiring harness			591-391-976WT

13 Replacement parts continued

Figure 22 Gas control assembly **Spark-ignited pilot controls**

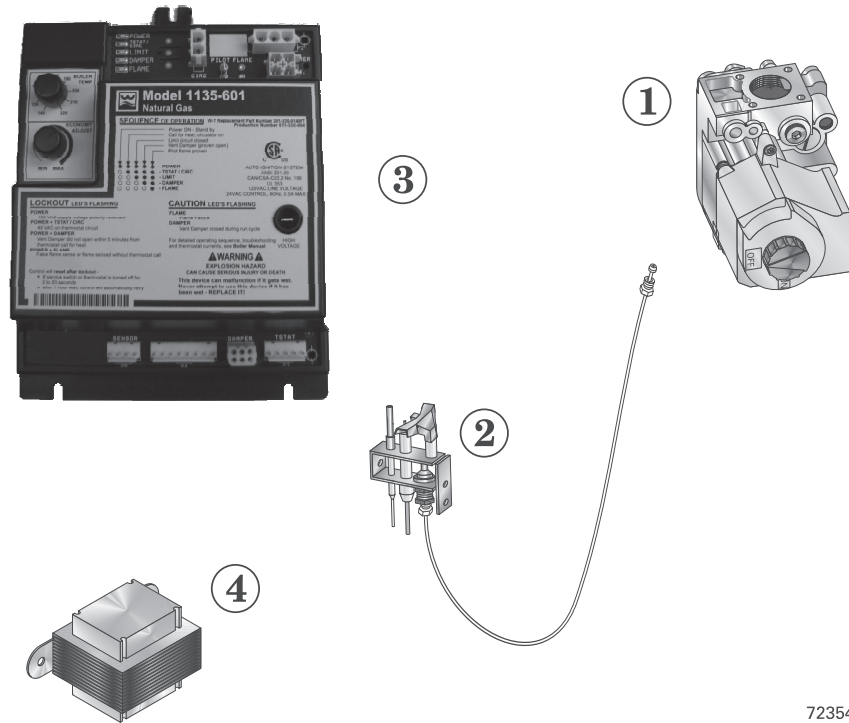

72354

Item number	Description	Boiler model	Manufacturer	Manufacturer's part number	Part number
Natural gas components					
1	Gas valve, 1/2" x 1/2"	GWA-052 through GWA-175	Honeywell	VR8204A2001	511-044-381WT
	Gas valve, 3/4" x 3/4"	GWA-210 through GWA-245	White-Rodgers Robertshaw Honeywell White-Rodgers	36E-266 7200IPER VR8304M4348 36C74-474	511-044-382WT
2	Pilot kit w/orifice & aluminum pilot gas tubing		Williamson-Thermoflo		511-330-218WT
Liquefied Petroleum (Propane) gas components					
1	Gas valve, 3/4" x 3/4"	GWA-052 through GWA-210	Honeywell	VR8304P4330	511-044-356WT
	Gas valve, 3/4" x 3/4"	GWA-245		VR8304K4822 VR8304K4913	511-044-366WT
2	Pilot kit w/orifice & aluminum pilot gas tubing		Williamson-Thermoflo		511-330-273WT
Natural gas and Liquefied Petroleum (Propane) gas components					
3	Control module - Natural gas		United Technologies	1135-601	381-330-014WT
	- Liquefied Petroleum (Propane) gas			1135-602	381-330-016WT
not shown	Wiring harness, junction box to control module		Williamson-Thermoflo		591-391-975WT
not shown	Wiring harness, controls to control module		Williamson-Thermoflo		591-391-977WT
not shown	Wiring harness, thermostat		Williamson-Thermoflo		591-391-994WT
not shown	Wiring harness, sensor (Natural gas)		Williamson-Thermoflo		591-391-995WT
not shown	Wiring harness, sensor (Propane gas)		Williamson-Thermoflo		591-391-000WT
4	Control transformer		Honeywell		381-356-578WT

14 Dimensions

Figure 23 Dimensional drawing — ALL DIMENSIONS IN INCHES

- ① Supply piping (Note 1)
- ② Return piping (Note 1)
- ③ Relief valve, 3/4" NPT
- ④ 1/2" NPT to expansion tank/air vent
- ⑤ Vent connection to vent damper
- ⑥ Draft hood
- ⑦ Gas supply piping
- ⑧ Drain valve
- ⑨ Gas supply entrance (right or left side)
- ⑩ Pressure/temperature gauge

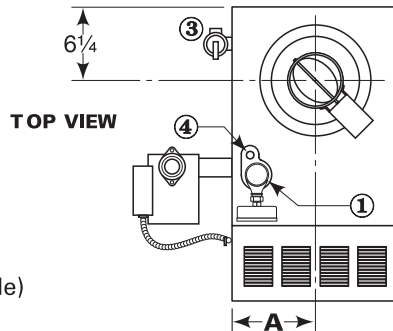

⚠ DANGER

Do not cut or alter draft hood in any way. Boiler combustion will be affected, causing severe personal injury, death or substantial property damage.

Note 1: Boiler supply and return tappings are both 1 1/4" NPT. See Table 4, page 10 for recommended system supply and return piping sizes.

Note 2: Boiler circulator is shipped loose. Circulator may be mounted on either boiler supply or return piping. Circulator flange provided with boiler is same size as recommended pipe size in Table 4, page 10.

ALL DIMENSIONS IN INCHES

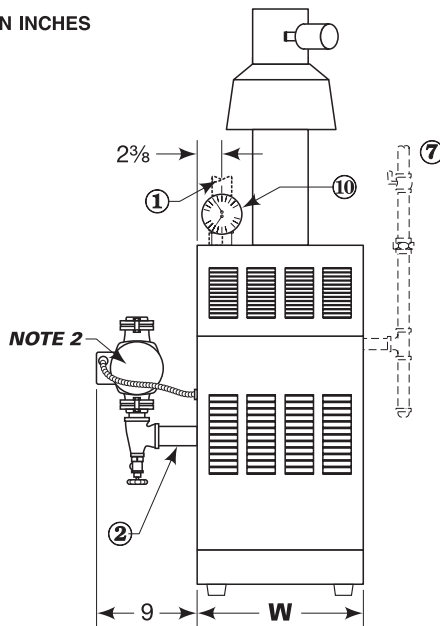
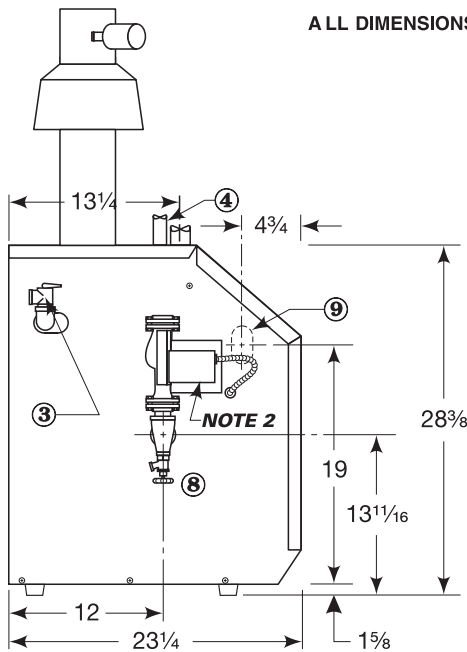

NOTE 2

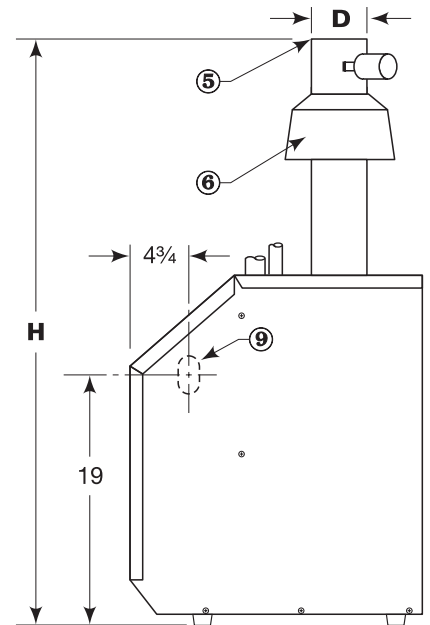

72535

LEFT SIDE

FRONT

RIGHT SIDE

Boiler model number	Supply tappings (inches NPT)	Return tappings (inches NPT)	Gas connection & manifold size (Note 3) (inches NPT)	"A" Vent location (inches)	"D" Vent diameter (inches)	"W" Jacket width (inches)	"H" Damper height (inches)
GWA-052	1 1/4	1 1/4	1/2	5	4	10	45 3/8
GWA-070	1 1/4	1 1/4	1/2	5	4	10	52 3/8
GWA-105	1 1/4	1 1/4	1/2	6 1/2	5	13	54 3/8
GWA-140	1 1/4	1 1/4	1/2	8	6	16	57 3/8
GWA-175	1 1/4	1 1/4	1/2	9 1/2	6	19	60 3/8
GWA-210	1 1/4	1 1/4	1/2	11	7	22	62 3/8
GWA-245	1 1/4	1 1/4	1/2	12 1/2	7	25	64 3/8

Note 3: Size gas piping from meter to boiler per local utility requirements.

15 Ratings

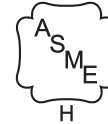

Boiler model number	0-2,000 feet altitude		2,000-4,500 feet altitude		Net AHRI ratings (Btuh)	Boiler water content (gallons)	DOE Seasonal efficiency (% A.F.U.E.)	Chimney and breeching size
	Input (Btuh)	DOE Heating Capacity (Output)(Btuh)	Input (Btuh)	Output (Btuh)			N - L	
(Note 3)		(Note 1)	(Note 4)		(Note 2)		(Note 3)	
GWA-052	52,000	43,000	46,800	37,400	37,000	1.5	83.0	4”I.D.x20”
GWA-070	70,000	58,000	63,000	50,400	50,000	1.5	83.0 Note 5	4”I.D.x20”
GWA-105	105,000	88,000	94,500	75,600	77,000	2.1	83.0	5”I.D.x20”
GWA-140	140,000	117,000	126,000	100,800	102,000	2.7	82.5	6”I.D.x20”
GWA-175	175,000	145,000	157,500	126,000	126,000	3.3	82.2	6”I.D.x20”
GWA-210	210,000	175,000	189,000	151,200	151,000	3.8	82.4	7”I.D.x20”
GWA-245	245,000	202,000	220,500	176,400	176,000	4.4	82.2	7”I.D.x20”

1. Based on standard test procedures prescribed by the United States Department of Energy.
2. Net AHRI ratings are based on net installed radiation of sufficient quantity for the requirements of the building and nothing need be added for normal piping and pickup. Ratings are based on a piping and pickup allowance of 1.15. An additional allowance should be made for unusual piping and pickup loads.
3. See information at right for model number suffixes. Letters shown are model number suffixes. An “N” after the model number designates natural gas. An “L” designates propane gas. The letter after the “-” designates the pilot ignition system — “I” for spark-ignited pilot. For example, a suffix “L-I” means a propane spark-ignited pilot boiler.
4. Contact your local dealer regarding information and parts for high altitude applications.
5. The **DOE** heating capacity output for this unit is 59,000 Btuh & Net AHRI rating is 50,000 Btuh.

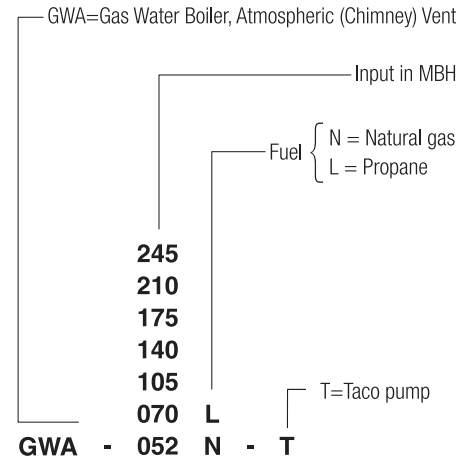

NOTICE Install GWA boilers for residential radiant panel systems, converted gravity heating systems or other low water temperature applications per instructions in this manual to avoid damage due to condensation.

GWA boilers are CSA design certified for installation on combustible flooring.

GWA boilers are ASME rated for 50 psig working pressure.

16 Notes

W-T
8201 W. Calumet Rd.
Milwaukee, WI 53223