

# OSB

## Oil-Fired Steam Boilers

# Boiler Manual

Contents	Page
1 Prepare boiler location .....	2
2 Prepare boiler .....	5
3 Connect breeching .....	6
4 Connect steam piping .....	7
5 Connect tankless heater piping, if used .....	10
6 Connect wiring .....	11
7 Connect oil piping .....	14
8 Start-up .....	15
9 Checkout procedure .....	16
10 Service and maintenance .....	18
11 Replacement parts .....	22
12 Dimensions .....	26
13 Ratings .....	27

### Hazard definitions

**DANGER** Hazards that **will cause severe** personal injury, death or substantial property damage.

**WARNING** Hazards that **can cause severe** personal injury, death or substantial property damage.

**CAUTION** Hazards that **will or can cause minor** personal injury or property damage.

**NOTICE** Special instructions on installation, operation or maintenance that are important but not related to personal injury or property damage.

**WARNING** **INSTALLER** — Read all instructions before installing. **Read page 2 first.** Follow all instructions in proper order to prevent personal injury or death.

- Consider piping and installation when determining boiler location.
- Any claims for damage or shortage in shipment must be filed immediately against the transportation company by the consignee.

**WARNING** **USER** — Please read the following. Failure to comply could result in severe personal injury, death or substantial property damage.

- **This manual is for use only by your qualified heating installer/service technician.**
- Please see the User's Information Manual for your reference.
- Have the boiler serviced by a qualified service technician, at least annually.

**WARNING** This manual must only be used by a **qualified heating installer/service technician**. Boiler and burner must be installed and serviced only by a qualified heating installer/service technician. Failure to comply could result in severe personal injury, death or substantial property damage.

**NOTICE** When calling or writing about the boiler— Please have: • boiler model number from the boiler rating label and • CP number from the boiler jacket. You may list the CP number in the space provided on the "Installation and service certificate" found on page 17.

## Read this first!

**WARNING** Failure to adhere to the guidelines below can result in severe personal injury, death or substantial property damage.

### When servicing boiler —

1. To avoid electric shock, disconnect electrical supply before performing maintenance.
2. To avoid severe burns, allow boiler to cool before performing maintenance.

### Boiler operation —

3. Do not block flow of combustion or ventilation air to boiler.
4. Should overheating occur, turn off or disconnect electrical supply to boiler **and** shut off the oil supply at a location external to the appliance, if possible.
5. Do not use this boiler if any part has been under water. Immediately call a qualified service technician to inspect the boiler and to replace any part of the control system and any burner control that has been under water.

### Boiler water —

6. DO NOT use petroleum-based cleaning or sealing compounds in boiler system. Water seal deterioration will occur, causing leakage between boiler sections, circulator flanges, diaphragm tanks or other system components. This can result in substantial property damage.
7. DO NOT use "homemade cures" or "boiler patent medicines". Serious damage to boiler, personnel and/or property may result.
8. Continual fresh makeup water will reduce boiler life. Mineral buildup in sections reduces heat transfer, overheats cast iron, and causes section failure. Addition of oxygen and other gases can cause internal corrosion. Leaks in boiler or piping must be repaired at once to prevent makeup water.
9. Do not add cold water to hot boiler. Thermal shock can cause sections to crack.

## 1 Prepare boiler location

### Codes & checklist

#### Installations must follow these codes:

- Local, state, provincial, and national codes, laws, regulations and ordinances.
- NFPA-31, Installation of Oil-Burning Equipment.
- Standard for Controls and Safety Devices for Automatically Fired Boilers, ANSI/ASME CSD-1, when required.
- National Electrical Code.

### Certification

**NOTICE** The OSB boiler burner and controls met safe lighting and other performance criteria when boiler underwent tests specified in CSA B140.0 and B140.7.1.

### Before locating the boiler:

- Check for nearby connection to:
    - Makeup water and steam piping
    - Venting connections (page 6)
    - Combustion and ventilation air provisions (page 4)
    - Oil supply piping (page 14 and burner manual)
    - Electrical power
  - Check area around boiler. Remove any combustible materials, gasoline and other flammable liquids.
- WARNING** Failure to keep boiler area clear and free of combustible materials, gasoline and other flammable liquids and vapors can result in severe personal injury, death or substantial property damage.
- Boiler must be installed so that burner and control system components are protected from dripping or spraying water or rain during operation or service.
  - If new boiler will replace existing boiler, check for and correct system problems, such as system leaks causing oxygen corrosion or section cracks from hard water deposits.

# 1 Prepare boiler location continued

## Clearances

### Minimum clearance to combustible materials

- Minimum clearances from vent pipe to combustible material (see Figure 1, vent clearances indicated with “\*”) :
  - Type “L” doublewall vent — 6 inches minimum
  - Singlewall vent — 18 inches minimum

**NOTICE** Flue pipe clearances must take precedence over jacket clearances (listed below).

### Service clearances

- Recommended **service** clearances (see Figure 1):
  - Front and top — 24 inches
  - Left side, back and right side — 6 inches
  - Right side for burner door swing radius — 12 inches.

**Figure 1** Minimum clearances

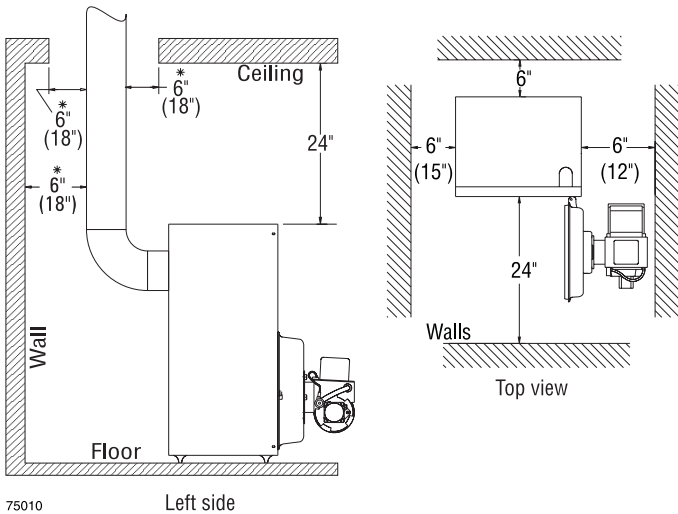

## Flooring and foundation

### Flooring

The OSB boiler is approved for installation on combustible flooring, but must never be installed on carpeting.

**WARNING** Do not install boiler on carpeting even if foundation is used. Fire can result, causing severe personal injury, death or substantial property damage.

### Foundation

- Provide a solid brick or minimum 2-inch thick concrete foundation pad if any of the following is true:
  - floor can become flooded.
  - the boiler mounting area is not level.
- See Table 1 for minimum foundation dimensions.

**Table 1** Minimum foundation size

Boiler model number	Length inches	Width inches	Minimum height inches
OSB-3	17	22	2
OSB-4	20	22	2
OSB-5	23	22	2
OSB-6	26	22	2

## Residential garage installations

Take the following special precautions when installing the boiler in a residential garage. If the boiler is located in a residential garage:

- Mount the boiler a minimum of 18 inches above the floor of the garage to ensure the burner and ignition devices will be no less than 18 inches above the floor.
- Locate or protect the boiler so it cannot be damaged by a moving vehicle.

75010

Left side

# 1 Prepare boiler location continued

## Air for combustion and ventilation

- WARNING** Adequate combustion and ventilation air:
- Assures proper combustion.
  - Reduces risk of severe personal injury or death from possible flue gas leakage and carbon monoxide emissions.
  - Do not install exhaust fan in boiler room.

### Consider building construction

Older buildings with single-pane windows, minimal weather-stripping and no vapor barrier often provide enough natural infiltration and ventilation without dedicated openings.

New construction or remodeled buildings are most often built tighter. Windows and doors are weather-stripped, vapor barriers are used and openings in walls are caulked. As a result, such tight construction is unlikely to allow proper natural air infiltration and ventilation.

Follow state, provincial or local codes when sizing adequate combustion and ventilation air openings. In absence of codes, use the following guidelines when boiler is in a confined room (defined by NFPA 31 as less than 7200 cubic feet per 1 GPH input of all appliances in area. A room 8 ft. high x 33.5 ft. x 33.5 ft. is 7200 cu. ft.).

### Provide two permanent openings:

One within 12 inches of ceiling, one within 12 inches of floor. Minimum height or length dimension of each rectangular opening should be at least 3 inches.

### When inside air is used:

Each opening must freely connect with areas having adequate infiltration from outside. Each opening should be at least 140 sq. in. per 1 GPH input (1 sq. in. per 1000 Btu input) of all fuel-burning appliances plus requirements for any equipment that can pull air from room (including clothes dryer and fireplace).

### When outside air is used:

Connect each opening directly or by ducts to the outdoors or to crawl or attic space that freely connects with outdoors. Size per below:

- Through outside wall or vertical ducts — at least 35 sq. in. per 1 GPH input (1 sq. in. per 4000 Btu input) of all fuel burning appliances plus requirements for any equipment that can pull air from room (including clothes dryer and fireplace).
  - Through horizontal ducts — at least 70 sq. in. per 1 GPH boiler input (1 sq. in. per 2000 Btu input) of all fuel-burning appliances plus requirements for any equipment that can pull air from room (including clothes dryer and fireplace).
  - Where ducts are used, they should have same cross-sectional area as free area of openings to which they connect. Compensate for louver, grille or screen blockage when calculating free air openings. Refer to their manufacturer’s instructions for details. If unknown, use:
    - Wood louvers, which provide 20-25% free air.
    - Metal louvers or grilles, which provide 60-75% free air.
- Lock louvers in open position or interlock with equipment to prove open before boiler operation.

## Air contamination

Please review the following information on potential combustion air contamination problems.

See Table 2 for products and areas which may cause contaminated combustion air.

- WARNING** To prevent potential of severe personal injury or death, check for products or areas listed below before installing boiler. If any of these contaminants are found:
- remove contaminants permanently.
- OR —
- isolate boiler and provide outside combustion air. See national, provincial or local codes for further information.

**Table 2** Corrosive contaminants and likely locations

Products to avoid
Spray cans containing chloro/fluorocarbons
Permanent wave solutions
Chlorinated waxes/cleaners
Chlorine-based swimming pool chemicals
Calcium chloride used for thawing
Sodium chloride used for water softening
Refrigerant leaks
Paint or varnish removers
Hydrochloric acid/muriatic acid
Cements and glues
Antistatic fabric softeners used in clothes dryers
Chlorine-type bleaches, detergents, and cleaning solvents found in household laundry rooms
Adhesives used to fasten building products and other similar products
Areas likely to have contaminants
Dry cleaning/laundry areas and establishments
Swimming pools
Metal fabrication plants
Beauty shops
Refrigeration repair shops
Photo processing plants
Auto body shops
Plastic manufacturing plants
Furniture refinishing areas and establishments
New building construction
Remodeling areas
Garages with workshops

## 2 Prepare boiler

### Place boiler

**WARNING** The boiler contains ceramic fiber and fiberglass materials. Use care when handling these materials per instructions on page 28 of this manual. Failure to comply could result in severe personal injury.

1. Remove boiler from pallet.

**NOTICE** Do not drop boiler or bump jacket or burner on floor or pallet. Damage to boiler or burner can result.

**CAUTION** Smaller sized boilers may be top heavy. Use caution when handling to avoid minor personal injury or property damage.

2. Check level. Shim legs if needed.
3. Open burner mounting door. Verify that chamber ceramic liner is securely in place on target wall, chamber floor and burner door. Verify door seal is intact and in place. Close and securely bolt the door.
4. Visually check:
  - a. Flue collector hood seal.
  - b. Burner mounting door seal.

**WARNING** Obtain gas-tight seal to prevent possible flue gas leakage and carbon monoxide emissions, which can lead to severe personal injury or death.

### Tankless heater, if used

1. Remove tankless heater knockout in left side of jacket panel.
2. Remove tankless heater cover plate and gasket.
3. Install new gasket and tankless heater over studs around opening. Secure with 3/8" nuts.
4. Install tankless heater operating control in tapping in tankless heater. If not furnished, use operating control with maximum 10 °F differential.

### Hydrostatic pressure test

1. Remove steam pressure gauge furnished with boiler. Install water pressure gauge for test only. Be sure gauge can handle test pressure.
2. Install air vent in tapping on top of boiler.
3. Remove pressure control and low water cutoff. Plug tappings.
4. Plug supply and return tappings.
5. Drain valve is already factory-installed.
6. Fill boiler. Vent all air. Pressure test boiler at 45-55 psig.

**WARNING** Do not leave boiler unattended. Cold water fill can expand and damage cast iron, resulting in severe personal injury, death or substantial property damage.

7. Check for maintained gauge pressure for more than 10 minutes. Visually check for leaks if gauge pressure drops.
8. Drain boiler. Repair leaks if found.

**WARNING** Using petroleum-based compounds to repair leaks can damage system components, resulting in property damage.

9. Retest boiler after repairing leaks.
10. Remove pressure gauge, air vent and plugs. Reinstall steam pressure gauge, pressure control and low water cutoff furnished with boiler.

### 3 Connect breaching

#### General venting requirements

**WARNING** Failure to follow all instructions can result in flue gas spillage and carbon monoxide emissions, causing severe personal injury or death.

**DANGER** Inspect existing chimney before installing boiler. Insufficient draft can cause flue gas leakage and carbon monoxide emissions. Failure to clean or replace perforated pipe or tile lining and/or patch mortar and joints can cause severe personal injury or death.

- The OSB boilers are designed to operate with an over-fire draft of -0.01" to -0.02" w.c. Proper draft for these boilers may be achieved using either a conventional chimney (natural draft) or a power vent (sidewall) system that has been properly designed for use with oil-fired equipment. Power vent manufacturer's instructions must be followed.
- Use vent material approved by local codes for oil-fired burners. In their absence, refer to:
  - NFPA 31, Installation of Oil-Burning Equipment.
  - NFPA 211, Standard for Chimneys, Fireplaces, Vents and Solid Fuel Burning Appliances.
  - NFPA 211 requires chimney to be lined before connected to boiler.
- To prevent downdrafts, extend chimney at least 3 feet above highest point where it passes through roof and 2 feet higher than any portion of building within 10 feet. Increase chimney cross-sectional area and height at least 4% per 1,000 feet above sea level.
- Provide minimum clearances from vent (flue) pipe to combustible material:
  - Type "L" doublewall vent — 6 inches minimum
  - Singlewall vent — 18 inches minimum
- Minimum chimney sizes should be used. See Table 3.

**NOTICE** Oversized chimneys, outside masonry chimneys and/or derated inputs can result in condensation in chimney.

#### Connect breaching

**WARNING** Long horizontal breachings, excessive number of tees and elbows, or other obstructions restricting combustion gas flow can result in possibility of condensation, flue gas leakage and carbon monoxide emissions, which can lead to severe personal injury or death.

- See Figure 2.
- Connect full-sized breaching when possible. See Table 3.
- Connection must be made above bottom of chimney to avoid blockage. Breaching must not enter chimney far enough to cause obstruction. Use thimble or slip joint where breaching enters chimney to allow removal for cleaning.

Figure 2 Chimney and breaching connections

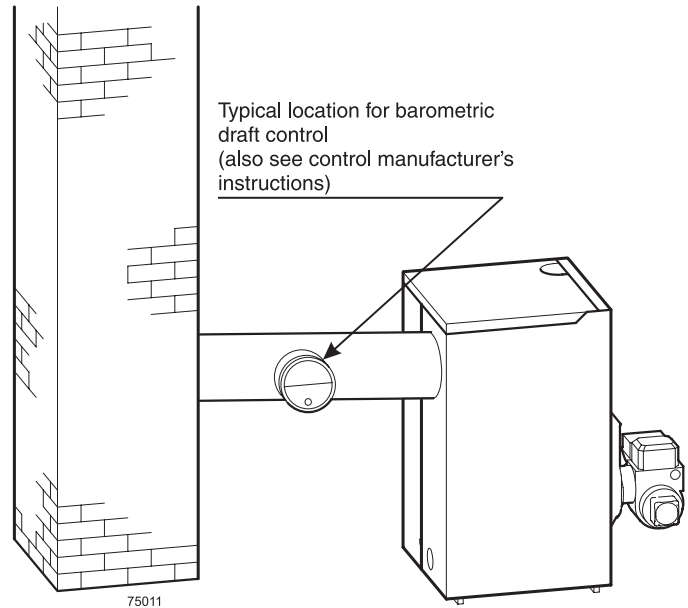

Table 3 Chimney and breaching minimum sizes

Boiler model number	Minimum breaching diameter Note 1	Minimum I=B=R chimney size		Minimum chimney height
		Rectangle Note 2	Round	
OSB-3	5"	8" x 8"	6"	15'
OSB-4	6"	8" x 8"	6"	15'
OSB-5	6"	8" x 8"	6"	15'
OSB-6	7"	8" x 8"	7"	15'

Notes:  
 1. Flue collar on boiler is 7" diameter  
 2. 6¾" x 6¾" inside liner

- When burner and boiler are properly installed, draft overfire will be approximately -0.01" to -0.02" W.C. Install barometric control in breaching, per control manufacturer's instructions, when excess draft needs to be relieved or to comply with applicable codes and regulations. Use draft gauge to adjust proper opening.
- An induced draft fan for the chimney may be necessary if:
  - Excessive resistance to flow of combustion gases can be expected.
  - Cross-sectional area of chimney is smaller than minimum recommended.
  - Chimney height is less than recommended.



## 4 Connect steam piping

### General

If installation is to comply with special codes, additional limit controls may be required. If installing a float-type low water cutoff, use only those devices that can be connected to the boiler gauge glass tapplings. Refer to the wiring diagrams on pages 12 and 13 for correct wiring location of additional limit controls.

### Relief valve

Install boiler relief valve in the 3/4" tapping in the back of the boiler, using the 3/4" nipple and elbow supplied in the bag with relief valve.

#### WARNING

Follow the steps below to avoid potential severe personal injury, death or substantial property damage.

- When installing the relief valve, ensure that all connections, including the valve inlet, are clean and free from any foreign matter.
- Mount the relief valve only in the vertical position, directly connected to the tapping designated in the manual on top of the boiler.
- Use pipe compound sparingly, or tape, on external threads only.
- Do not use a pipe wrench! Use proper type and size wrench on wrench pads only.

#### DANGER

During operation, this valve may discharge large amounts of steam and/or hot water. Therefore, to reduce the potential for bodily injury and property damage, a discharge line MUST be installed that:

- Is connected from the outlet to a safe point of discharge with no intervening valve.
- Allows complete drainage of both the valve and the discharge line.
- Is independently supported and securely anchored so as to avoid applied stress as possible.
- Terminates freely to atmosphere where any discharge will be clearly visible and is at no risk of freezing.
- Is, over its entire length, of a pipe size equal to or greater than that of the valve outlet.

Use only schedule 40 metal pipe for discharge. (Do not use schedule 80, extra strong or double strong pipe or connections.) DO NOT CAP, PLUG OR OTHERWISE OBSTRUCT DISCHARGE PIPE OUTLET! If discharge is piped upward, a condensate drain must be provided in the elbow below the vertical pipe to prevent condensate from returning into the valve. Failure to comply with these instructions will cause a dangerous spray of hot water and steam that would cause severe personal injury or death.

#### CAUTION

The piping in Figure 3 applies only to the special case of counterflow steam systems. Refer to page 8 for parallel flow steam systems. See below.

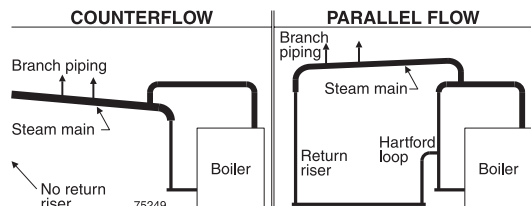

### Near-boiler piping

See Figures 4 and 5, page 8, for recommended piping of boiler sizes OSB-3, -4 and -5. See Figures 6 and 7, page 8, for recommended piping of OSB-6 boilers. These piping recommendations apply only to connections to parallel-flow one-pipe and two-pipe systems. For counterflow systems, connect boiler supply and return to counterflow system header as shown in Figure 3, below. Table 4, below, gives recommended pipe sizes.

Table 4 Recommended pipe sizing

Boiler model number	Riser pipe size (Note 1)		Header pipe size "H" (Note 2)	Equalizer pipe size "J"
	A	B		
OSB-3	2 1/2"	--	2 1/2"	1 1/2"
OSB-4	2 1/2"	--	2 1/2"	1 1/2"
OSB-5	2 1/2"	--	3"	1 1/2"
OSB-6	2 1/2"	2 1/2"	4"	1 1/2"

#### Notes:

1. Based on ASHRAE Fundamentals Handbook recommendations, allowing 1/2 oz. pressure drop at 0 psig.
2. Based on ASHRAE Fundamentals Handbook recommendations, allowing 2 oz. pressure drop per 100 feet of pipe at 3.5 psig. Maintain minimum 24" height from waterline to bottom of header. Note Figure 3, showing the special connection required to a counterflow system.

### Connecting to counterflow piping

Apply the recommended piping in Figures 4 through 7 only when connecting to a parallel-flow system. When connecting to a counterflow system, the boiler steam supply must connect into the top of the counterflow system header, as shown in Figure 3, below.

Figure 3 Connection to counterflow steam piping only (for parallel flow systems, see page 8)

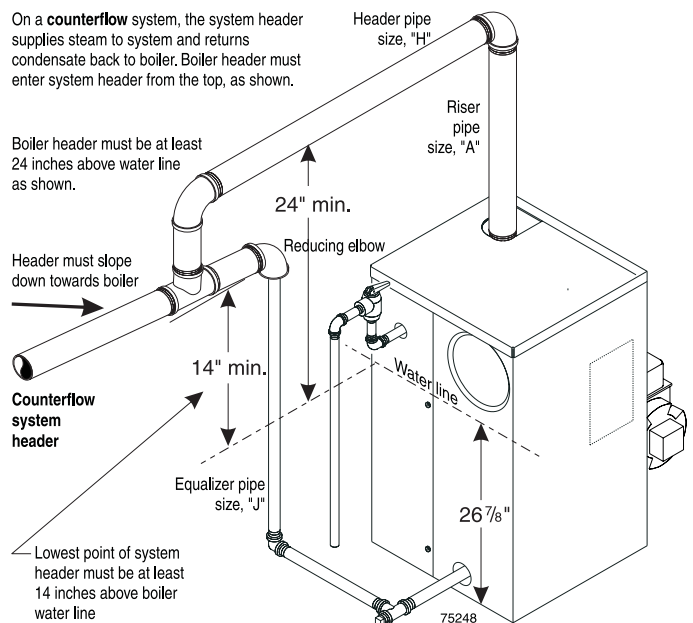

## 4 Connect steam piping continued

**Figure 4** Recommended piping, OSB-3, -4 and -5, piping for parallel-flow systems only

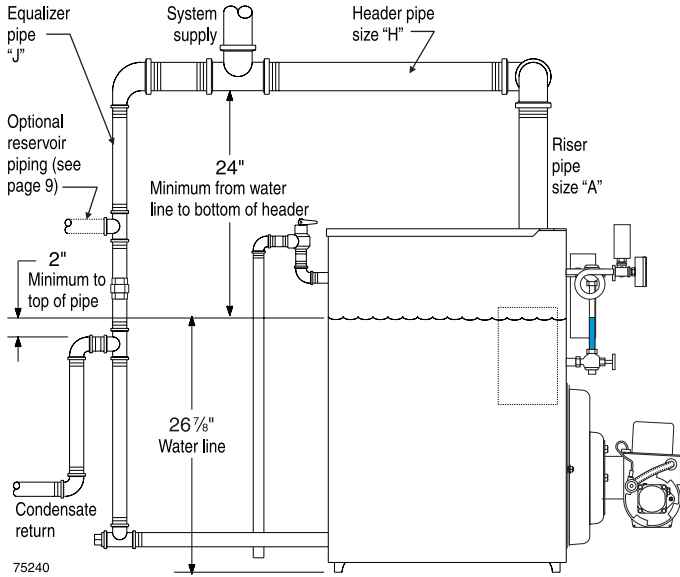

**Figure 5** Recommended piping, OSB-3, -4 and -5, piping for parallel-flow systems only

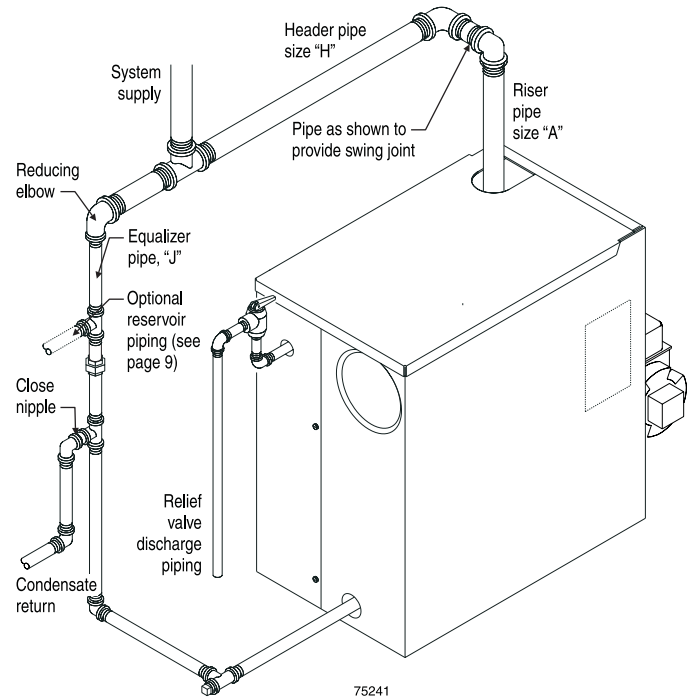

**Figure 6** Recommended piping, OSB-6, piping for parallel-flow systems only

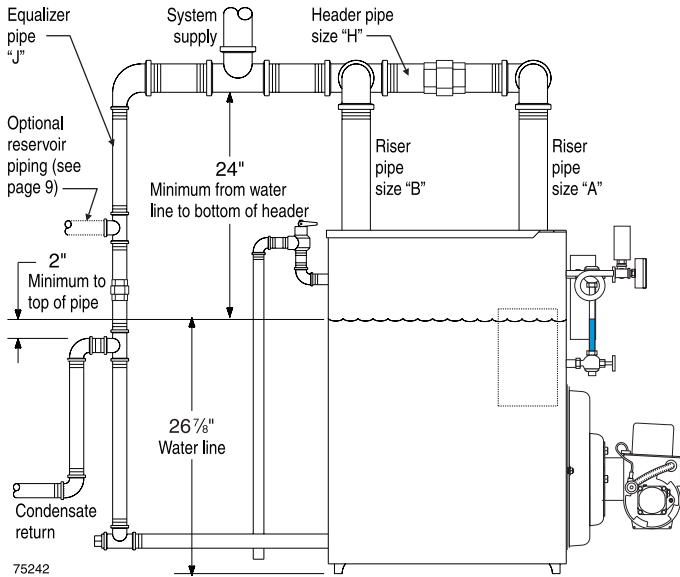

**Figure 7** Recommended piping, OSB-6, piping for parallel-flow systems only

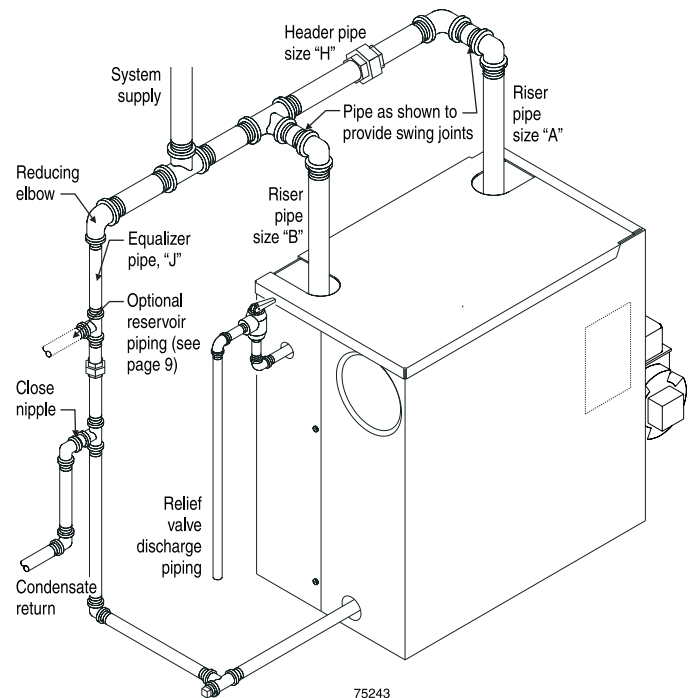

**NOTICE**

Float-type low water cutoff — If field installing a float-type low water cutoff, it must be piped only to the gauge glass tapplings. See Figure 19 on page 26. The tapplings are spaced 9 7/8" on center. Use only float-type low water cutoffs with quick-connect hookups that will provide a low water cutoff point no higher than 2" above the center of the bottom tapping.



## 4 Connect steam piping continued

### Condensate return

Modern steam boilers are designed to steam for less time than older, larger boilers. When replacing an older steam boiler the system condensate return time may be longer than the steaming time. This could cause the following problems:

1. Boilers fitted with an automatic water feed could overflow.
2. Units fitted with only a low water cutoff would shut down and cycle while waiting for condensate to return.

Following is a simple method for determining whether or not a reservoir pipe is required to lengthen steaming time for a residential installation:

1. Disconnect condensate return line at existing boiler.
2. Heat boiler and allow to steam for 10 minutes. Turn off boiler.
3. Measure length of time from when boiler started to steam to when condensate begins to return through condensate line.
4. Measure length of time from when condensate begins to return to when it stops returning. Divide this time by 2.
5. Add time measured in step 3 to time calculated in step 4. This sum is the average time required for condensate to return to the boiler.
6. If this total time is 10 minutes or less, no reservoir pipe is needed.

If total time for condensate to return to boiler (from step 5) is more than 10 minutes, a reservoir pipe (or boiler feed system) is recommended. See Table 5, this page, for suggested reservoir pipe size. Install as shown in Figures 8 and 9, below.

For larger systems (as noted in Table 5), use a boiler feed system with a condensate tank and feed pump. You will have to install a low water cutoff/pump control on the boiler to operate the pump. See "Low water cutoffs" on page 20 and Figure 19 on page 26. Use Table 6 to size boiler feed systems. (The use of a combination condensate tank and float-controlled condensate return pump is not recommended. These devices do not supply water to the boiler on demand from the boiler, and cannot compensate for long condensate return times.)

For most residential installations a reservoir pipe may be all that is necessary to ensure proper operation.

**Figure 8** Recommended piping for parallel-flow systems with optional reservoir pipe

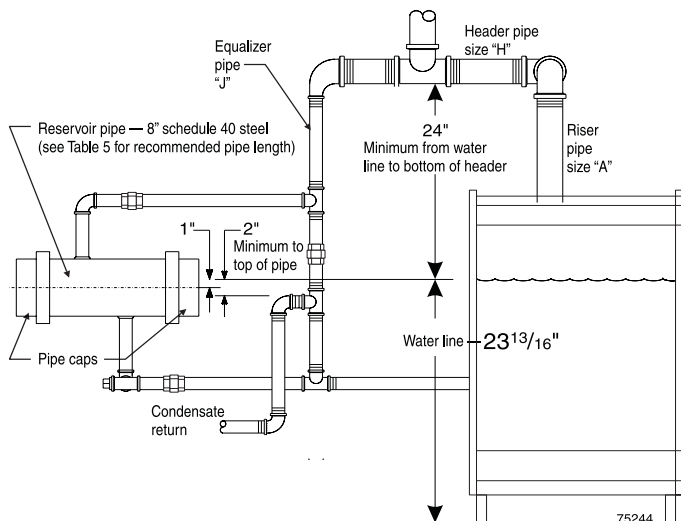

**Table 5** Reservoir pipe sizing

Boiler model number	Boiler gross output	Time from initial steaming to average condensate return (boiler steaming capacity based on 970 Btu per pound of steam)					
		15 minutes		20 minutes		30 minutes	
		gallons	pipe length (feet)	gallons	pipe length (feet)	gallons	pipe length (feet)
OSB-3-100	100	1	1	2	2	Use boiler feed system	
OSB-4-110	110	1¼	1¼	2½	2¼		
OSB-4-125	125	1¼	1¼	2½	2¼		
OSB-5-135	135	1½	1½	3	2½		
OSB-5-150	150	1½	1½	3	2½		
OSB-6-175	175	1¾	1¾	Use boiler feed system			
OSB-6-200	200	2	2				

Designed full capacity steaming time of modern boilers is 10 minutes.

**Table 6** Boiler feed system sizing

Boiler model number	I=B=R gross output (pounds steam per hour)	Condensate (gallons per hour)	Minimum condensate receiver capacity gallons for boiler steaming times (minutes) of: (note 1)				Suggested feed pump capacity (GPM @ 15 PSI) (note 2)
			15 min.	30 min.	45 min.	60 min.	
OSB-3-100	120	14	4	9	13	17	0.5
OSB-4-110	133	16	5	10	14	19	0.5
OSB-4-125	149	18	5	11	16	21	0.6
OSB-5-135	162	19	6	12	18	23	0.6
OSB-5-150	180	22	6	13	19	26	0.7
OSB-6-175	210	25	8	15	23	30	0.8
OSB-6-200	239	29	9	17	26	34	1.0

Notes:  
 1. Maximum time to when condensate returns to boiler.  
 2. If pump exceeds capacity shown, pump can be throttled with globe or ball valve.

**Figure 9** Recommended piping for parallel-flow systems with optional reservoir pipe

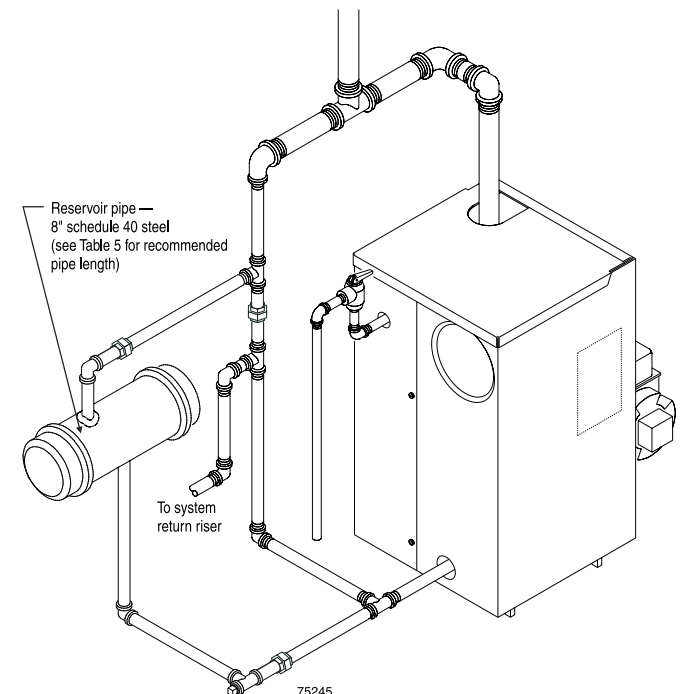

## 5 Connect tankless heater piping, if used

**DANGER Hot water can scald!**

- Consumer Product Safety Commission and some states recommend domestic hot water temperature of 130 °F or less.
- When installing an automatic mixing valve, selection and installation must comply with valve manufacturer’s recommendations and instructions.
- Water heated to a temperature suitable for clothes washing, dish washing and other sanitizing needs will scald and cause injury.
- Children and elderly, infirm or physically handicapped persons are more likely to be injured by hot water. Never leave them unattended in or near a bathtub, shower or sink. Never allow small children to use a hot water faucet or draw their own bath. If anyone using hot water in the building fits this description, or if state laws or local codes require certain water temperatures at hot water faucets, take special precautions:
- Install automatic mixing valve set according to those standards.
- Use lowest practical temperature setting.
- Check water temperature immediately after first heating cycle and after any adjustment.

**WARNING**

Studies have indicated that dangerous bacteria can form in potable water distribution systems if certain minimum water temperatures are not maintained. Contact local health department for more information.

### Pipe tankless heater

1. Size piping no smaller than tankless heater inlet and outlet.
2. Following controls (furnished by others) must be installed:
  - a. Automatic mixing valve. See Figure 10. (Read **DANGER** statement at left.)
  - b. Flow regulating valve (see Figure 10). Size according to intermittent draw of tankless heater. See Table 7. Follow valve manufacturer’s instructions to install.
3. Additional anti-scald devices may be installed at each hot water faucet, bath and shower outlet.
4. In hard water areas, soften cold domestic supply water to heaters to prevent lime buildup.

**Figure 10** Piping connections to tankless heater, typical

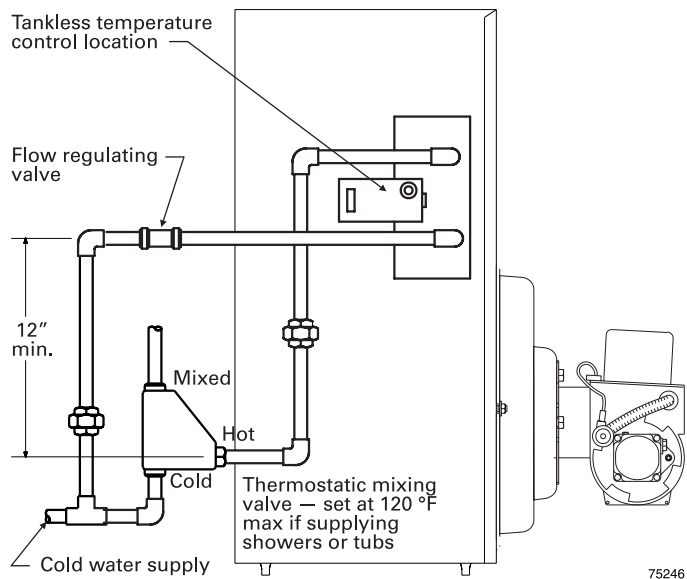

**Table 7** Tankless heater ratings

Boiler model number (Note 1)	Heater number	Intermittent draw ratings (GPM) (Note 2)	Inlet and outlet tapping sizes
OSB-3	35-S-29	3.25	3/4"
OSB-4	35-S-29	3.50	3/4"
OSB-5	35-S-29	3.75	3/4"
OSB-6	35-S-29	4.00	3/4"

Notes:

1. To avoid supplying steam to system during summer tankless operation, raise water level to one inch above normal water line.
2. Gallons of water per minute heated from 40°F to 140°F with 200°F boiler water temperature. Tested in accordance with I=W=H testing and Rating Standard for Indirect Tankless Water Heaters Tested with Boilers.

**NOTICE**

These single wall heat exchangers comply with National Standard Plumbing Code provided that:

- Boiler water (including additives) is practically nontoxic, having toxicity rating or class of 1, as listed in Clinical Toxicology of Commercial Products.
- Boiler water pressure is limited to maximum 30 psig by approved water relief valve.

**NOTICE**

Tankless heater ratings are based on 200°F boiler water temperature. To get rated output, set tankless heater control to 200°F. Control can be adjusted to meet system hot water requirements.

## 6 Connect wiring

**WARNING** Electric shock hazard. Can cause severe personal injury or death if power source, including service switch on boiler, is not disconnected before installing or servicing.

### Installations must follow these codes:

- National Electrical Code, ANSI/NFPA 70, latest edition and any additional national, state or local codes.
- Wiring must be N.E.C. Class 1. If original wire as supplied with boiler must be replaced, type 105 °C wire or equivalent must be used. Supply wiring to boiler and additional control wiring must be 14 gauge or heavier.
- Provide electrical ground at boiler as required by codes.

### Thermostat wiring

- Install thermostat on inside wall away from influences of drafts, hot or cold water pipes, lighting fixtures, television, sun rays or fireplaces.
- Follow instructions with thermostat. If it has a heat anticipator, set heat anticipator in thermostat to match power requirements of equipment connected to it. Boiler wiring diagrams give setting for standard equipment.

### Burner wiring

- Burner harness incorporates a disconnect plug, providing a convenient way to disconnect wiring when burner mounting door is opened. See Figure 11.

### Wiring entrance

- The probe low water cutoff enclosure houses electrical connections for all boiler components.
- Boilers have harnesses furnished. See Figure 12, page 12, (OSB boilers with 801 low water cutoffs) or Figure 13, page 13, (OSB boilers with 450 low water cutoffs) for factory and field wiring information.
- All field-installed high voltage wiring must be sheathed in metal conduit.
- Connect incoming line voltage wires as shown in Figure 12 or Figure 13, page 12. Field-install equipment ground wire to green wire with wire nut.
- Some local codes may require an emergency shut-off switch installed at a location away from boiler. Follow local codes.

**Figure 11** Electrical components and harnesses

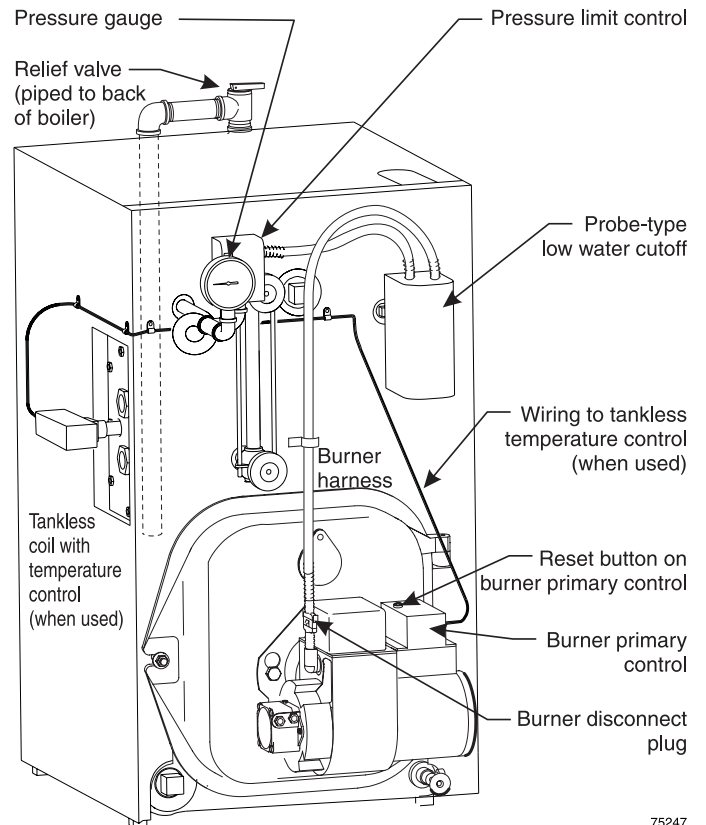

75247

## 6 Connect wiring continued

Figure 12 Wiring diagram — OSB boilers with 801 low water cutoffs

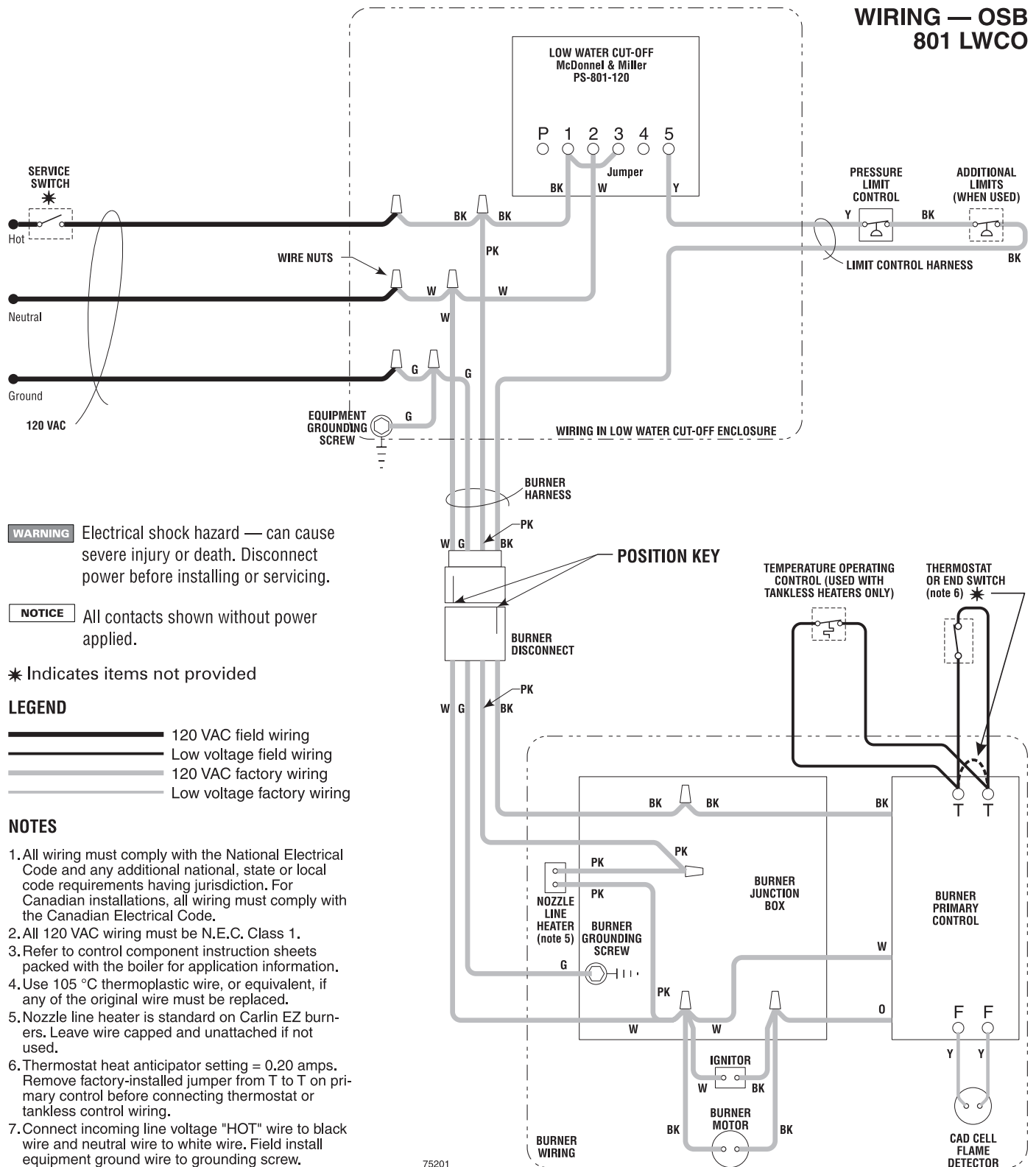

## 6 Connect wiring continued

Figure 13 Wiring diagram — OSB boilers with 450 low water cutoffs

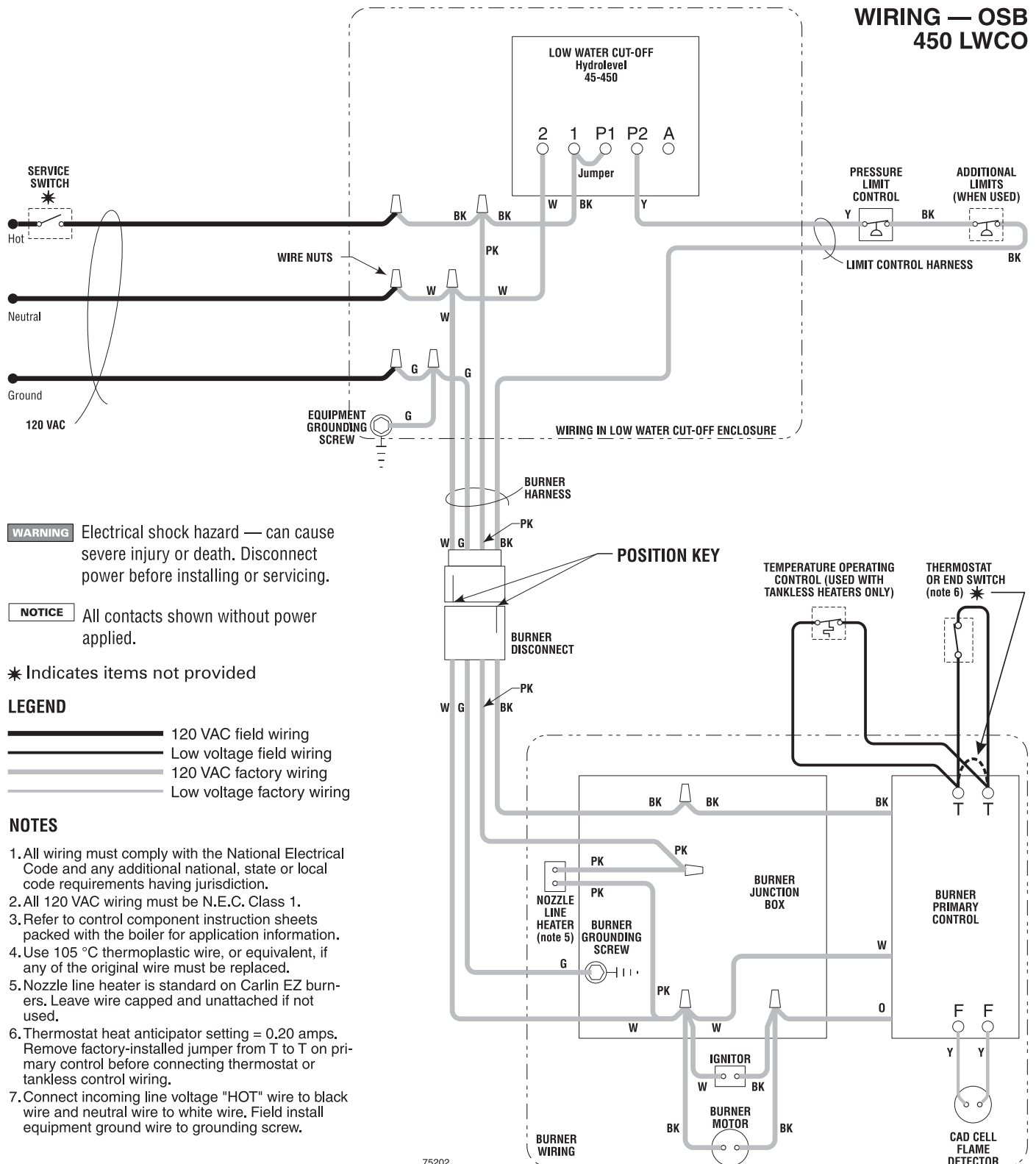

## 7 Connect oil piping

### General oil piping requirements

- Location and installation of oil tanks, oil piping and burners must follow:
  - NFPA 31, Standard for the Installation of Oil-Burning Equipment.
  - Local codes and regulations.
  - Information provided with burner and fuel pump.
- If any part of fuel oil tank is above level of burner, an anti-siphon device must be used to prevent flow of oil in case of oil line break.
- Support oil lines as required by codes.
- Make tank connections with swing joints or copper tubing to prevent breaking in case the tank settles. Make swing joints so they will tighten as tank settles. Non-hardening pipe joint compounds should be used on all threads.

**WARNING**

Do not use Teflon tape as an oil pipe sealant. It can cause valves to fail, creating hazards. Do not use compression fittings, only flare fittings. Failure to comply could result in severe personal injury, death or substantial property damage from oil leakage and/or fire hazard.

- Underground pipe must be run in a casing to prevent oil leaking into ground or under floor. Check local codes for information.

### Oil piping connection at burner

- See Figure 14 for typical oil connection at burner, allowing burner mounting door to swing open completely for servicing.
- Connect oil line to burner using flare fitting (Figure 14).
- See local codes for appropriate arrangement and piping of filter, control valves, etc. connecting to oil tank.
- Refer to burner manual for oil system requirements. Verify that suction lift does not exceed stated limit. Where lift exceeds limit for a one-pipe system, use a two-pipe system as directed in burner manual.

**Figure 14** Oil piping connection to burner, typical

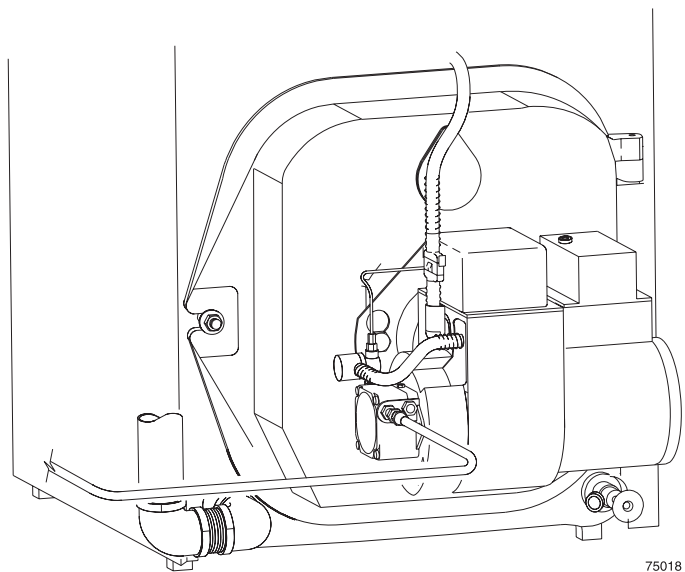

75018



## 8 Start-up

**DANGER** Follow information below to prevent severe personal injury, death or substantial property damage:

- Do not use gasoline crankcase drainings or any oil containing gasoline. See burner manual for proper fuel oil.
- Do not attempt to start burner when excess oil has accumulated, when unit is full of vapor or when combustion chamber is very hot.
- Do not start burner unless collector hood, breeching and burner mounting door are secured in place.
- Never burn garbage or paper in the boiler.
- Never leave combustible material around it.

### Fill the system

1. Do not fill until boiler is ready to be fired (except for leak tests).
2. Fill to normal water line (center of gauge glass), as indicated on jacket front panel.
3. Boiler water pH 7.0 to 8.5 is recommended.

**NOTICE** Failure to maintain recommended pH level can cause section failure and leaks.

4. Follow “Skim steam boiler” to ensure proper operation.

### Tips for steam systems

- Check boiler and system piping for leaks. Continual makeup water will reduce boiler life. Minerals can build up in sections, reducing heat transfer and causing cast iron to overheat, resulting in section failure.

**CAUTION** Failure to maintain recommended pH and repair leaks can cause section iron corrosion, leading to section failure and leaks. Do not use petroleum-based sealing or stop-leak compounds in boiler system. Damage to system components can result.

- For pH conditions outside 7.0 to 8.5 range or unusually hard water areas (above 7 grains hardness), consult local water treatment company.

### Skim steam boiler:

**NOTICE** Steam boilers must be cleaned to remove any impurities. Failure to properly clean can result in violent water level fluctuations, water passing into steam mains, or high maintenance costs on strainers, traps or vents. Skim boiler only. Do not clean old piping or leaks can occur.

**CAUTION** Do not use petroleum-based compounds in boiler system. Damage to system components can result, causing property damage.

1. Provide 1 ½" skim piping from skim tapping to floor drain. Add a tee in piping to observe skim water level. Raise waterline to midpoint of skim tapping (see page 26 for location).
2. Fire burner to maintain water temperature below steaming temperature during skimming process.
3. Feed in water to maintain water level. Cycle burner to prevent rise in steam pressure. Continue skimming until discharge is clear.
4. While boiler is warm, but not hot, drain boiler through drain valve.
5. Remove skim piping. Close drain valve. Fill with fresh water to normal waterline. Start burner and steam for 15 minutes to remove dissolved gases. Stop burner.
6. Check traps and air vents for proper operation.
7. Process may need to be repeated after several weeks of operation.

### Place in operation

1. Verify boiler is filled with water to normal waterline, as indicated on jacket front panel.
2. Open burner mounting door and verify rear target wall, floor and burner door insulations are in proper position and condition.
3. Verify burner mounting door is closed tightly and burner wiring harness is connected securely.
4. Factory burner adjustment and settings may not be suitable for specific job conditions. Refer to burner manual for burner start-up, adjustment and checkout procedures.
5. Refer to burner manual for start-up. Allow boiler to heat to design temperature. Then adjust burner for correct combustion, using combustion test equipment. Adjust burner for:  
Draft: –0.01 to –0.02 inches water column draft in boiler combustion chamber.  
CO<sub>2</sub>: between 11% and 12%, with 0 smoke.

**WARNING** Make final burner adjustments using combustion test equipment to assure proper operation. Do not fire boiler without water. Sections will overheat, damaging boiler and resulting in substantial property damage.

6. Check boiler and system piping for leaks. See “Tips for steam systems” on this page.
7. Inspect breeching and venting for proper operation.

**NOTICE** For additional information, refer to instructions packed with boiler or burner:

- Burner Manual
- Component literature

## 9 Checkout procedure

### Check off steps as completed

- 1. Boiler properly filled with water?
  - 2. Boiler piping check for leaks (including tankless heater, if used)?
  - 3. System vents and/or traps operating properly?
  - 4. Boiler properly skimmed?
  - 5. Air purged from oil piping? Piping checked for leaks? Burner door closed, sealed and nut tight? Burner harness securely plugged in?
- WARNING** Obtain gas-tight seal at burner door to prevent possible flue gas leakage and carbon monoxide emissions, leading to severe personal injury or death.
- 6. Proper draft and burner flame? Final adjustment made with combustion test equipment?
  - 7. Test pressure limit control: While burner is operating, move indicator on limit control below actual boiler steam pressure. Burner should go off. Raise setting on limit control above boiler steam pressure and burner should reignite.
  - 8. Test low water cutoff(s): Follow control manufacturer's instructions for testing procedures. Make sure burner goes off when control responds to low water condition. Burner should re-ignite when proper water level is restored.
  - 9. Test additional field-installed controls: If boiler has additional operating control or other controls, test for operation as outlined by control manufacturer. Burner should be operating and should go off when controls are tested. When controls are restored, burner should reignite.
  - 10. Limit control set to system pressure requirements?
  - 11. Thermostat heat anticipator setting (if available) set properly? Refer to "Connect wiring," page 11.
  - 12. Boiler cycled with thermostat? Raise to highest setting and verify boiler goes through normal start-up cycle. Lower to lowest setting and verify boiler goes off.
  - 13. Observed several operating cycles for proper operation?
  - 14. Set room thermostat(s) to desired room temperature?
  - 15. Completed "Installation and service certificate" below?
  - 16. Reviewed User's Information Manual with owner or maintenance person and instructed person to keep for future reference?
  - 17. Returned all instructions provided with boiler to its envelope and placed with boiler for future reference?

## 9 Checkout procedure continued

<b>Boiler model</b> _____	<b>Series</b> _____
<b>CP number</b> _____	<b>Date installed</b> _____
<b>Measured Btuh input</b> _____	<input type="checkbox"/> <b>Installation instructions have been followed.</b>
	<input type="checkbox"/> <b>Checkout sequence has been performed.</b>
	<input type="checkbox"/> <b>Above information is certified to be correct.</b>
	<input type="checkbox"/> <b>Information received and left with owner/maintenance person.</b>
<b>Installer</b> _____	_____
(company)	(address) (phone)
	_____
	(installer's signature)

# 10 Service and maintenance

## Annual service and start-up

**WARNING** Follow the “Service and maintenance” procedures given throughout this manual and in component literature shipped with the boiler. Failure to perform the service and maintenance could result in damage to the boiler or system. Failure to follow the directions in this manual and component literature could result in severe personal injury, death or substantial property damage.

**WARNING** The boiler should be inspected and started annually, at the beginning of the heating season, only by a qualified service technician. In addition, the maintenance and care of the boiler designated in the table below, and explained on the following pages must be performed to assure maximum boiler efficiency and reliability. Failure to service and maintain the boiler and system could result in equipment failure.

Annual Service Call Check List (follow in order listed below)		D	D	D	D	D	D	D	D	D	D	Comments
		A	A	A	A	A	A	A	A	A	A	
		T	T	T	T	T	T	T	T	T	T	
		E	E	E	E	E	E	E	E	E	E	
1	Clean boiler flueways. See page 19.											
2	Check that boiler area is free from combustible materials, gasoline and other flammable vapors and liquids.											
3	Check for and remove any obstruction to combustion and ventilation air flow to boiler											
4	Check boiler and piping for leaks and repair if found.											
5	Perform service on low water cutoff, relief valve and gauge glass. See pages 20 and 21.											
6	Check breeching and chimney or vent for obstructions, damage, etc. Repair or replace as necessary.											
7	Make sure boiler is filled to correct water level. See page 20.											
8	Inspect and adjust burner. See burner manual and: - change nozzle. - check ignition electrode settings. - clean blower housing and wheel. - make sure blower wheel turns freely. - oil burner motor if required. - clean air inlet. - clean or change fuel filter and strainer.											
9	Start unit and verify combustion settings with combustion test equipment. See page 21.											
10	Verify operation of all controls on boiler.											

# 10 Service and maintenance continued

## Cleaning boiler flueways

**WARNING** The boiler contains ceramic fiber and fiberglass materials. Use care when handling these materials per instructions on page 28 of this manual. Failure to comply could result in severe personal injury.

**DANGER** Make sure all electrical connections to boiler are turned off and wait until boiler is warm, not hot, before cleaning. Failure to do so will result in severe personal injury, death or substantial property damage.

1. Remove jacket top panel.
2. Remove flue collector hood, saving hardware for reassembly.
3. Shut off oil valves. Arrange drip pans under the areas of oil piping that will be disconnected. Disconnect oil line at burner so that you can swing open the door completely.
4. Line combustion chamber floor with newspaper to catch any soot that will be loosened in the cleaning process.
5. Starting at the top of the boiler, use a wire flue brush to thoroughly clean between all pins at all angles. Be careful not to damage side walls of rear refractory.
6. Move to the bottom of the flueways and clean up between the sections to reach pins left uncleaned in step #5.
7. Once the flueways are cleaned, carefully remove the paper from the floor of the combustion chamber. Fold the paper to capture the refuse, seal in a plastic bag, and dispose.
8. Verify sealing rope around flue area is intact. Visually check condition and position of insulation in combustion chamber floor, and the refractories at the rear of boiler and in the burner mounting door. Replace any parts as necessary.
9. Close burner mounting door and tighten nut securely. Place flue collector hood on top of boiler. Secure with hardware from step #2. Maintain a gas-tight seal to avoid possible flue gas leakage and carbon monoxide emissions, which can lead to severe personal injury or death.
10. Check breeching for sooting and clean if necessary. Install jacket top panel and breeching.
11. Reconnect oil line and all electrical connections.

**Figure 15** Cleaning boiler flueways — Thoroughly clean flueways between all pins at all angles. Start on top of boiler, finish from the bottom.

**WARNING** Wear a NIOSH-certified dust respirator (N95) while cleaning the boiler, per WARNING on page 28. Failure to comply could result in severe personal injury.

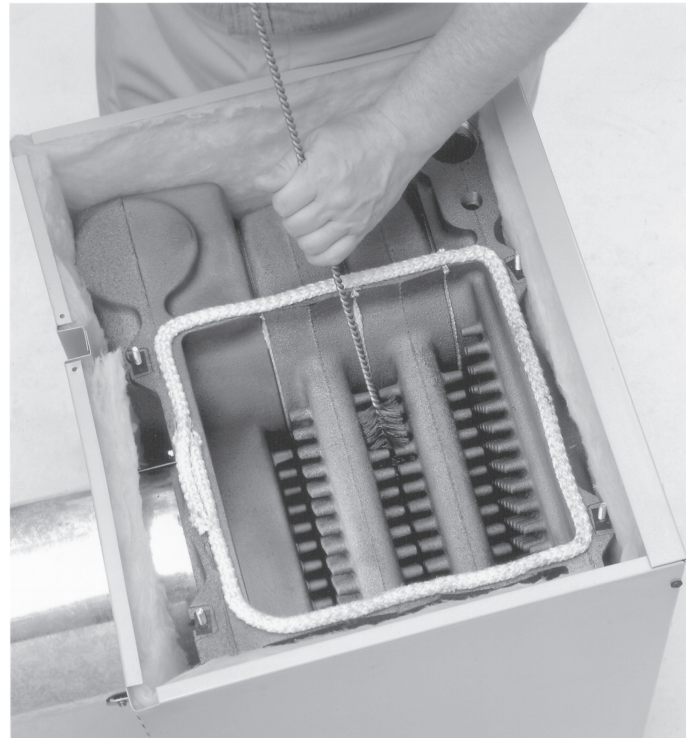

## □ Inspect . . . . .

### Reported problems

Inspect any problems reported by owner and correct before proceeding.

### Boiler area

1. Verify that boiler area is free of any combustible materials, gasoline and other flammable vapors and liquids.
2. Verify that boiler area is free of any of the contaminants listed in Table 2 on page 5 of this manual. If any of these are present in the boiler intake air vicinity, they must be removed. If they cannot be removed, install combustion air piping to the boiler in accordance with national, provincial or local codes.

### Piping

1. Check the boiler interior piping and all system piping for signs of leaks.
2. Repair any leaks before proceeding.

**DANGER** Do not use petroleum-based cleaning or sealing compounds in boiler system. Severe damage to boiler will occur, resulting in substantial property damage.

**WARNING** Eliminate all system or boiler leaks. Continual fresh makeup water will reduce boiler life. Minerals can build up in sections, reducing heat transfer, overheating cast iron, and causing section failure. Leaking water may also cause severe property damage.

# 10 Service and maintenance continued

## ☐ Service . . . . .

### Gauge glass

Normal waterline is halfway up gauge glass. Clean when needed.

1. Close lower gauge cock.
2. Open pet cock.
3. Open lower gauge cock and allow a small amount of water to flush out through open pet cock.
4. Close pet cock.
5. Open lower gauge cock.

**DANGER** Boiler pressure must be low to eliminate potential of severe burns.

**WARNING** If gauge glass breaks, close both gauge cocks. Replace gauge glass. Do not replace with thin glass tubing. Failure to comply could cause severe personal injury, death or substantial property damage.

## ☐ Check/test . . . . .

### Boiler waterline

Normal waterline is halfway up gauge glass.

### Limit controls

1. Inspect and test the boiler limit control. Verify operation by turning control set point below boiler pressure. Boiler should cycle off. Return dial to original setting.

## ☐ Check/test . . . . .

### Low water cutoffs

#### Probe-type low water cutoff (see below)

Clean and test probe-type low water cutoff for proper operation. Remove, inspect and clean the low water cutoff at least annually before testing. Refer to low water cutoff manufacturer's instructions in envelope assembly provided with boiler.

1. Turn off power to boiler and wait 5 minutes.
2. Drain water to bottom of gauge glass.
3. Turn on power.
4. Set thermostat to call for heat. Red neon lamp on lower water cutoff should light.
5. Wait 5 minutes. Boiler should not fire.
6. Refill boiler to correct waterline. Red lamp should go off.
7. Wait 5 minutes. Boiler should fire.
8. Return thermostat to normal setting.

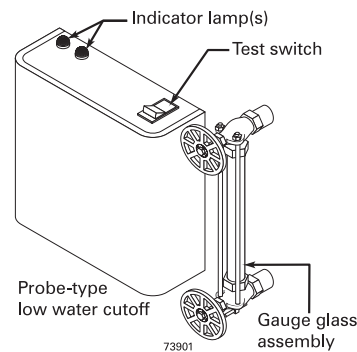

#### Float-type low water cutoff (when provided by others — see below)

Clean and test float-type low water cutoff (when provided by others) to clear float chamber of sediment.

1. Open blowdown valve at bottom control.
2. Drain water into a bucket.

**DANGER** Scald potential. Boiler pressure must be low to avoid the potential of severe burns from steam.

3. Check float-type low water cutoff for proper operation:
  - a. Turn operating control to call for heat.
  - b. Before water gets hot, drain to bottom of gauge glass. Boiler should shut off after water level lowers a few inches.
  - c. Refill boiler to correct waterline. Boiler should come back on.

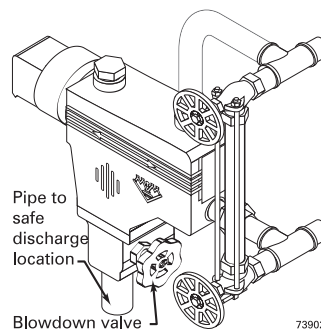



## 10 Service and maintenance continued

### Before operating boiler:

1. Follow steps under “Fill the system”, page 15.
2. Follow steps under “Tips for steam systems”, page 15.
3. Skim the boiler following “Skim steam boiler:”, page 15.

### To place boiler in operation:

**DANGER**

Follow information below to prevent severe personal injury, death or substantial property damage:

- Do not use crankcase drainings or any oil containing gasoline. See burner manual for proper fuel oil.
- Do not attempt to start burner when excess oil has accumulated in combustion chamber, when unit is full of vapor, or when combustion chamber is very hot.
- Do not start burner unless collector hood, breeching and burner mounting door are secured in place. Never burn garbage or paper in the boiler.
- Never leave combustible material around boiler.

1. Verify boiler is filled with water to proper level.
2. Open burner door and verify rear target wall, floor and burner door insulations are in proper condition and position.
3. Verify burner mounting door is closed and bolted tightly and burner plug is connected.
4. Refer to burner manual for burner start-up, adjustment and checkout procedures. Factory burner adjustment and settings may not be suitable for specific job conditions.

**WARNING**

Make final burner adjustments using combustion test equipment to assure proper operation. Do not fire boiler without water. Sections will overheat, damaging boiler and resulting in substantial property damage.

5. Check boiler and system piping for leaks.
6. Inspect breeching and venting for proper operation.

### Annual service

#### Boiler relief valve

1. After following the warning directions below, if the relief valve weeps or will not seat properly, replace the relief valve.

**DANGER**

Before testing, make certain discharge pipe is properly connected to valve outlet and arranged to contain and safely dispose of boiler discharge. Wear gloves to protect your hands from hot surfaces. Verify that discharge piping is installed in accordance with this manual and the instructions on the relief valve tag. Failure to comply will expose operator and others to severe personal injury or death.

**WARNING**

Safety relief valves should be reinspected AT LEAST ONCE EVERY THREE YEARS, by a licensed plumbing contractor or authorized inspection agency, to ensure that the product has not been affected by corrosive water conditions and to ensure that the valve and discharge line have not been altered or tampered with illegally. Certain naturally occurring conditions may corrode the valve or its components over time, rendering the valve inoperative. Such conditions are not detectable unless the valve and its components are physically removed and inspected. This inspection must only be conducted by a plumbing contractor or authorized inspection agency — not by the owner. Failure to reinspect the boiler relief valve as directed could result in unsafe pressure buildup, which can result in severe personal injury, death or substantial property damage.

**WARNING**

Check the setting of the boiler limit control. The control should never be set with a pressure above 10 psig. Operating at a higher pressure can cause damage to the boiler relief valve.

**WARNING**

The boiler relief valve must be tested at least monthly during the heating season to verify the valve and discharge piping flow freely. If corrosion and/or deposits are noticed within the valve body, testing must be performed more often. A “try lever test” must also be performed at the end of any non-service period. Follow the instructions below for a “try lever test”:

- With the system at operating pressure, lift and hold the test lever fully open for at least 5 seconds to flush the valve seat free of sediment and debris. Then release lever and permit the valve to snap shut.

### Review with owner

1. Review the User’s Information Manual with the owner.
2. Emphasize the need to perform the maintenance schedule specified in the User’s Information Manual (and in this manual as well).
3. Remind the owner of the need to call in a licensed contractor should the boiler or system exhibit any unusual behavior.
4. Remind the owner to follow the proper shutdown procedure and to schedule an annual start-up at the beginning of the next heating season.

# 11 Replacement parts

Figure 16 Boiler section assembly, refractories, collector hood and burner door assembly

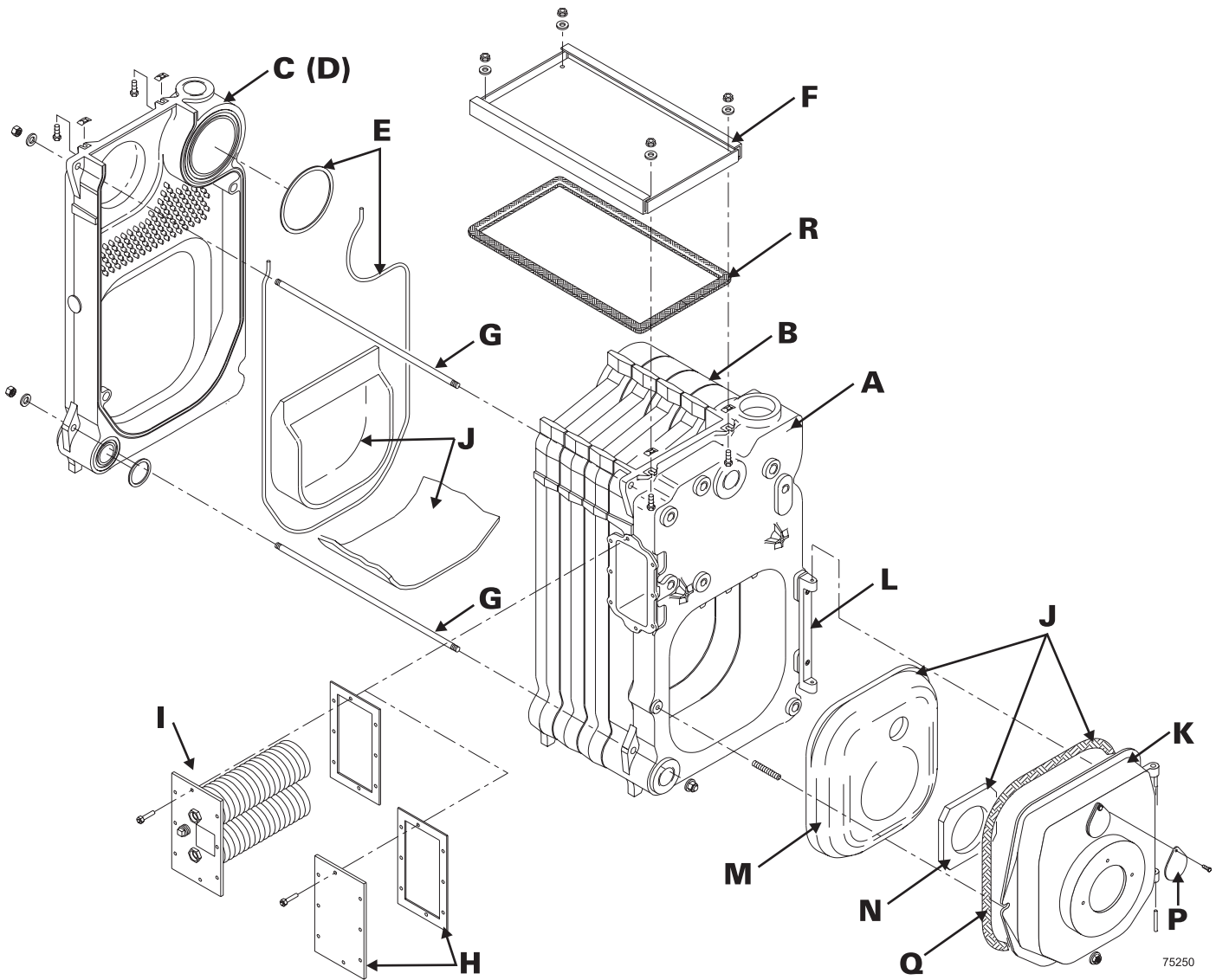

# 11 Replacement parts continued

**Table 8** Parts list for Figure 16

Figure number	Description	Boiler model number	Part number
A	Wide front section, number 7111	All	316-722-009WT
B	Intermediate section, 7115	All	316-722-017WT
C	Back section, 7117 (steam, no top tapping)	OSB-3, -4, -5	316-722-025WT
D	Back section, 7117 (steam, top tapping)	OSB-6	316-722-029WT
E	Section replacement kit, front or back section (for 1 joint, includes seals, rope, adhesive and collector hood hardware)	All	386-700-852WT
	Section replacement kit, intermediate section (for 2 joints, includes seals, rope and adhesive)	All	386-700-851WT
	Section assembly complete	OSB-3	326-700-030WT
		OSB-4	326-700-031WT
		OSB-5	326-700-032WT
		OSB-6	326-700-033WT
F	Collector hood kit (includes rope and hardware for installation)	OSB-3	386-700-837WT
		OSB-4	386-700-838WT
		OSB-5	386-700-839WT
		OSB-6	386-700-840WT
G	Tie rod ½ x 12 ¼	OSB-3	560-234-493WT
	Tie rod ½ x 15 ¾	OSB-4	560-234-532WT
	Tie rod ½ x 18 ½	OSB-5	560-234-475WT
	Tie rod ½ x 21 ⅝	OSB-6	560-234-536WT
H	Heater cover plate carton (cover plate, gasket, studs and nuts)	All	560-700-360WT
I	Tankless heater carton, 35-S-29 (heater, gasket, studs and nuts)	All	560-700-350WT
J	Combustion chamber kit (rear and front refractory, door refractory blanket and water glass)	All	386-700-836WT
	Burner mounting door assembly (door, observation port, rope, insulation and pins)	All	343-500-546WT
K	Burner mounting door, 7171	All	330-054-305WT
L	Door hinge, 7054	All	330-054-300WT
M	Door refractory	All	592-400-028WT
N	Door refractory blanket	All	591-222-115WT
P	Observation port shutter	All	460-039-867WT
Q	Door seal rope 5'	All	590-735-105WT
R	¾" glass rope for collector hood (7' for largest size hood)	All	590-735-109WT
	Flue brush, 123D	All	591-706-214WT

# 11 Replacement parts continued

Figure 17 Jacket parts and replacement instructions

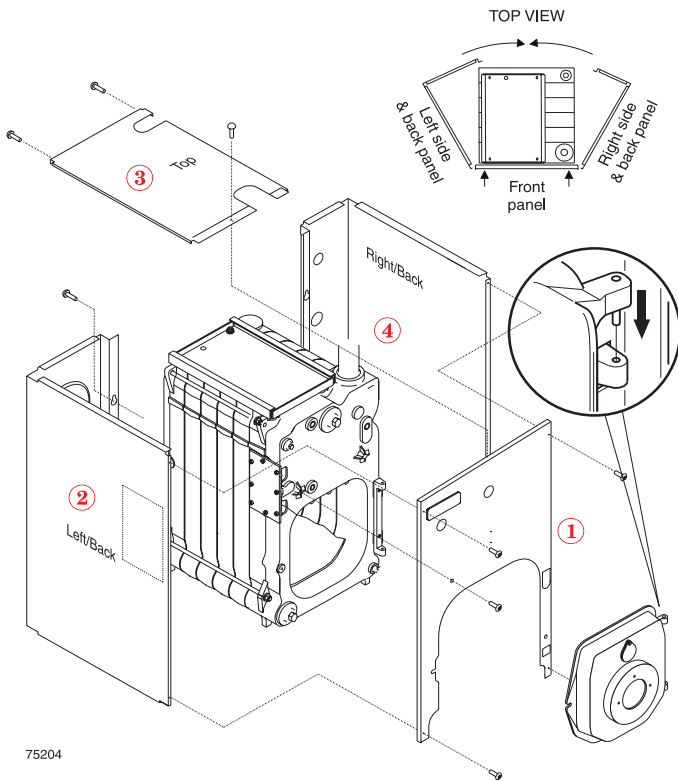

75204

Item number	Description	Boiler model number	Part number
1	Jacket panel, front	All	426-722-005WT
2	Jacket panel, left side and back	OSB-3 OSB-4 OSB-5 OSB-6	426-722-027WT 426-722-029WT 426-722-031WT 426-722-033WT
3	Jacket panel, top	OSB-3 OSB-4 OSB-5 OSB-6	426-722-015WT 426-722-017WT 426-722-019WT 426-722-021WT
4	Jacket panel, right side and back	OSB-3 OSB-4 OSB-5 OSB-6	426-722-037WT 426-722-039WT 426-722-041WT 426-722-043WT
	Jacket hardware kit	All	386-700-845WT

**WARNING** The boiler contains ceramic fiber and fiberglass materials. Use care when handling these materials per instructions on page 28 of this manual. Failure to comply could result in severe personal injury.

**Before installing jacket:**

Before installing jacket:

- Remove the following knockouts:
  - Steam return knockout (lower left back panel).
  - Relief valve knockout (upper right back panel).
  - Rectangular tankless heater and tankless control knockouts (left side panel), if tankless heater is to be installed.
  - Remaining knockout (right back panel) if indirect-fired water heater is to be installed.
- Make sure all unused tappings are plugged.
- These parts may be on boiler:
  - Supply piping
  - Drain valve
  - Tankless heater
- These parts must be off boiler:
  - Breeching connection
  - Steam or water trim parts and piping
  - Tankless heater control and piping
  - Return piping
  - Steam or water relief valve and piping
- Remove burner mounting door by removing locking nut and lifting door off hinge. Do not remove hinge.

**To install jacket:**

- Install jacket front panel to front section, making sure burner door hinge lugs extend through holes in lower jacket leg. Secure with two 3/8" x 1/2" black machine screws.
- Right and left side pieces are shipped as straight pieces. Before installing, bend about 90° at perforation as shown, to form sides and back panels.
  - Secure side panels to front panel with four sheet metal screws.
  - To secure back panels, using two 1/4" x 1/2" self-tapping screws:
    - Start upper screw in boiler section. Do not tighten.
    - Slip keyhole opening in back panels behind screw.
    - Install lower screw and tighten both screws.
  - Install top panel and secure with two sheet metal screws.
- Reinstall burner mounting door and secure locking nut on stud, making sure door is secured gas-tight.

**WARNING** Gas-tight seal must be obtained at door to prevent possible flue gas leakage and carbon monoxide emissions, leading to severe personal injury or death.

# 11 Replacement parts continued

Figure 18 Trim and controls

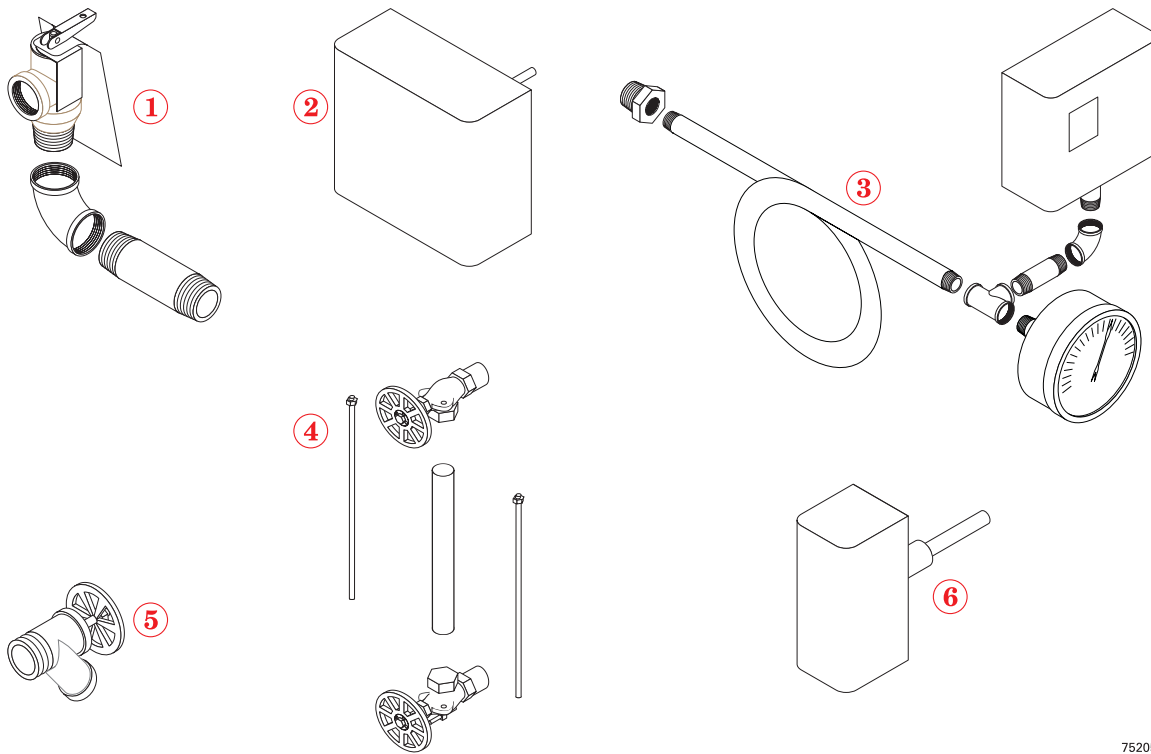

75205

Item number	Description	Manufacturer	Manufacturer's part number	Part number
1	Pressure relief valve, ASME, 30 PSIG, 3/4" npt (Fittings shown are included — Ell 3/4" npt, Nipple 3/4" npt)	Conbraco Watts	13-501-08 315	511-548-023WT 511-548-023WT
2	Low water cutoff, probe-type	McDonnell & Miller Hydrolevel	PS-801-120 45-450	511-114-507WT 511-114-507WT
3	Limit control/gauge assembly, includes: High limit pressure control Gauge, pressure, 2 1/2" Siphon, 1/4" npt, 180° brass Nipple, close 1/4" npt Tee, 1/4" npt Elbow, 1/4" npt	Honeywell Ametek	PA404A1009 P505K	510-312-135WT 510-218-045WT 560-640-698WT 561-326-245WT 561-541-200WT 561-115-335WT
4	Gauge glass assembly, includes: Gauge glass Gauge glass guards, 10.62" Gauge cock set, brass	Conbraco	21-205-03-W	591-419-194WT 563-334-597WT 510-218-135WT
5	Drain valve, 3/4"	Conbraco Hammond Matco-Norca Watts	31-606-01 710 205F04 BD-2C	511-210-423WT 511-246-392WT 511-246-392WT 511-246-392WT
6	Tankless temperature control (optional) 10°F differential; with well	Honeywell	11C18-2	510-312-209WT
not shown	Burner harness			591-391-913WT
not shown	Pressure control harness			591-391-912WT
not shown	Burner plug			643-900-020WT
not shown	Balanced draft control (barometric)	Effikal	ESOC-7	510-512-267WT

# 12 Dimensions

**Figure 19** Dimensional drawing — ALL DIMENSIONS IN INCHES

- ① Supply piping one (note 1)
- ② Supply piping two, OSB-6 only (note 1)
- ③ Return piping (note 1)
- ④ Relief valve, 3/4" NPT
- ⑤ Vent connection — 7" diameter
- ⑥ Burner opening — 4 3/8" diameter
- ⑦ Oil burner
- ⑧ Drain valve
- ⑨ Tankless coil & combination limit (when used)
- ⑩ Pressure gauge
- ⑪ Pressure limit control
- ⑫ Probe-type low water cutoff

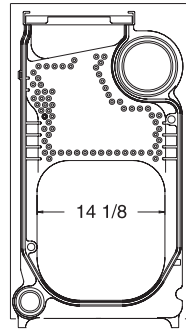

INTERMEDIATE SECTION

ALL DIMENSIONS IN INCHES

**Note 1:** Boiler supply tappings are 2 1/2" NPT. Return tapping is 2" NPT on all boiler sizes. See Table 4, page 7 for recommended system supply and return piping sizes. You must install two supply tappings for sizes OSB-6.

**Note 2:** Float low water cutoff, if used, must be installed in gauge glass tappings. No other location is acceptable.

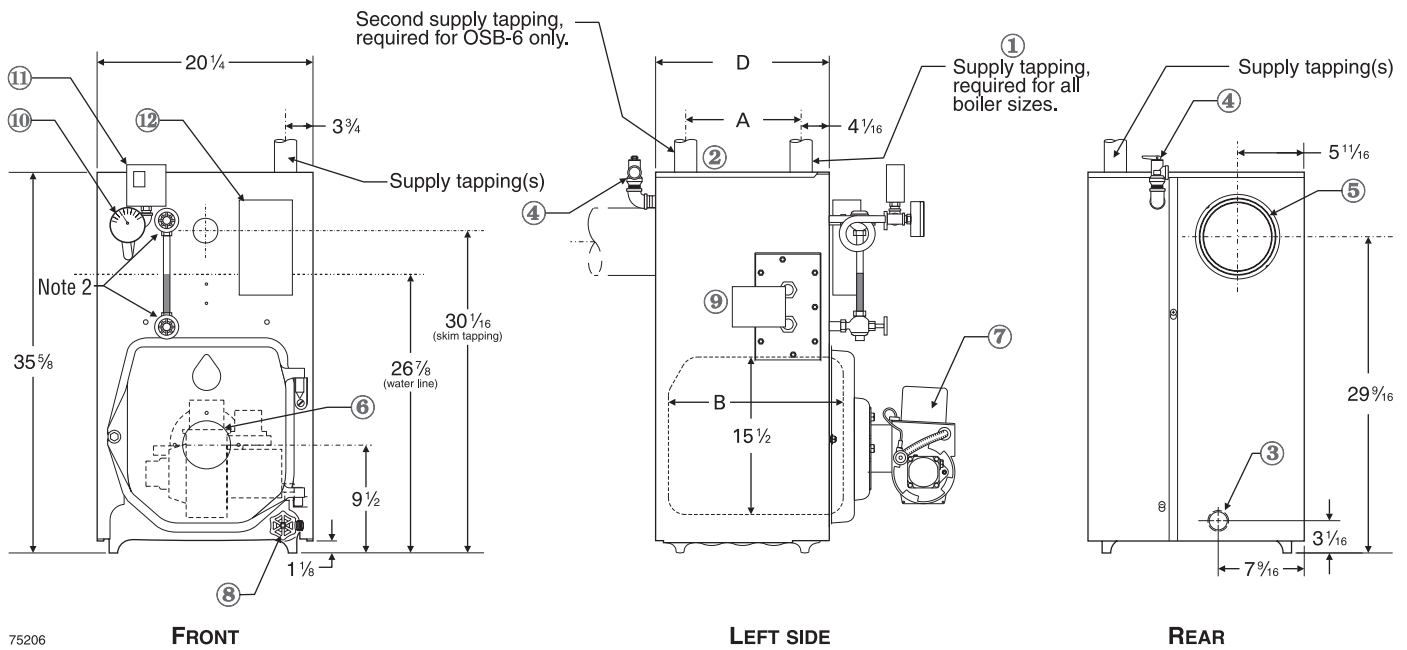

75206

Boiler model number	Supply tapping (inches NPT)	Return tapping (inches NPT)	"A" Supply riser spacing (inches)	"B" Combustion chamber depth (inches)	"D" Jacket depth (inches)
OSB-3	2 1/2	2	--	13 1/2	16 7/8
OSB-4	2 1/2	2	--	16 5/8	20
OSB-5	2 1/2	2	--	17 7/8	22 1/8
OSB-6	2 1/2	2	19	23 1/2	26 1/4



# 13 Ratings



DOE

Boiler model number	I=B=R burner capacity GPH	DOE heating capacity MBH	Net I=B=R ratings MBH		DOE seasonal efficiency % AFUE	Round flue outlet size inches	Minimum I=B=R Chimney			Boiler water content (gallons @ normal waterline)	Draft loss through boiler inches W.C.
			Steam sq. feet	Steam MBH			Rectangle inches	Round inches	Height feet		
	Note 2	Notes 2 & 3	Notes 1 & 4		Note 5	Note 6			Note 7		
OSB-3-100	1.00	116	363	87	82.1	7	8 x 8	6	15	10.7	.000
OSB-4-110	1.10	129	404	97	82.0	7	8 x 8	6	15	12.5	.010
OSB-4-125	1.25	145	454	109	81.7	7	8 x 8	6	15	12.5	.010
OSB-5-135	1.35	158	492	119	81.5	7	8 x 8	7	15	14.2	.010
OSB-5-150	1.50	175	546	131	81.4	7	8 x 8	7	15	14.2	.010
OSB-6-175	1.75	204	638	153	81.1	7	8 x 8	7	15	16.0	.000
OSB-6-200	2.00	232	725	174	81.4	7	8 x 8	7	15	16.0	.015

**Notes**

1. See information at right for model number suffixes.
2. MBH refers to thousands of Btu per hour.
3. Base on 140,000 Btu per gallon.
4. Based on standard test procedures prescribed by the United States Department of Energy.
5. Net I=B=R ratings are based on net installed radiation of sufficient quantity for the requirements of the building and nothing need be added for normal piping and pickup. Ratings are based on a piping and pickup allowance of 1.333. An additional allowance should be made for unusual piping and pickup loads.
6. See page 6 for minimum breeching diameter.
7. Listed draft losses are for factory-shipped settings.

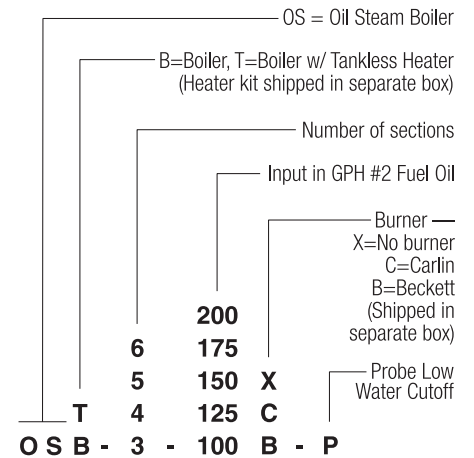

**NOTICE** OSB boilers are designed for installation on combustible flooring. OSB boilers are ASME rated for 50 psig working pressure.

# Handling ceramic fiber and fiberglass materials

## REMOVAL OF COMBUSTION CHAMBER LINING OR BASE PANELS

**WARNING**

The combustion chamber lining or base insulation panels in this product contain ceramic fiber materials. Ceramic fibers can be converted to cristobalite in very high temperature applications. The International Agency for Research on Cancer (IARC) has concluded, "Crystalline silica inhaled in the form of quartz or cristobalite from occupational sources is carcinogenic to humans (Group 1).":

- Avoid breathing dust and contact with skin and eyes.
  - Use NIOSH certified dust respirator (N95). This type of respirator is based on the OSHA requirements for cristobalite at the time this document was written. Other types of respirators may be needed depending on the job site conditions. Current NIOSH recommendations can be found on the NIOSH web site at <http://www.cdc.gov/niosh/homepage.html>. NIOSH approved respirators, manufacturers, and phone numbers are also listed on this web site.
  - Wear long-sleeved, loose fitting clothing, gloves, and eye protection.
- Apply enough water to the combustion chamber lining or base insulation to prevent airborne dust.
- Remove combustion chamber lining or base insulation from the boiler and place it in a plastic bag for disposal.
- Wash potentially contaminated clothes separately from other clothing. Rinse clothes washer thoroughly.

**NIOSH stated First Aid.**

- Eye: Irrigate immediately
- Breathing: Fresh air.

## REMOVAL OF FIBERGLASS WOOL — OR —

### INSTALLATION OF FIBERGLASS WOOL, COMBUSTION CHAMBER LINING OR BASE PANELS:

**WARNING**

This product contains fiberglass jacket insulation and ceramic fiber materials in combustion chamber lining or base panels in gas fired products. Airborne fibers from these materials have been listed by the State of California as a possible cause of cancer through inhalation.

- Avoid breathing dust and contact with skin and eyes.
  - Use NIOSH certified dust respirator (N95). This type of respirator is based on the OSHA requirements for fiberglass wool at the time this document was written. Other types of respirators may be needed depending on the job site conditions. Current NIOSH recommendations can be found on the NIOSH web site at <http://www.cdc.gov/niosh/homepage.html>. NIOSH approved respirators, manufacturers, and phone numbers are also listed on this web site.
  - Wear long-sleeved, loose fitting clothing, gloves, and eye protection.
- Operations such as sawing, blowing, tear out, and spraying may generate airborne fiber concentration requiring additional protection.
- Wash potentially contaminated clothes separately from other clothing. Rinse clothes washer thoroughly.

**NIOSH stated First Aid.**

- Eye: Irrigate immediately
- Breathing: Fresh air.